



Independent Newspapers/Rusty Bradshaw

Grand opening

Maricopa County District 4 Supervisor Max Wilson, left, was on hand to congratulate Sun City on the renovated Fairway Recreation Center, 10600 W. Peoria Ave., Jan. 27 at the grand opening. Later, visitors toured the facility, including this couple viewing the model railroad club room. Jim Wellman, RCSC assistant general manager, announced the estimated final cost for the two-phase construction is \$16.6 million, down from the original pre-construction \$18 million projection.

Fixed-up Fairway draws accolades

DORA AVERY-PAGE

DAILY NEWS-SUN

After months of anticipation, the final phase of Fairway Recreation Center is open.

Jim Wellman, Recreation Centers of Sun City assistant general manager, said he heard many positive comments from members Tuesday as they checked out the new building, including the pool and spa, exercise rooms and walking track.

Friends Edie Chapman and Natalie Hlavna took a walk around the indoor track during their tour Tuesday.

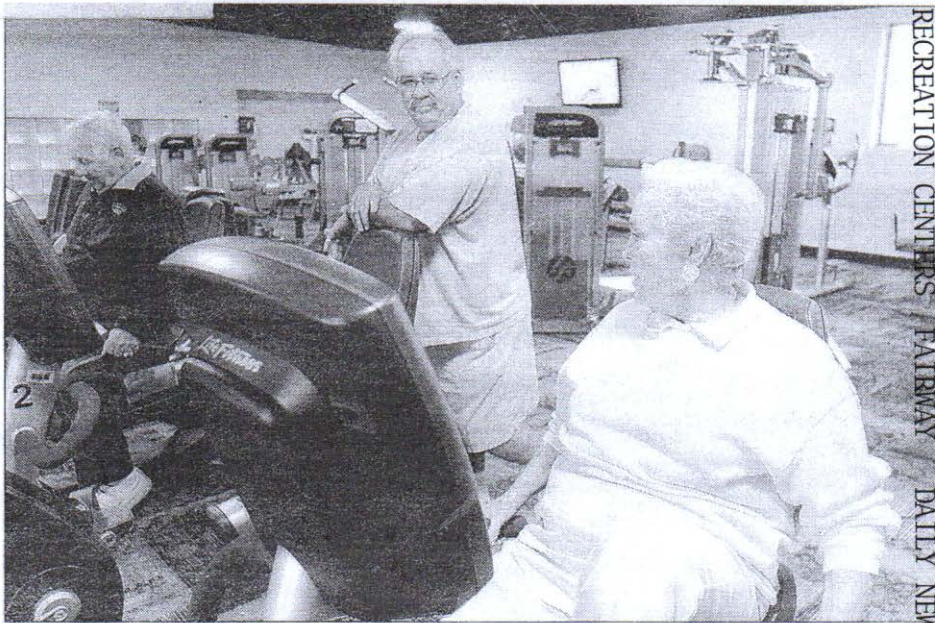

DAVE MARTINEZ/DAILY NEWS-SUN

Bill, Cletus, and Hilda Peck, left to right, check out the stationary bikes during the Fairway Recreation Center's debut Tuesday.

SEE FAIRWAY, A4

FAIRWAY

FROM A1

"I think it's wonderful," Chapman said. "We've been waiting for this for a long time."

Hlavna said she loved the openness of the space and was particularly pleased with the number of treadmills facing the wall-mounted televisions.

"They did a good job," Hlavna said.

"I love the pool, I love the gym, and I love the walking area," Chapman added. "I'll use all three."

After several delays over permit requirements for the pool area, Wellman said RCSC has a tempo-

rary certificate of occupancy for the building. RCSC staff gave tours of the new construction Tuesday before the building opened for use. Wellman said he hopes RCSC will have a full occupancy certificate soon, and RCSC will plan an official open house event in the coming weeks.

There are still several small projects to complete. Wellman said, including the installation of the shade sails over the pool.

Cletus Peck, who visited the facility with his parents Bill and Hilda, said Sun Citizens get a great value for the money with facilities like Fairway.

"The price is right," Peck said, explaining that outside the community, people spend much more

money for gym memberships at facilities that are not as nice as Fairway, or even the other centers.

RCSC facilities attendant Jean Crawford didn't even know that she would be working at Fairway on Tuesday until Monday night, and she was so excited, she said she barely slept.

"There's something here, I'm telling you, for everyone," Crawford said. "What could be better for Sun City than an inside walking track, rather than driving to the mall?"

While Fairway can't compare to their regular center at Mountain View, friends Melva Hemmer and Ann-Marie Tennessen still praised the new building.

"It's very pretty. I like it," Tennessen said.

FAIRWAY IS COMING DOWN



Independent Newspapers/Rusty Bradshaw
Frank Hogan, left, and Lyle DeRose look over the asbestos abatement work at Fairway Recreation Centers, 10600 W. Peoria Ave. The remaining older portions of the center are scheduled to be demolished beginning July 5 to make way for the construction of phase two of the new Fairway Center.



Daily News-Sun



Freedom Communications Newspaper © 2009

Vol. 53 No. 129, 2 Sections 60 Pages

SATURDAY, DEC. 19, AND SUNDAY, DEC. 20, 2009

50¢

FOR BREAKING NEWS, VIDEOS AND TRAFFIC >> www.yourwestvalley.com

Fairway a hit in first look

JEFF DEMPSEY
DAILY NEWS-SUN

A line of visitors extended 50 feet out the door of the Fairway Recreation Center Friday morning, a huge turnout for an open house meant to give residents a look at the new facility.

With guided tours conducted by RCSC staffers, Sun Citians were given a lengthy introduction to what the new facility has to offer.

Many of the clubs have begun to move into their dedicated spaces, although they sit mostly empty. It will be a while before the clubs are completely moved in, but for now, they

SEE FAIRWAY, A5

FAIRWAY

FROM A1

are busy praising the new building. Alan Olson, of the Model Railroad Club, stood in his club's space, a large room that eventually will house an enormous model railroad. With a booth from an adjacent room looking over the space, conditions for model train conducting are perfect.

"We're very happy with our space," Olson said. "The RCSC did very well for us."

Olson and the other club members had sketches and plans laid out for visitors to peruse, giving an idea of what it will become. As for when it will be finished, Olson just smiled.

"Years," he said. "It will take years. And when you're done, you start all over again."

Downstairs in the Ari-

zona Room, the Sun City Stomperz played swinging music while visitors made their way through, taking note of the hardwood floors and the two kitchenettes.

Upstairs, an expansive music room showed promise as a perfect venue for local music lovers.

All in all, there did not seem to be a single person who came away unimpressed.

"I'm going to have to write a letter to (RCSC General Manager) Jan Ek letting her know what a great job they did," said Ed Fumia, a Sun City resident. "We live up near Bell Rec Center now, but we'll drive back down south to visit this place for sure."

Fairway Recreation Center is at 107th and Peoria avenues. For information, visit www.sunaz.com.

Jeff Dempsey may be reached at 623-876-2531 or jdempsey@yourwestvalley.com

Did you guess correctly?



SUBMITTED PHOTO

Phase 1 work continues on Fairway Recreation Center, which we asked readers to identify in Saturday's Daily News-Sun. With sheet rock installed in most of the building, painting began this past month. Several rooms are fully painted. Crews have begun applying the final coat of stucco on the southern exterior, which faces Peoria Avenue. The final coat incorporates the building's exterior color scheme. A new set of construction pictures has been posted online at www.sunaz.com/centers/fairway. Recreation Centers of Sun City officials estimate that Phase 1 of the project will be completed by the end of 2009. At that time, RCSC will help Fairway clubs move into their new rooms and shared spaces. As the clubs move into the new building, RCSC will begin planning Phase 2 of the project, which will include the swimming pool, locker rooms, indoor walking track and fitness area.

Razing Fairway starts in June

STAFF REPORT

The Fairway Recreation Center renovation project will begin June 16 after more than three years of discussions and planning.

"Although we will not be immediately demolishing the Phase 1 buildings at Fairway, we will begin decommissioning these buildings in preparation for demolition in the months ahead," RCSC Assistant General Manager Jim Wellman said Thursday.

Those buildings scheduled for Phase 1 demolition include the Arizona Room, the billiards room, the music room, the auditorium, the library and the pool and spa. All clubs affected by Phase 1 demolition have been notified regarding their temporary locations, and will receive additional notification soon regarding their move date.

The decommissioning process includes asbestos inspections and removal, removing/relocating equipment,

moving of designated clubs to other locations and verifying, disconnecting and relocating utility services to support the club room buildings that will remain on the property until Phase 2 begins.

The Fairway renovation will be paid for out of the RCSC Preservation & Improvement Fund. Fairway, the second-oldest recreation center in Sun City, is scheduled to be rebuilt with new club rooms and newer amenities, including an indoor walking track, walking pool,

swimming pool, spas, expanded Arizona Room and fitness center, using a two-phase construction process. The new facility will offer RCSC cardholders and chartered club members a safer and updated center.

"We know this will be an inconvenience to some RCSC cardholders," said RCSC Board of Directors President Denny Nichols. "But their patience throughout this process will be rewarded with a brand-new facility."

(Arizona Republic)

Fairway Rec Center to be demolished, replaced

By Erin Zlomek

ERIN.ZLOMEK@ARIZONAREPUBLIC.COM

Sun City's Fairway Recreation Center is being demolished and a new center built, with recreation managers citing the decaying facility as "beyond repair."

The facility has an old roof and has experienced equipment failures and false fire alarms due to possible faulty wiring, Sun City Recreation Centers President Don Schordje said.

"In previous years, (management) never invested the money for proper maintenance ... the repairs here are starting to cost more than the center," he said.

The center consists of four separate buildings and a pool area.

The rebuilding will occur in two phases.

In the first phase, developers will demolish the current center's library, large meeting room and pool area, to accommodate a large two-story building. Recreation managers estimate that the first phase will cost anywhere from \$6 million to \$8 million. The goal is to complete Phase One by the end of 2008, Schordje said. Management will shut down portions of the center for that period.

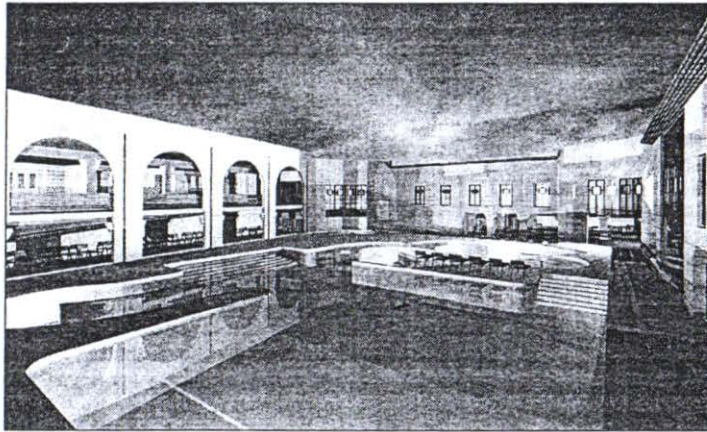

CCBG ARCHITECTS

The new Fairway Recreation Center will include a variety of amenities for Sun City residents.

"(Fairway) will be without a pool for 18 months to two years, but we will find accommodations to keep clubs operating," Schordje said. Management plans to start construction on the first phase in the first half of 2007.

In Phase Two, local clubs and classes will occupy the completed part of the new building while the rest of the structure is finished. Schordje said the cost of Phase Two is contingent on the amount

of time it takes to complete Phase One. Original estimates predicted that the entire renovation would cost about \$15 million.

"We can't predict two to three years down the road how much the construction will cost, and anyone who does that is just taking a stab in the air," he said.

Money from Sun City's capital preservation fee, a \$2,100 one-time fee paid by all new residents, will fund the new center.

"There's a misconception that our annual dues are funding the project, but that is nowhere near the truth," Schordje said.

Sun City residents pay \$360 for dues each year.

"We are paying for this without going to our members and asking for money or raising fees. This is paid for by new people moving into Sun City, and they will be the beneficiaries of this new facility," Schordje said.

Built more than 40 years ago, Fairway is Sun City's second-oldest recreation center. A complete fitness center will replace outdated stationary exercise bicycles. The new complex also will feature an indoor running track, a new outdoor pool and Jacuzzis, new locker rooms, a multipurpose room with full-service kitchen, a library and classrooms to accommodate local clubs.

The classrooms, library, multipurpose room and most electrical work will be part of Phase One. Everything else will be finished in Phase Two.

The indoor walking track was a feature requested by residents. It will go on the center's second floor and overlook the pool area.

"(Residents) that don't go away for summer are not able to walk outdoors due to heat, so it was a high priority to include (an indoor track) in this new facility," Schordje said.

Others are not as taken with new plans, however. Some residents are concerned because a lift for the handicapped is not planned for the new pool. Another concern is that the new pool will not have a deep end to accommodate those with back problems in need of deep-water therapy.

Schordje said the depth of the new pool has not been determined.

At the center on 107th and Peoria Avenues, the exterior paint on each building is fading. Formerly white door signs have yellowed.

"It just looks old," Dorothy Herceg said as she sat on the edge of the pool, talking to a friend and dangling her legs in the water.

"Realtors are starting to not show property properly down in Phase One. ... It's time we put a facility down there that will draw Realtors south of Grand Avenue to draw prospective buyers to Sun City," Schordje said.

Fairway library to cut ribbon

A ribbon cutting ceremony and open house for Fairway Center Library's expanded facilities has been scheduled from 1 to 3 p.m. Saturday.

James Wormley, Recreation Centers board president, will participate in the ceremonies, as will Mrs. Hazel Guider, library board, president Mrs. Phyllis Wood, librarian, and Mrs. Lucretia Spurlock, assistant librarian.

The library, located at Peoria and 107th avenues, will begin regular hours Monday from 10 a.m. to 4 p.m. Monday through Friday.

Wednesday, March 14, 1979 NEWS-SUN

SUN CITY

SUN CITIZEN

Vol. 10 - No. 12 SUN CITY, ARIZONA Ph. 933-3531 Ten Cents 3 SECTIONS Thursday, May 16, 1968

Consolidation Finalized

At a meeting in Town Hall Center offices on May 6, the Articles of Incorporation of Sun City Community Association were officially signed as specified in the Consolidation Agreement executed between Sun City Town Hall Center and Sun City Civic Association, Incorporated on Feb. 8.

The incorporators signing the articles of incorporation and becoming members of the board of directors for the balance of 1968 are Leo J. Wilson, Lin Price, George C. Wilson, James M. Cullum, Esther R. Morris, Bertha M. Cox, Alfred R. Voelker, John W. Prather, Gerald W. McCarty, John R. Mead, Walter F. Schott and Phil T. Ewan.

The articles of incorporation were filed with the Arizona Corporation Commission on May 6 and the advice given that the new corporation was permitted to function immediately. As a result of the incorporation of "The Sun City Community Association", the Sun City Civic Association, Incorporated and Town Hall Center automatically cease to function or exist as Corporations.

The first meeting of the board of directors of the new corporation was held May 9, at Town Hall Center Directors Room. The first order of business was the election of officers to serve for the balance of 1968. The following officers were elected to serve, Lin Price, president; Alfred R. Voelker, vice-president; Esther R. Morris, secretary; John W. Prather, treasurer; and Gerald W. McCarty and Phil T. Ewan, assistant treasurers. The first function of Price as president of the new corporation was to create a new Facilities Committee with Leo J. Wilson as chairman, to follow the construction and remodeling work to be done by the Del E. Webb Company at Sun City Civic Association.

The new committee will work closely with J. Titus who has been given a new contract as the Sun City Community Association Manager. Titus will serve in his new position as he has formerly at Town Hall with added responsibilities and authority. He will report directly to the board of directors. Owen Childress, vice-president and project manager, Del E. Webb Company, Sun City, stated the first phase of the modernization construction at the Town Hall north (Community Center) started May 8. This modernization construction consists of a new shuffle board court with

lights and canopy cover like the new court at Town Hall South; Construct a new building north of the present Arts and Crafts building to house expanded arts and crafts and a ladies' dressing and shower room for the swimming pool.

The present ladies' and men's dressing and shower room will be completely remodeled into one men's dressing and shower room. All air conditioning will be updated to the new refrigerated type installed at Town Hall South. Space will be provided for small business meetings or any sub office that may be required for future operation. A new pool hot water heater will be installed which will make the north pool comparable to the new pool at Town Hall South. Building construction will start in the near future.

With the advent of the Sun City Communication Association the auditoriums, meeting places and pools will be designated as Town Hall South, Mountain View Road and 107th, Town Hall

North, Oakmont and 107th, and Town Hall Center, Peoria and 107th. The general offices of the Sun City Community Association will be at the Town Hall Center. All accounting and general operation will emanate at Town Hall Center under the direction of Titus, manager.

As required under Arizona law and the

Corporation Commission the Articles in Incorporation must be published in a recognized newspaper six times. It has been decided by the board of directors that the by-laws of the new corporation will also be published in order that all Sun Citizens will have an opportunity to become acquainted with their new

corporation. All Sun Citizens automatically become members of the new corporation and renew their membership each year by payment of their membership dues. For the balance of 1968, current holders of 1968 Town Hall cards and current holders of Community Center cards are members of the new corporation and their cards will be honored at all functions, Price said. It is urged that all Sun Citizens try to attend as many functions at all locations as possible. Participation of members in all functions will establish closer relationship for progress toward a greater Sun City, Price said.

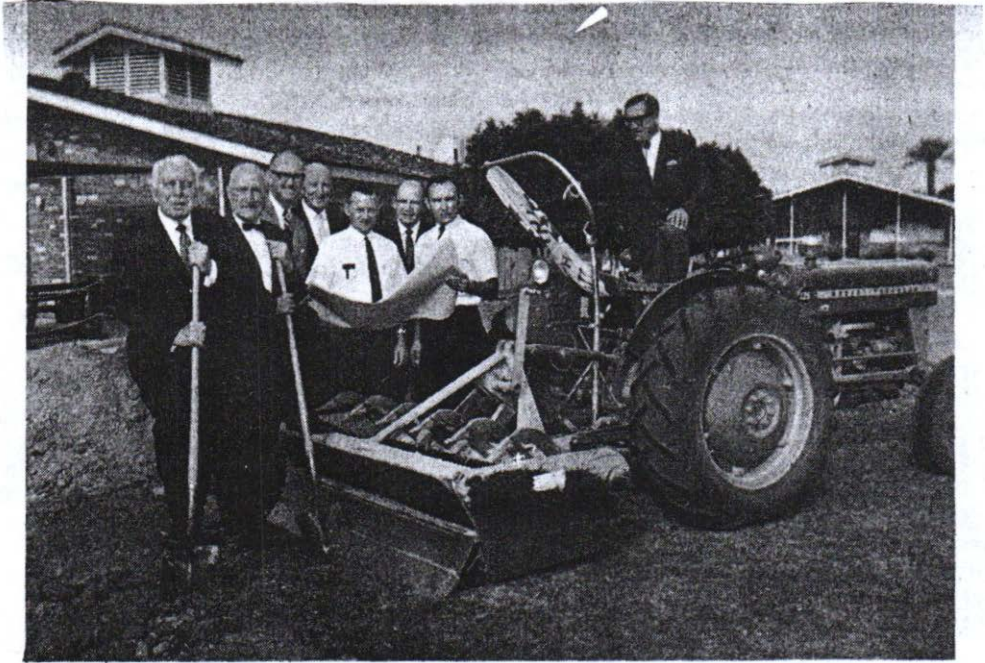

WORK STARTED – Representatives of the Sun City Community Association and Del E. Webb Development Company met last week to break ground for new shuffleboard courts as part of the Community Center

expansion program. From left, they are Lin Price, Leo J. Wilson, Owen Childress, Jim Cullum, Tom Rittenhouse, Walter Schott, Dick Clark and Al Voelker.

SUN CITY

SUN CITIZEN

Vol. 7 - No. 2

Sun City, Arizona

Ph. 933-3531

Ten Cents

Thursday, April 11, 1968

Membership Cards Honored At Both Centers

Effective April 15, membership cards of both Community Center and Town Hall Center will be honored by all activities, according to Leo J. Wilson, president of Community Center, and Lin Price, president of Town Hall

Center. They advised that it will be necessary to display your 1968 membership card at all places and events to gain admittance. This is necessary since it has been learned that too many outsiders are enjoying privileges to which they are not entitled. This reciprocity does not affect clubs until legal and other matters are consummated. It is estimated that complete consolidation will be effective no later than July 1, Wilson and Price stated.

In a joint statement on April 4 by Leo Wilson and Lin Price, it was announced that consolidation papers were started April 1, one month ahead of schedule. To date nearly 1900 signed facility agreements have been received by Community Center.

Plans Made For Merger

At a recent executive meeting of the Town Hall Board and the Community Center Board, its respective presidents, Lin Price and Leo J. Wilson, issued the following joint statements:

"The overwhelming approval March 8 by Town Hall and Community Center property owners for consolidation, and the signing by Community Center property owners of Facilities Agreements far in excess of the number required under the Plan and Agreement for consolidation, has given us the go-ahead to now assemble the many details involved, and complete the legal structure for the now combined corporation to be known as the Sun City Community Association.

Among such considerations engaging our attention are the new Articles of Incorporation, By-Laws, Rules and Regulations, Inventories and Tri-Party Agreement with the Webb Development Corporation restructural improvements and repairs.

Town Hall and Community Center committees are already at work marshalling that data.

Announcements will be made when incorporation is effected. Rallies will be held of all Sun City residents commemorating the occasion. Every effort will be made to consummate consolidation on or before July 1, 1968."

The regular open Board of Electors meeting will be held on Thursday, April 11, at 10 a.m. A progress report on consolidation will be given.



REACH AGREEMENT — Owen Childress, center, vice president of the Del E. Webb Development Company, Lin Price, left, president of Town Hall Center and Leo J. Wilson, presi-

dent of the Sun City Civic Association, sign the letter of agreement from the Development Company as to the construction of facilities at Community Center. Morgan Photo



WORK STARTED — Representatives of the Sun City Community Association and Del E. Webb Development Company met last week to break ground for new shuffleboard courts as part of the Community Center

expansion program. From left, they are Lin Price, Leo J. Wilson, Owen Childress, Jim Cullum, Tom Rittenhouse, Walter Schott, Dick Clark and Al Voelker.

PROPOSED PRESENTATION TO SUN CITY TOWN HALL CENTER
MEMBERS OF AGREEMENT SUBMITTED BY DEL E. WEBB DEVELOPMENT
CO. FOR PROVIDING ADDITIONAL GROUNDS AND FACILITIES, AND
ALTERATIONS AND ADDITIONS TO PRESENT TOWN HALL CENTER FOR
ADDING 1,700 RESIDENCES BEYOND PRESENT CONTRACT OF 3,500.

I. REASONS FOR MEETING AND PROPOSAL

PRESIDENT'S INTRODUCTION

In our May Town Hall Center Corporation meeting and subsequent newspaper articles, you were advised of negotiations being carried on between the Del E. Webb Development Co., and Town Hall Center. You were told that the Webb Company expect to build approximately 1,700 more residences in new units South of Peoria Avenue in addition to the 3,500 residences being attached to Town Hall Center under the present agreement.

In their planning they had set aside about seven acres at 107th Avenue and Mountain View Road for additional recreational facilities. They have however, been very anxious to avoid building another separate recreation center serving only the new units to be built, thus compounding the problems that now exist with Community Center and Town Hall Center operating independently and with separate memberships. As a result they ask us if Town Hall Center would consider the combining of the new facilities under the management and ownership of Town Hall Center on consideration of adding the additional 1,700 residences to the 3,500, thus making a total then of 5,200 so a negotiating committee was appointed from your Board to try and work out with the Del E. Webb Development Co., a fair and equitable solution for presentation to the Town Hall Board and, if approved by the Board, to the Town Hall members for vote.

On August 22, 1966, Del E. Webb Development Co., officials presented to our negotiating committee an agreement for consideration of what they propose to do if Town Hall Center will accept the 1,700 additional residences. This agreement is very much in line with the recommendations submitted to them by our negotiating committee.

We are here today to present this agreement to you for your consideration.

I do want to comment on the negotiations. Hundreds of hours were spent in investigations and conferences with many Town Hall clubs and people and in visitations to other retirement facilities in order to most accurately determine our needs

now and in the future and the best solutions for meeting those needs. We believe the Webb proposed agreement is not only fair and equitable but also meets our recommendations for future needs and expansion in a very excellent manner. The proposed alterations and additions will be of great benefit to all present and future members of Town Hall Center and Sun City, Arizona.

As the result of the above efforts the committee can now inform the residents of Town Hall Center of their results. This will be done in a brief resume in Exhibit A and Exhibit B following:

MODIFICATIONS AND ADDITIONS TO TOWN HALL FACILITIES - 107th AND PEORIA AVENUE

1. LIBRARY: Library to be relocated in the present sewing room space. Part of the dark room space to be partitioned off for a library storage room.
2. SEWING ROOM: Enlarge the sewing room by installing a pair of swinging doors into the present ceramics and art room. Replace and build additional storage cabinets in the storage room.
3. DARK ROOM: Relocate partitions, door and cabinets in the dark room.
4. REST ROOMS AND SHOWER ROOMS: Remodel present shower room. The janitor storage and basket storage area will be partitioned to enlarge the shower and dressing facilities by eight shower and dressing spaces. Add adequate water heater in the janitor storage area.
5. COPPER ENAMELING - MOSAICS - JEWELRY MAKING, ETC.: The storage room partitions between present library and enameling room will be removed. Storage shelving will be added along the north and east walls.
6. WOODWORKING: Install a door in the partition between the present wood-working shop and lapidary storage room and use all of the combined facilities for woodworking.
7. ARTS AND CRAFTS BUILDING: Construct a new building with underwriter's approved fire sprinkler system, adequate air conditioning, approximately 32' x 125', to keep all arts and crafts facilities at present Town Hall Center location. The new structure will provide space and facilities for:
 - A. Lapidary room;
 - B. Ceramics and firing room;
 - C. Art and music room;
 - D. Janitor and equipment storage.
8. SHUFFLEBOARD: New canopies will be built at the shuffleboard courts with revised lighting and equipment racks.
9. SNACK BAR: A snack bar will be located east of the existing swimming pool. The building to have necessary plumbing and electrical facilities for a short order snack bar. Kitchen equipment to be furnished by Town Hall Center.
10. No repainting will be done except that required by relocation of equipment or partitions.

NEW COMMUNITY AND RECREATION FACILITIES AT 107th AVENUE AND MOUNTAIN VIEW ROAD

1. NEW AUDITORIUM: Construct an auditorium building with adequate air conditioning to seat between 1,000 and 1,200 people, with a stage dressing rooms, chairs and a projection booth. Covered and open terraces will overlook the pool area for dining, dancing and lounging. An underwriter's approved fire sprinkler system will be installed in this building.
2. SWIMMING POOL: A swimming pool will be constructed in a completely landscaped, recessed area, with kool-decking surrounding the pool. Cabanas will be located in the southwest corner of the pool area, with toilet, shower room and basket storage building on the north side. Certain pool and terrace furniture will be provided. The recessed pool area will be accessible by two ramps from the terraces. The pool equipment will be located in the equipment area referred to in paragraph 7 of this exhibit.
3. HEALTH AND EXERCISE FACILITIES: A building with adequate air conditioning will be constructed to enclose a therapeutic pool, exercise room with certain equipment, toilet facilities and dressing rooms. This building will also include a kitchen facilities for serving catered banquets or parties. A snack bar space with necessary plumbing and electrical will be provided, kitchen equipment to be furnished by Town Hall Center. This building will have an underwriter's approved fire sprinkler system.
4. BOWLING GREEN: A bowling green with proper lighting will be provided.
5. SHUFFLEBOARD: Twelve shuffleboard courts with canopies, lighting and equipment racks will be provided. Toilet facilities will be located in a building between the shuffleboard courts and the bowling green, along with a general storage room for use in connection with the recreation area.
6. CROQUET: Four croquet courts will be located in the recreation area.
7. EQUIPMENT STORAGE: A recessed equipment yard accessible only by a service road from Mountain View Road. The pool equipment will be located in this equipment yard. A covered area will be provided for equipment storage.
8. PARKING: Parking area will be provided with ingress and egress to and from 107th Avenue and Mountain View Road.

Following Exhibit A and Exhibit B, herein is a breakdown of our present Town Hall area and a breakdown of the New Proposed Additions.

APPROX. PRESENT TOWN HALL AREAS

BUILDINGS

North - Arts and Crafts	2,904 Sq. ft.	
South - " " "	2,728	
Showers and Janitor Room	1,204	
Auditorium	7,600	
Lounge and offices	1,800	
Card rooms	2,240	
	<hr/>	
TOTAL SQUARE FOOT BUILDINGS		18,476 sq. ft.

GROUNDS

Swimming pool	3,845 Sq. ft.	
Concrete around pool	15,694	
Concrete patio and theatre area	16,457	
Bowling Green	14,400	
Shuffleboard Court	5,940	
Parking area	30,618	
Walks	18,586	
	<hr/>	
Lawns & Shrubs	84,547	105,540 sq. ft.
		<hr/>
TOTAL TOWN HALL AREA (PRESENT)		208,563 sq. ft.

APPROX. PROPOSED NEW ADDITIONS

BUILDINGS

I. TOWN HALL CENTER LOCATION *

New Arts & Crafts Bldg.	4,000 sq. ft.	
Snack Bar	600	
		4,600 sq. ft.

II. NEW RECREATION CENTER

Auditorium	9,700 sq. ft.	
Toilets & equip. storage	1,880	
Exercise & kitchen bldg.	4,960	
Pool equip. bldg.	684	
		17,224 sq. ft.
New site bldgs.		17,224 sq. ft.
TOTAL NEW BLDGS. PROPOSED		21,824 sq. ft.

GROUNDS & OUTSIDE FACILITIES

New Swimming Pool	7,293 sq. ft.	
Lawn Bowling area	22,500	
Shuffleboard	7,995	
Pool terrace area	22,977	
Terraces	9,450	
Parking	62,200	
Walks	16,520	
Service Yard	3,855	
Service road	9,300	
Shrubs & Lawns	139,211	
		301,301 sq. ft.
TOTAL OUTSIDE FACILITIES		301,301 sq. ft.
TOTAL PROPOSED BUILDINGS		17,224
TOTAL AREA NEW SITE		318,525 sq. ft.

* Figures do not include shuffleboard canopies or remodeling of Arts & Crafts rooms and shower additions.

On September 1, 1966 your Town Hall Board of Directors voted favorably on this Agreement and on certain amendments and changes in the By-Laws and Articles of Incorporation which are required to proceed with this agreement. While the Articles of Incorporation and the By-Laws give the Town Hall Board the authority to enter into contracts or agreements, in order to increase the residential areas or number of residences attached to Town Hall Center these By-Laws and Articles of Incorporation changes have to be made.

Motion was made and seconded that the Articles of Incorporation be amended as follows:

"ARTICLE I. The name of this corporation shall be SUN CITY TOWN HALL CENTER and its principal place of business shall be at Sun City, Maricopa County, Arizona, but the board of directors may designate other places within the State of Arizona where other offices may be established and maintained and corporate business transacted. Members of the corporation shall be residents of Sun City Units 2,

3, 4, 5, 6 and such additional geographical designations as may be formed, created or zoned within the bounds of Peoria Avenue, 99th Avenue, Olive Avenue and a boundary line west of 111th Avenue as shown on a map of Sun City, Arizona, identified as Exhibit "C" attached hereto." (Explained later)

ARTICLE III, Paragraph 2. Amend to read: "2. To coordinate, implement and aid the various recreational and social clubs within Units 2, 3, 4, 5, 6 and such additional geographical designations as may be formed, created or zoned within the bounds of Peoria Avenue, 99th Avenue, Olive Avenue and a boundary line west of 111th Avenue, and shown on map of Sun City, Arizona, identified as Exhibit C.

ARTICLE III, Paragraph 3. Amend to read: "3. To promote cooperation in all matters of interest and benefit to the residents of Units 2, 3, 4, 5, 6 and such additional geographical designations as may be formed, created or zoned within the bounds of Peoria Avenue, 99th Avenue, Olive Avenue and a boundary line west of 111th Avenue, as shown on map of Sun City, Arizona, identified as Exhibit C."

The following changes and/or amendments to the By-Laws were approved:

In all instances where reference is made to "Units 2, 3, 4, 5 or 6" or "Units 2, 3, 4, 5 and 6", such geographical identifications shall be changed to read "Units 2, 3, 4, 5, 6 and such additional units or other geographical designations as may be formed, created or zoned within the bounds of Peoria Avenue, 99th Avenue Olive Avenue and a boundary line west of 111th Avenue."

ARTICLE III, Section 2. Amend the first paragraph by adding the following sentence: "No member shall be denied the use of any facility of Sun City Town Hall Center, even though he has no membership in any recognized club and no recognized club shall have any rule or regulation prohibiting the use of any facility by such member."

ARTICLE III, Section 3. Add following sentence to paragraph 1: "This assessment will entitle each member to a membership card in all Town Hall activities."

BALLOT

"The proposed contract between the Del E. Webb Development Company and the Sun City Town Hall Center for the expansion of the area to be serviced by the said Town Hall Center from the present 3,500 Units to 5,200 Units and the recreational facilities be expanded as set forth in Exhibits "A" and "B" is approved."

FOR

AGAINST

A YES VOTE will include the necessary changes to our Articles of Incorporation and By-Laws which will have to be amended to honor the proposal.

***** TOWN HALL CENTER BULLETIN *****

VOL I, NO. L

February 1, 1967

The Town Hall Center Board of Directors is initiating a new service to Town Hall members beginning with this - the first issue of a news bulletin - the Town Hall Center Bulletin.

The BULLETIN is to be issued each month as a means of getting current information about Town Hall Center and the Clubs to each member household.

The Town Hall clubs and other organized activities may use the BULLETIN to publicize their special programs, activities, and plans. It is hoped that all organizations will endeavor to promptly advise the BULLETIN of upcoming events so that Town Hall people will be informed about all special events and programs, and other news or information of particular or unusual interest.

For general information and convenience of Town Hall members, there are listed in this first issue of the BULLETIN, the Town Hall officers and Board members for 1967. The Town Hall committees, with all members, are listed, and the roster of the Town Hall clubs with the present chairmen is attached.

The Public Relations Committee of Town Hall Center is responsible for issuing this BULLETIN.

The editors of the BULLETIN believe this means of getting information to Town Hall members will be helpful and solicit comments and suggestions for improvement.

*		*
*	Future issues of this BULLETIN will look a lot different	*
*		*
*	if you cooperate with us in getting the news of your	*
*		-
*	organization to us by our 20th of the month deadline.	*
*		*
*	We want all of your news and feel that all Town Hall	*
*		*
*	members are interested and will participate more with	*
*		*
*	your programs if they know all about them.	*
*		*

* * * * * TOWN HALL BULLETIN

VOL 2, No. 3

March 1, 1968

"May kindness and forbearance make
Sun City a glorious place,
Where each man feels a brotherhood
Unmarred by creed or race."

We have neither time nor space to comment on the many activities of the past weeks - Sun Bowl activities, social, civic, fraternal and many others, including the excellent work of our two Town Boards who are working so diligently toward an equitable consolidation of the two areas.

It seems 1968 promises to be the high-water mark for Sun City in facilities and activities, not only in home development, but bursting with activities in forty growing clubs, choruses, and other groups. We can't stop growth and progress when visitors "beat a path to our door" from as far away as Canada, Hawaii, and Alaska.

Musical and art programs are scheduled for the coming weeks - Liberace, chorus concerts, piano-organ concert, "The Play's the Thing", and many more listed in this Bulletin.

Better mark your March calendar now!!!

SQUARE DANCE CLUB - Change of location for one night only. Club to meet at club rooms at Peoria Avenue on March 29, 7:00 & 8:30 PM, instead of Town Hall South.

SUN CITY RETIRED TEACHERS' CLUB will meet Monday, March 18, 1:30 PM in the clubroom at the north west corner of Town Hall Center. Mr. Payne Templeton of Sun City will talk about America's concern for education in developing countries. He will mention his experience working on educational foreign aid in Latin America and the Far East.

TOWN HALL SWIM CLUB will meet Thursday, March 7, 10:00 AM in the club room next to the Lounge. Good times in the swim pools are just ahead. Come to the meeting and renew old pool friendships and make new ones. Everybody welcome.

SUN CITY AGRICULTURAL CLUB will meet at 10:00 AM Tuesday, March 5, in the clubroom at the northwest corner of Town Hall Center. Among items on the agenda for discussion are March plantings, a proposed trip to the U of A Agr. Station, the status of the Farms, and the purchase by the club of seeds, insecticides, fertilizers, and a wheelbarrow.

FRIENDS OF THE LIBRARY will hold their regular monthly meeting on Monday, March 4, 7:30 PM, in Town Hall Center. Mr. Robert D. Holtz, who for 34 years was an administrator in the Bureau of Indian Affairs, will speak on Problems of Education and Assimilation of American Indians. All residents and visitors, in addition to members, are invited to attend.

LAPIDARY "SHOW AND TELL" - The second annual "Show and Tell" will be presented on Saturday, March 9, on the Town Hall Center patio from 10:00 AM to 4:00 PM. Fifty or more members will display hand-crafted jewelry and other items which they have made in the lapidary hobby shop. Judging from the response of those visiting the show last year, a good crowd is expected. All Sun Citizens and the general public are invited. Free refreshments will be served during the show. The committee in charge is made up of Mrs. Don (Ann) Park, Walter Schroeder and Ed Fader.

SUN CITY ORGAN CLUB will meet March 7, 7:30 PM, in the Town Hall Lounge. The guest organist will be Mr. Ehrman S. Reynolds of Sun City. Mr. Reynolds is an experienced church organist as well as an entertainer at hotels and conventions playing dinner music. He studied pipe organ at Wyoming Seminary, Kingston, Pa. Also playing the organ that evening will be Mrs. Fred P. Weberlein and Miss Evelyn Erickson, Club members. Others of our membership will have an opportunity to play, so please come prepared. We are attempting to make this a participation club with enjoyment for all. Sun Citizens who are interested in organ music are invited to attend.

SUN CITY WOMEN'S CHORUS will sing on Tuesday afternoon, March 26, 1:30 PM, for the monthly meeting of the United Presbyterian Women's Association. Chorus director is Jo Gerig; accompanist Gertrude Hunt. Chorus rehearsals are held each Wednesday morning at Town Hall Center Auditorium, Room 4.

Hats Off" to the Unpaid Monitors. Their tireless effort helps make Sun City what it is.

BARBER SHOP QUARTET LOVERS

A 60-voice male chorus from the Phoenix, Saguaro Chapter S.P.E.B.S.Q.S.A., Inc., will present a program at Town Hall SOUTH Wednesday, March 27, at 7:45 PM.

TOPICS

DRIVE DEFENSIVELY

Join the SAFE DRIVING CAMPAIGN.

The life you save may be your own.

We suggest that you proceed cautiously at all intersections. In this way, we will not only protect ourselves but also our visitors who are not as familiar with our traffic patterns.

TOWN HALL ART CLUB will meet March 12, 1:00 PM, in the club room. Adrian Hanson, a well known artist in the valley will give a demonstration on the uses and techniques of acrylics. The Club will host a lecture on the "Standards of Judgment" in Art by Mr. Donne Puckle, who is Associate Director of the Phoenix Art Museum, March 18, 7:00 PM, in the Town Hall Auditorium on Peoria Avenue. Anyone interested in art is cordially invited to attend. Paintings by members of Town Hall Art Club will be on display. Registration for the new classes in art instruction will be held as follows:
Hall Abrisch - March 8 - 1:00 to 4:00 PM
Ruth Moore - March 6 - 10:00 to 12:00 N.
Hal Benson - March 8 - 9:30 to 12:00 N.
You must bring your Town Hall membership cards when you register.

PIANO-ORGAN CONCERT Plans have been made for a piano-organ concert at Town Hall South Auditorium on Sunday, March 10, 2:30 PM, with Ray Turner of Harmony House at the organ. Mr. Turner is master of music of all moods and will provide an entertaining concert for music lovers. This will be a benefit performance and your donation will be appreciated. Persons unable to attend but desiring to contribute may do so at the Town Hall office. A committee has been formed to raise funds for a piano and organ. Members of this Committee are: Reg Hauge, Chairman, Ethel Murphey, Kathleen Austin, E.W. Carson, Les Behnke, Ken Osberg and Jim Higginbotham.

* * * * *

We may draw a circle, and shut them out,
By deed, action and word of mouth,
But love and kindness has the power to win,
If we draw a circle and take them in.

* * * * *

In a business executive's office hangs a placard which reads:

* * * * *

"There is no limit to the amount of good a man can do, if he cares not who receives the credit."

TO YOU GOLFERS

The perfectionist pro says:
"Keep your eye on the ball
Your shoulder to the wheel
And your ear to the ground"
Now try to tee off in that position.

This may apply to all of us. If we are truly interested in our community, its growth, its fellowship and well being, we will forget the credit in the joy of a job well done.

* * * * *

* * * * *

TOWN HALL MOVIES FOR MARCH
AT
TOWN HALL SOUTH

MARCH 4 - Matinee 1:00 PM - Evening 7:30 PM
WALT DISNEY FESTIVAL
The Vanishing Prairie
Grand Canyon
Bear Country
The Living Desert

MARCH 11 - Evening 7:30 PM
DODGE CITY
ISLAND ODDITIES (Bahamas)

MARCH 18 - Evening 7:30 PM
LOSS OF INNOCENCE
THE LAND CALLED NEW JERSEY

MARCH 25 - Evening 7:30 PM
SON OF PALE FACE
DISCOVER HAWAII

VOL.2, No. 6

September 1, 1968

*****	*****	*****
* TOWN HALL *	* TOWN HALL *	* TOWN HALL *
* NORTH *	* CENTER *	* SOUTH *
* 10725 OAKMONT DR. *	* 10600 PEORIA AVE. *	* 9749 - 107TH AVE. *
*****	*****	*****

This is your first Bulletin after a vacation during June, July, and August for all connected with its publication including the faithful "Town Criers" who have been responsible for its distribution. Our thanks to the "Town Criers" for a job well done. (More about these faithful workers in the future.)

Because of the greatly expanded area due to consolidation and the many new homes delivered in Unit 6, your committee has decided that it will be impossible to continue door-to-door distribution as in the past.

Your Bulletin will be printed as in the past, covering items of special importance, plus special notices from all active clubs. Club notices and information should be sent to the Town Hall Center office as in the past. The deadline will be the 20th of each month.

Copies of your Bulletin, along with Del Webb's NEWS LETTER and ACTIVITY CALENDAR, will be available for pick up at TOWN HALL NORTH, 10725 Oakmont Drive, TOWN HALL CENTER, 10600 W. Peoria Ave., and TOWN HALL SOUTH, 9749 - 107th Avenue. We will attempt to make this pickup as convenient as possible for you and we are sure it will contain valuable information. Both the Sun Citizen and News-Sun inform us they will continue to print the WEEKLY ACTIVITIES CALENDAR, as in the past.

* NOTICE *

* First Quarterly Meeting of the Sun City Community Association *

* Town Hall South, 9749 - 107th Ave. *

* 1:30 PM September 9, 1968 *

All former members of the Sun City Civic Association, and Town Hall Center, automatically became members of the new Sun City Community Association, Inc., as a result of the consolidation May 8, 1968. Your membership card to either Sun City Civic Assn. or Town Hall will admit you. Plan to attend and meet your new officers. This will be the first opportunity to learn of the progress of your new corporation. Mark your calendar now and plan to attend.

This has been in effect for some months now, but since so many have been away, we want to repeat it. If you are an activity card holder, all facilities at any location in Sun City are available for your use.

All pools are open and operating. Rules are being published in the News-Sun and Sun Citizen and will be posted at each pool.

The new shuffleboard courts at Town Hall North will be completed and usable by Sept. 15th.

The Lawn Bowling green at Town Hall North will be closed for several weeks for complete Fall renovation. The other courts will be open as usual.

The grape-vine tells us your Organ Committee came up with a "hot deal" for a new Thomas Organ. They couldn't pass it up. SO-o-o-o-o they bought it. Furthermore, it will be delivered pronto. Keep your donations coming in, folks, since the deal did not include the two external speakers required. The key will be maintained at Town Hall Center and will be presented only to qualified organ players.

SATURDAY NITE DANCE CLUB
Registration for dance instruction classes will be held at 7:00 PM Friday, Sept. 13, at Town Hall Center Auditorium, 10600 Peoria Avenue. Come out and renew old acquaintances.

ROSE AND GARDEN CLUB - will meet Tuesday, Sept. 10, 7:30 PM at Town Hall North Auditorium, 10725 Oakmont Drive. THE CHANGE OF MEETING PLACE IS FOR SEPTEMBER ONLY.

SUN CITY ORGAN CLUB will meet in Room B in the Club Room east of Town Hall Center Lounge, on Friday, Sept. 6, at 7:30 PM. All Sun Citizens who are interested in organ music are invited to attend. Our guest artist will be Mr. Richard Kaysen, Administrator of Sun Valley Lodge.

TOWN HALL LAPIDARY CLUB will start its Fall season with a meeting of its members on Friday, Sept. 6, at 1:30 PM in Club Room #1. All members are urged to attend. Formal instruction of trainees will begin Friday, Sept. 13. All trainees are requested to contact the monitor at the shop so reservation may be made with the instructors.

MOVIES

TOWN HALL SOUTH AUDITORIUM
MONDAY 7:30 PM

- Sept. 16 - "TEN WHO DARED" - Brian Keith, John Beal, David Stollery
"WILD RIVERS" - Adventure film - magnificent photography
- Sept. 23 - "MOVE OVER, DARLING" - Doris Day, James Garner, Polly Bergen,
Chuck Connors, Thelma Ritter, Don Knotts
- Sept. 30 - "KING SOLOMON'S MINES" - Deborah Kerr, Stewart Granger,
Richard Carlson.

LAWN BOWLS CLUB - Summer hours effective through September:

TOWN HALL CENTER GREEN - Tuesday,
Thursday and Saturday.
TOWN HALL SOUTH GREEN - Tuesday,
Wednesday and Friday.
Hours at both locations - 8:00 AM and
7:30 PM.

Instruction classes - Town Hall Center,
Mondays and Wednesdays at 7:30 AM. Begin-
ners class Thursdays at 7:30 AM. Ladies
day every 4th Tuesday. Next business
meeting will be September 9th at 10:00 AM
in the Art Room at Town Hall Center.

SUN CITY WOMAN'S CHORUS will resume weekly
rehearsals on Wednesday, Sept. 4, at 9:30 AM
in Room A-3 at Town Hall Center Auditorium.
Several programs are already planned,
including the annual Christmas Concert
presently scheduled for December 8th at
Town Hall South. Any women interested in
singing three-part music should contact
Jo Gerig, Director, 933-0085; Evelyn Robb,
Chairman, 933-0335; or Ethel Murphey,
933-2672.

SENIOR WOMEN'S LEAGUE - On Sept. 19th at
10:00 AM in Town Hall South, Chairman
Dolores Adams will sound her gavel to open
the 1968-69 meetings of the Senior Women's
League. Mr. Wendell R. Newell, Superintend-
ent of Arizona Boys' Ranch, will speak on
"The Subject is Boys." He speaks with
authority, "know how", and compassion about
his boys. Beth DeCoursey and her pro-
gram committee have planned an exciting
series of meetings for the year. We won't
tell you all that will happen, but just to
make you curious, some key words are
International pageant, decorations, music,
murals, theater, children, books, and travel.
484 members of S.W.L. cordially invite all
Sun City women holding current activity cards
to join with us once a month on the third
Thursday each month in Town Hall South for
FACTS, FUN AND FELLOWSHIP.

SUN CITY AGRICULTURAL CLUB - After a summer
vacation, the club will resume its monthly
meetings Tuesday, September 3rd at 10:00 AM
in the club room at the NW corner of Town
Hall Center. It is hoped that Mr. Childress
will attend this meeting. Possibly
Mr. McClung's committee will have a report.
The county agent recommends the planting
of 19 vegetables in September.

CONTINENTAL DANCE CLUB continues to meet on
the 2nd and 4th Wednesdays of each month
at 8:30 PM, Town Hall South, 9749 107th Ave.

CERAMIC CLUB - Activities for September.
The next business meeting of the Ceramic
Club will be 9:00 AM Sept. 9th at the
Town Hall Center Club room. A good turnout
is expected as there shall be new classes
and new business to be discussed. Both
old and new members are urged to attend so
that the fall program can be a great success.
It is planned to have guest instructors,
classes in stains, glazes, antiquing,
decoupage and free form. New molds will
be added for more interest in casting.
Information is written on blackboard in
club room informing members of weekly
changes in program.

SUN CITY HAND BELL RINGERS will start fall
activities on Sept. 5th when the Thursday
group will report for rehearsal at Town
Hall Center at 9:00 AM. The Friday group
will report at 9:30 AM on Sept. 6th. We
are grateful to Mr. & Mrs. Howard Lentz
for their generosity in providing us with
one more octave of handbells. We now
have 37 handbells and we need additional
ringers. Those interested please call
Mrs. David Gerig, director, 933-0085, or
Mrs. Edward Austin, 933-2578.

Make a tour of Town Hall North, 10725 Oakmont Drive, and see the new pool facilities
and the new building housing sewing, art, and bridge clubs.

Town Hall Center, 10600 Peoria Avenue, has been renovated and redecorated.

Town Hall South, 9749 - 107th Avenue, is more beautiful than ever with the grass and
shrubbery in full color. More changes will come. We believe you will be proud of
YOUR expanded facilities.

VOL. 3, No. 5

May 1, 1969

ATTENTION -- ALL SUN CITY RESIDENTS

The next regular quarterly meeting of the Sun City Community Association Corporation will be held Monday, May 12, 1969, at 1:30 PM at Town Hall, South.

Please mark your calendars and plan to attend this very important meeting. You will be rewarded with the personal satisfaction of your participation in Corporation activities.

Douglas V. Lowther
Public Relations Chairman

MEN'S CLUB ACTIVITIES FOR MAY

- 1 -- Bingo Parties -- May 14 and 28 -- 7:00 PM
- 2 -- Golf Tournament -- May 12 -- South Course-- best ball foursome.
- 3 -- Mother's Day Pancake Breakfast -- May 10 -- 8:00 to 10:00 AM. Town Hall Center Auditorium. Wives are welcome and there will be no charge.

The Club Rooms are located at Town Hall North and are open from 12 Noon until 5:00 PM -- on Saturdays, from 12 Noon until 5:00 PM. Lunch is served on Saturdays.

THE SUN CITY MALE CHORUS

Forty-eight men will present an evening of song on Sunday, May 4th at 8:00 PM in Town Hall South. The songs will include numbers from Fred Waring's and Robert Shaw's Choral Series and several pieces will feature soloists. This will be the final public appearance for the 1968-69 season of this group under the direction of Mark Cassells and with accompanist Esther Weiss. There will be ample seating for a large audience. Those attending will have an opportunity to make a free-will offering which will be used for their music library and necessary equipment for next year's program which will be the start of their seventh year.

ON MOTHER'S DAY

By Robert W. Norris

Could I but write to Mother
In that home so far away
And say how much I think of her
On this dear Mother's day.
Of the lessons that she taught me
As I knelt down by her knee,
The man that in the future years
She hoped that I would be.

The passing years cannot erase,
From out my memory,
The vision of her kindly face,
And all she did for me.
So when I think of all these things,
For which I can't repay,
It reminds me of the debt I owe,
On this dear Mother's Day.

THE FRIENDS OF THE LIBRARY will hold their regular monthly meeting at 1:30 on May 5th at Town Hall Center. Mr. Robt. H. Bucknam will speak on "Inflation or Deflation", Government Policy and the Investor, 1969. Mr. Bucknam has had many years experience in investment counselling.

EDITORIAL

It is said that high above the earth with its clutter of haste and confusion, all celestial movements and sounds blend into a perfect harmony - a symphony of all the spheres.

How foolish then are our petty divisions and differences. We all learned to clothe, shelter, and provide for our many needs. The same sun shone upon us all, and the same Mother Earth will care for us when our days are over.

Verily, life is too short for hate, too hard for greed, too bitter for selfishness and misunderstandings, and too lonely for unkindness. We were born free and equal - we are brothers all.

The month of May is known as moving time in most northern states, while many southern families migrate northward into higher altitudes and cooler areas. And yet, there are those of us who enjoy the climate of the Valley of the Sun. We even enjoy playing hosts to friends, relatives, and those dear grandchildren.

May you all have a most pleasant and enjoyable summer vacation. So - "Aufwiederschen" until September.

SENIOR WOMEN'S LEAGUE

Meeting on May 15th at 10:00 AM in Town Hall South for their annual luncheon and installations of 1969-70 officers. Members of the Phoenix Junior Symphony will present the program. Tickets at \$1.75 are available from Mrs. Ralph Pickering, 933-4202, and Mrs. Harold Nass, 933-0382.

TOWN HALL SWIM CLUB -- Regular business meeting at 10:00 AM Thursday, May 1st, on the Patio back of Town Hall Center office. Coffee and rolls will be served to members and their guests.

TO GRANDMAS

While we're honoring our mothers
With songs and words of praise
While we tell about their kindness
And their tender loving ways
We should like to honor grandmas
They are mothers too, tho old
For they mothered our dear mothers
In the fond memories we hold.

A THOUGHT

You have never lived a "perfect day"
even tho' you have earned your wage,
unless you have done something for some-
one who will never be able to repay you.

SUN CITY AGRICULTURAL CLUB will meet May 6th at 10:00 AM, Town Hall Center Auditorium. The proposed rules and regulations will be re-read, discussed, and voted on. It is expected that new gardening plot will be piped and staked by May 1st. If completed, plots will be assigned at meeting.

THE MANAGER REQUESTS:

To cut down on expense of set-ups, it is important for the clubs to notify the office of all changes or cancellations. Phone 933-0127.

Deadline for Town Hall Calendar is the 15th of the preceding month.

SUN CITY ORGAN CLUB - Meeting will be held Wednesday, May 7, 1969, at Town Hall South 7:30 PM. The program will be Piano and Organ duets by the following members: Mrs. Carrie Arlt and Mrs. Lucille Weberlein; Mrs. Blanche Lesser and Mrs. Dorothea Schu- lenberg. The Club is very fortunate to have as many talented members who have enter- tained at the meetings. No doubt there are others just as talented who haven't ventured or offered to play. This is their chance to play the fine organ at Town Hall South before an audience and among friends - hope they will take advantage of it soon. There will also be a discussion regarding the Organ Parties to be held for those who remain in Sun City during the summer.

TOWN HALL LADIES' GYM CLASS--will hold their annual Spring Party starting at 9:00 AM in Town Hall Center Monday, May 12. There will be lots of fun, food, entertainment and re- freshments. Lots of "Double Hitches", "Twinkles", "Grapevines", "Twirls", "Boxes", "Ringing of Bells", "Scissors" and What- Have-You! Some surprises too!

ROSE AND GARDEN CLUB - Due to change in pro- gramming, the Rose & Garden Club in the future will meet on the 2nd Monday of each month in the Auditorium of Town Hall Center. The next meeting will be May 12th at 7:30 PM. Be sure to bring your roses for judging and presentation to the Sun Valley Lodge.

ART CLUB PICNIC - All members are urged to bring their sketch books and lunches for a sketching picnic to be held at Bumble Bee on May 13th. The caravan to Bumble Bee will meet at the Safeway parking lot in Plaza del Sol at 9:30 AM.

SUN CITY ROCKHOUND CLUB - The next meeting will be held on Monday evening, May 12th, at the Club Rooms at Town Hall Center. The guest speaker for the evening will be Michael Sheridan, A.S.U. Geology Dept., who will speak on examining rocks with Polorizing microscopes. Plans will also be finalized at that time for a 3-day field trip May 20, 21, and 22 to the Do-Bell Ranch near Holbrook to look for petrified wood and picture wood. Arrange- ments will be made for those who wish to camp out at the Ranch; otherwise members may spend the night at a motel in Holbrook or other nearby towns. Guests and friends are welcome to attend the meeting and arrange to go on the field trip.

Go often to the house of thy friend, for weeds soon choke up the unused path.

TOWN HALL MOVIES

NOTE CHANGE IN DAY - TUESDAY INSTEAD OF MONDAY TOWN HALL SOUTH AUDITORIUM TUESDAYS 7:30 PM NOTE CHANGE IN DAY - TUESDAY INSTEAD OF MONDAY

- TUESDAY, May 6th - "THE GEISHA BOY" - Starring Jerry Lewis, Marie McDonald, Sessue Hayakawa, Suzanne Pleshette, Barton McLane, and guest stars, The Los Angeles Dodgers.
TUESDAY, May 13 - "BEND OF THE RIVER" - Starring James Stewart, Rock Hudson, Julie Adams and Arthur Kennedy.
TUESDAY, May 20 - "OPERATION PETTICOAT" - Starring Cary Grant and Tony Curtis.
TUESDAY, May 27 - "FLUFFY" - Starring Tony Randall, Shirley Jones, Edward Andrews and Howard Morris.

IMPORTANT NOTICE

ON MEMORIAL DAY, FRIDAY, MAY 30, ALL EVENTS WILL BE CANCELLED AND THE FACILITIES WILL BE CLOSED.

THE SWIMMING POOLS WILL REMAIN OPEN.

TREES

(Not by Joyce Kilmer)

I think that I shall never see
Along the road, an unscrapped tree
With bark intact and painted bright
That no car ever hit at night.
For every tree that's near the road
Has caused some auto to be towed.
Sideswiping trees is done a lot
By drivers who are not so hot.
God gave them eyes so they could see,
Yet any fool can hit a tree.

America is a wonderful country -
where else can you walk out of your
mortgaged home, step into a time-payment
car, and drive down a freeway on credit
gas to charge something at your
favorite store.

Doing nothing is the most tiresome job
in the world because you cannot quit
and rest.

YOUR SUN CITY COMMUNITY ASSOCIATION BOARD OF DIRECTORS wishes to remind you of all the following important events of vital interest to all:

The regular QUARTERLY MEETING of the SUN CITY COMMUNITY ASSOCIATION CORPORATION will be on NOVEMBER 10, 1969, at 1:30 PM at Town Hall South. The agenda of this meeting will include report of the Nominating Committee and nomination of candidates for the BOARD OF DIRECTORS for 1970.

A joint election with the Sun City Home Owners Association will be held at Town Hall South on Thursday, December 4, 1969. Exercise your franchise for the continuation of constructive and progressive management of the wonderful facilities provided the membership in this beautiful city.

Support your annual Sun City Arts & Crafts Show to be held at CHRIS-TOWN CENTER November 6 through November 8, 1969. Chairman Mrs. Ida Mae Schwartz and Co-Chairman Mrs. Bertha Cox report the show will be worthwhile and interesting with many clubs participating.

Mailing the Town Hall Bulletin to each residence is beset with many costly problems that will take some time to solve. During this interim period, arrangements have been completed with Safeway Stores to place containers for Bulletin distribution in each store beginning on November 1, 1969 for the convenience of all concerned. Our gratitude to the Safeway Store managers for their wholehearted cooperation. Further study for more distribution locations will continue and progress reports will be made periodically.

The 10th Anniversary of Sun City will be celebrated all the month of January 1970 with many parades, shows, tournaments and the dedication of the new Lakeview Center. A committee composed of representatives of the Del E. Webb Corp., Merchants Ass'n., and Community Ass'n. Directors, are busy formulating plans and schedules of events and when completed will be given adequate and timely publicity for all to attend.

WOMEN'S CHORUS will participate in the "Sun City Day" program at the Arizona State Fair, on the morning of Nov. 6, 1969 10:00 AM to 12:00 Noon, at the Fair Grounds in Phoenix. The program is sponsored by the Del E. Webb Corp., and Jerry Svendsen will act as Master of Ceremonies.

Plans for the annual Christmas program, to be given at Town Hall South on Sunday evening, December 7th, are well under way, and tickets may be purchased now from any member of the Chorus. \$1.00 donation.

AGRICULTURAL CLUB will meet Tuesday, November 4th, in Room B-1, at Town Hall Center, at 10:00 AM.

TOWN HALL SWIM CLUB - regular business meeting will be at 10:00 AM Thursday, November 6, in Room B-1, Town Hall Center clubhouse. Agenda will include appointment of a nominating committee to select candidates for office for the year 1970.

HANDBELL RINGERS are diligently practicing for their participation in "Sun City on Stage" November 6th at the State Fair, and for their joint concert December 7th at Town Hall South with the Male and Women's Choruses. Tickets may be obtained from any Handbell Ringer. Anyone with a musical background wishing to audition for ringing should contact Director Jo (Mrs. Dave) Gerig, 933-0085.

SUN CITY PLAYERS will present "TAKE YOUR MEDICINE", a three-act comedy, where all the action takes place in a room of the Boswell Memorial Hospital and centers around two male bed patients, a sour-puss head nurse, three pretty regular nurses, and a dumb-dora student nurse.

The show will be given as a benefit for the Boswell Memorial Hospital Auxiliary on Tuesday and Wednesday, November 18th and 19th, at Town Hall South. Please buy tickets.

FRIENDS OF THE LIBRARY - At the regular monthly meeting, Dr. John F. Prince, President of the Maricopa County Junior College District, will review "IN THIS HOUSE OF BREDE", the latest novel of Rumer Godden, which has already made the best-seller list and will be available at the Sun City Library. The public is invited to attend this meeting at 1:30 PM November 3rd, in the Center Auditorium.

CONTINENTAL DANCE CLUB has changed the starting time of its dances from 8:30 PM to 8:00 PM. In the future, the dances will be from 8:00 PM till 9:30 PM. The club holds dances each month on the second and fourth Wednesdays at Town Hall South.

ROUND DANCE CLUB - Meeting at Town Hall Center every Monday, will change their set-up. Starting November 3rd, beginners classes will be from 8:30 to 9:30 AM; Intermediate from 9:30 to 11:00 AM, at Town Hall Center.

The GYM CLASS will be a separate class, meeting on Friday, November 7th and every Friday thereafter, from 8:30 to 9:45 AM, at Town Hall South.

Doing nothing is the most tiresome job in the world, because you cannot quit and rest.

MEN'S CLUB - meets each day at Town Hall North 12:00 to 5:00 PM, except Sunday and Holidays. On Saturday, 11:00 AM to 5:00 PM with lunch served beginning at 11:00 AM.

A golf tournament will be held for club members only on Nov. 10th at the North Course. Golfers can sign up at the North or South course not later than Wednesday, Nov. 5th. If you don't have a handicap but would like to play, see Gordon Evans.

A Bingo Party will be held on the 2nd and 4th Wednesdays of the month at Town Hall Center at 7:30 PM Sharp. Any Sun City resident with an activity card, and guests, are welcome.

Tickets are on sale at the club rooms for \$5.00 each, including Bus Fare, to a Ice Hockey Game at the Coliseum between the Phoenix Road Runners and the Vancouver Canucks. Bus will leave the Club Rooms at Town Hall North at 6:30 sharp. Bring the Ladies. We'll have a good time. We will also feed you all the peanuts and popcorn you can eat. The date for this game is Friday, Nov. 14th.

Please keep in mind our big Christmas party to be held on Friday, Dec. 19th, at Town Hall South. Tickets will go on sale at our club rooms on Nov. 1st and the deadline for tickets will be Dec. 10th. Tickets are \$5.00 each. All seats are reserved, so

please get yours early and get the best ones. Dutch treat at the cocktail hour from 6:00 to 7:00 PM. Deluxe dinner served from 7:00 PM to 8:30 PM. A few minutes for club business and then the Stage Show featuring the Sun City Male Chorus, Mr. Mark Cassell, Director; the Sun City Bell Ringers, Mrs. Jo Gerig, Director; the Wesley Methodist Church Choir, all colored cast, singing gospel songs; and two professional entertainers who will be in the Valley at this time to complete our program. Music will be furnished during the cocktail party by the Rhythm Ramblers of Sun City, and during the dinner by Mrs. Blance Lesser at the organ. You are all welcome to come. Every one with an activity card.

Election of officers for 1970 at Club Rooms, Saturday, Nov. 1st, Town Hall North. Polls open from 11:00 AM to 4:00 PM by secret ballot. The candidates are: Leslie Boyd, Alex Makarov, Lowell Elmore, Lloyd Wheadon, Rodney Estey, Amos Whitlock, George Tabor, Earl Corder, John Lagberg, Ernie Shields, Carl Schuetze, Ross Anderson and Clyde Butler.

NOTICE TO ALL CLUBS

Please have your club information for the Bulletin in by the 20th of each month.

PLEASE HAVE INFORMATION FOR THE TOWN HALL CALENDAR IN THE OFFICE ON OR BEFORE THE 15th OF THE PRECEDING MONTH. THE HEAVY SCHEDULE ON ALL FACILITIES REQUIRES MORE TIME IN THE ALLOCATION OF SPACE AND PREPARING THE CALENDAR. SEND TO ATTENTION OF RILL ABRISCH.

OUR FLAGS AT HALF MAST

Henry Ward Beecher said in 1887: "Our flag means all that our fathers meant in the Revolutionary War; It means all that the Declaration of Independence meant; it means all that the Constitution of our people organized for Justice, for Liberty and for Happiness, meant."

TOWN HALL MOVIES
TOWN HALL SOUTH AUDITORIUM
TUESDAYS 7:30 PM

- | | | |
|-----------------------|----------------------------------|--|
| TUESDAY - Nov. 4th - | "THE LIVING DESERT" - | An Academy Award winner. Full length true life adventure. |
| TUESDAY - Nov. 11th - | "OKLAHOMA" - | Gordon MacRae, Gloria Grahame, Shirley Jones, Gene Nelson, Eddie Albert, Rod Steiger. |
| TUESDAY - Nov. 18th - | "TAKE YOUR MEDICINE" - | Live - Three-Act Comedy by the SUN CITY PLAYERS, FOR the benefit of the Boswell Memorial Hospital Auxiliary. |
| TUESDAY - Nov. 25th - | "THE TREASURE OF SIERRA MADRE" - | Humphrey Bogart, Tim Holt, Walter Huston, Bruce Bennett. |

Cooperation will solve most of our problems. Freckles would make a nice coat of tan if they could only get together.

* * * * *

* IMPORTANT IMPORTANT IMPORTANT *

* ANNUAL ELECTION TO THE BOARD OF DIRECTORS *

* DATE: Thursday, December 4, 1969 *

* TIME: 10:00 AM to 6:00 PM *

* PLACE: TOWN HALL SOUTH AUDITORIUM *

* Mark your calendar NOW. Come out and VOTE! Be an active PARTICIPANT, not a spectator. Elect and support your Sun City Community Association Board of Directors for continued progressive and efficient management of the myriad of complex problems faced in the operation of the facilities for all members in this beautiful city. Remember Civic Pride is the only remuneration received by any board member. *

* NOTE: BRING YOUR CURRENT ASSOCIATION MEMBERSHIP CARD TO VOTE *

* * * * *

NOTICE: A SPECIAL ELECTION NEWS BROCHURE HAS BEEN PREPARED AND IS AVAILABLE AT ALL TOWN HALLS, IN THE BUSINESS OFFICE, AND FROM CLUB CHAIRMEN.

REMINDER: Plans and schedules for the Dedication of the LAKEVIEW Recreational Center, and the Tenth Anniversary Celebration of SUN CITY are rapidly nearing completion. All available news media will be used so that all residents can be informed relative to the continuing program during the month of January, 1970.

THE BOARD OF DIRECTORS AND STAFF OF THE SUN CITY COMMUNITY ASSOCIATION WISHES TO EXTEND TO ALL RESIDENTS AND ASSOCIATES A VERY MERRY CHRISTMAS AND A HAPPY NEW YEAR. MAY YOU HAVE A JOYOUS YULETIDE SEASON WITH PEACE, HARMONY AND LOVE OF YOUR FELLOW MAN PREVAILING.

The Public Relations Committee, consisting of Douglas V. Lowther, Chairman, Mrs. Fern Marion, Mr. Lyle F. Gibbon, Mr. Edward H. Roos and Mr. Alvin H. Hanson, take this opportunity to thank one and all for their help and guidance in the preparation of this bulletin and details of the Association's Public Relations duties. Our personal Holiday Greetings to all.

WOMAN'S LEAGUE will have their annual Christmas luncheon on December 18th in Town Hall South. A program of Carols will be presented by Peoria Elementary School children at 10:00 o'clock. Tickets are available for members and house guests only.

GIRL'S RANCH AUXILIARY OF SUN CITY will meet in Club Room B, Town Hall Center, December 10th at 9:30 AM. The Nominating Committee will report and the 1970 officers will be elected. There will be Christmas entertainment and refreshments. Each member will bring a wrapped gift for one of the girls in the Ranch Homes. Call 933-5889 or 933-4607 for further information.

TOWN HALL CENTER SWIM CLUB will hold its monthly business meeting at 10:00 AM Thursday, Dec. 4th, at Town Hall Center, Room B. The agenda will include election of officers for 1970. Light refreshments will be served.

THE FRIENDS OF THE LIBRARY will meet Monday, December 1st, at 1:45 PM, in the Town Hall Center Auditorium. The Chamber Singers of Glendale Community College will present a Christmas Musical program. A tea will follow. Non-members are cordially invited both to the tea and program. There will be a short business meeting held before the program and Miss Dorothy Weber, Sun City Librarian, will tell about the latest library developments. Please note slight change in time.

AGRICULTURE & RELATED INDUSTRY GROUP meets the second Wednesday of each month for breakfast at 8:00 AM, Howard Johnson's Restaurant. There is no membership fee, and each one pays for his own breakfast. There is a program at each breakfast on some important subject about a phase of agriculture, farming, or ranching. Chairman - Harry J. Boyts, 933-3694; Secretary Earl Manthey, 933-5478.

CONTINENTAL DANCE CLUB will hold their regular dance on December 10th, but there will not be a dance on the evening of December 24th.

CHRISTMAS PARTY - Town Hall Center Round Dance & Gym Classes, and Town Hall North Rhythm Class will join together for a Christmas party at Town Hall South on Monday, December 15th, starting at 10:00 AM.

SUN CITY ART CLUB will hold their annual Christmas party in the Town Hall Center Auditorium on December 17th at 6:30 PM. The regular monthly business meeting will be on December 9th in the Town Hall Center Art Room at 1:00 PM.

ROSE & GARDENCLUB CHRISTMAS PARTY - 5:30 PM
Monday, December 8th, at Town Hall Center Auditorium. Turkey, ham and coffee will be furnished free for this pot-luck. Bring a casserole or dessert and your own table service.

Mr. Wendell Noell will entertain with two squares of Exhibition Square Dancers, with a professional caller, which you will enjoy. Make this evening a Big Fun Christmas Party to wind up the year.

Bring your Roses -- this is the last time to enter Roses for our Little Show. A trophy will be awarded for the highest point winner at the January 12th meeting. We hope to have Mr. Lewis Whitworth, Professional Citrus Consultant, on our program. Last January, his lecture and demonstrations on citrus trees of all kinds was very well received. New residents will enjoy this informative program very much. Everyone welcome.

CONTAGIOUS

Friendliness is contagious. The trouble is, many of us wait to catch it from someone else, when we might better be giving them a chance to catch it from us.

- - -

He has the right to criticize
who has the heart to help.
Abraham Lincoln

- - -

CHRISTMAS CONCERT - There will be a combined musical presentation by the Women's and Male Choruses, and the Handbell Ringers of a "Cavalcade of Christmas Music" on Sunday, December 7th, at 8:00 PM, in Town Hall South. This will feature all three of these groups of 125 voices and musicians offering pleasing selections appropriate for the Holiday Season.

Tickets are available now thru members of all three of the participating groups, or by calling 933-0085, 933-0397, or 933-4666 or at the door the night of the concert for a donation of \$1.00 per ticket.

MEN'S CLUB - meets each day at Town Hall North, 12:00 PM to 5:00 PM, except Sundays and holidays. Lunch served at 11:00 AM to 5:00 PM on Saturday.

December 3rd is the last day to sign up for the Dec. 8th golf tournament. See Gordon Evans for your handicaps. A trophy and prizes will be awarded each flight at our Christmas party. A Bingo party is held the 2nd and 4th Wednesdays at Town Hall Center at 7:30 PM. Any resident of Sun City with a current activity card, and guests, are welcomed. There will not be a Bingo party on December 24th. Remember the Christmas Party on Friday, Dec. 19th, Town Hall South. Get your tickets now - \$5.00 donation. The Rhythm Ramblers, Mrs. Blanche Lesser, organist; the Handbell Ringers; Sun City Male Chorus; Wesley Methodist Church Choir, an all colored singing group; and two professionals, Mr. Jerry Allen, comic Banjo, and Mr. Herbie Sells, comedian, will be our All-Star Christmas Show.

TOWN HALL MOVIES
TOWN HALL SOUTH AUDITORIUM
TUESDAYS 7:30 PM.

Tuesday - December 2nd -	"A SONG TO REMEMBER"	- Starring Paul Muni, Cornell Wilde, Merle Oberon.
Tuesday - December 9th -	"TEN WHO DARED"	- Brian Keith, John Beal, James Drury.
Tuesday - December 16th -	"THE MAGNIFICENT REBEL"	- Walt Disney's Dynamic story of Ludwig Von Beethoven.
Tuesday - December 23rd -	"RUN, APPALOOSA, RUN" "ONE DAY AT TETON MARSH"	Walt Disney's action filled story about an Indian girl.
Tuesday - December 30th -	"MARY, MARY"	Debbie Reynolds, Michael Rennie, Barry Nelson, Diana McBain.

NOTICE TO ALL CLUBS

PLEASE HAVE YOUR CLUB INFORMATION FOR THE BULLETIN IN BY THE 20TH OF EACH MONTH.

PLEASE HAVE INFORMATION FOR THE TOWN HALL CALENDAR IN THE OFFICE ON OR BEFORE THE 15TH OF THE PRECEDING MONTH. THE HEAVY SCHEDULE ON ALL FACILITIES REQUIRES MORE TIME IN THE ALLOCATION OF SPACE AND PREPARING THE CALENDAR. SEND TO ATTENTION OF RILL ABRISCH.

PLEASE INFORM THE OFFICE, AS SOON AS POSSIBLE AFTER YOUR ELECTION, THE NAMES, ADDRESSES AND TELEPHONE NUMBERS OF YOUR 1970 OFFICERS.

January 1, 1970

VOL. 4, No. 1

SUN CITY CELEBRATES ITS 10TH ANNIVERSARY - 1960-1970

The calendar of events in January are available at all distribution points. It is hoped that all Sun City residents will participate in the events of their choosing.

SUN CITY CONTINENTAL DANCE CLUB will hold their first dance of 1970 on Wednesday, January 14th. At that time the new officers for 1970 will be inducted.

SUN CITY SPORTSMEN'S CLUB - To our new neighbors who have recently joined us here in Sun City - - A very warm welcome. This is one of the best States in the country for all outdoor activities. If you are interested in anything from bird watching to a big game hunt, do join us every third Monday of the month at 9:30 AM in the B and C clubrooms in Town Hall Center.

The Sun City Sportsmen's Club is affiliated with the Arizona Wildlife Federation and can supply information on where and when to fish and hunt. We can even find partners for you so you won't have to do these activities alone. We also have Archery enthusiasts who will teach, compete, or hunt, with you. We have guest speakers from the Arizona Wildlife Federation show pictures and inform us of all the interesting areas in the State.

Do come and join us January 19th at 9:30 A.M. for a fun-filled morning. Mr. Jack Mantle of the Arizona Fish and Game Commission will show slides and give a commentary of his 3-month African Safari this past summer. Refreshments will be served.

FRIENDS OF THE LIBRARY - Mr. Jack McDonald of the Public Relations Department of the Arizona Public Service Company will address the Friends of the Library at the next meeting Monday, January 5th, at 1:30 PM in the Town Hall Center Auditorium. His subject will be Here's to the Ladies: Women in Books. All Sun City residents are cordially invited.

SUN CITY ROSE & GARDEN CLUB will meet on Monday, January 12th, at 7:30 PM, at Town Hall Center. Activities will include a demonstration of proper rose pruning; presentation of Trophy to the 1969 winner of the Little Rose Show; and installation of new 1970 officers. There will be an outside demonstration of Rose pruning by a Maricopa County Agricultural Agent on Friday, January 16th, at 9:30 AM in the garden of Mr. & Mrs. Herbert Gillis, 9922 Edward Drive. Everyone is welcome.

SUN CITY WOMAN'S CHORUS will resume rehearsals on Wednesday, January 7th at 9:30 AM in the Town Hall Center Auditorium. Chorus officers for 1970 are: Chairman Harriet Bush; Vice-Chairman Ida Argersinger; Secy-Treasurer Gladys W. Queen; Librarian Louise Beemster. Chorus director is Jo Gerig, with Dorothy Giebelstein accompanist.

The Chorus will participate in the 10th Anniversary celebration program on the afternoon of January 17th in the Sun Bowl.

SUN CITY MEN'S CLUB meets in Town Hall North club rooms, 12:00 Noon to 5:00 PM daily except Sundays and holidays. Lunch served at 11:00 AM Saturdays.

Next golf tournament January 12th, North Course. Medal play, full handicap. Sign up for starting time either North or South Course by Wednesday, January 7th.

\$2.00 dues may be mailed in for 1970 membership cards to P. O. Box 519.

January Bingo parties Town Hall Center 7:30 PM Wednesday January 14th and 28th. Community Association activity card holders and house guests invited.

THE NEXT QUARTERLY MEETING OF THE SUN CITY COMMUNITY ASSOCIATION WILL BE HELD AT TOWN HALL SOUTH ON JANUARY 12, 1970 AT 1:30 PM, AT WHICH TIME THE NEWLY ELECTED MEMBERS OF THE BOARD WILL BE PRESENTED. PLEASE MARK YOUR CALENDARS AND PLAN TO ATTEND.

NOTICE ! ALL SUN CITIANS

SUN CITY COMMUNITY ASSOCIATION MEMBERSHIP DUES ARE NOW DUE. THEY MAY BE PAID AT THE TOWN HALL CENTER OFFICE ANY WEEKDAY FROM 9:00 AM TO 5:00 PM

NOTICE TO ALL CLUBS

PLEASE HAVE YOUR CLUB INFORMATION FOR THE BULLETIN IN BY THE 20th OF EACH MONTH.

PLEASE HAVE INFORMATION FOR THE TOWN HALL CALENDAR IN THE OFFICE ON OR BEFORE THE 15TH OF THE PRECEDING MONTH. THE HEAVY SCHEDULE ON ALL FACILITIES REQUIRES MORE TIME IN THE ALLOCATION OF SPACE AND PREPARING THE CALENDAR. SEND TO ATTENTION OF RILL ABRISCH.

PLEASE INFORM THE OFFICE, AS SOON AS POSSIBLE AFTER YOUR ELECTION, THE NAMES, ADDRESSES AND TELEPHONE NUMBERS OF YOUR 1970 OFFICERS FOR THE CLUB ROSTER.

* * * * *

DON'T FORGET TO ATTEND THE QUARTERLY MEETING OF THE SUN CITY COMMUNITY ASSOCIATION - 1:30 PM JANUARY 12, 1970 - TOWN HALL SOUTH AUDITORIUM - TO MEET YOUR NEW OFFICERS AND BOARD MEMBERS.

TOWN HALL MOVIES

Town Hall South Auditorium
Tuesdays 7:30 PM.

- Tuesday, January 6th - "I'D RATHER BE RICH" - Starring Robert Goulet, Andy Williams, Sandra Dee, Maurice Chevalier.
- Tuesday, January 13th - "INTERLUDE" - Starring June Allyson, Rossano Brazzi.
- Tuesday, January 20th - "A VERY SPECIAL FAVOR" - Rock Hudson, Charles Boyer, Leslie Caron.
- Tuesday, January 27th - "TAMMY & THE BACHELOR" - Debbie Reynolds, Leslie Nielsen.

SUN CITY COMMUNITY ASSOCIATION

BULLETIN

VOL. 4, No. 2

February 1, 1970

THE DEL E. WEBB TENTH ANNIVERSARY CELEBRATION WAS A TREMENDOUS SUCCESS, THANKS TO THEIR OWN EFFORTS AND TO ALL THE WONDERFUL PEOPLE HERE IN SUN CITY, WHO HELPED MAKE IT SO.

The officers of the SUN CITY COMMUNITY ASSOCIATION for the year 1970 are:-

Paul W. Waltz, President; Douglas V. Lowther, Vice-President; Audrey N. Bock, Secretary; Kenneth A. Pearce, Treasurer; John W. Prather, Budget-Finance; Carl H. Anderson, Properties; George A. Shuck, Club Organization; Kenneth O. Marion, Committee on Committees; Gordon Evans, Public Relations-Publicity; and Jay S. M. Titus, Manager.

The various committee members will be announced next month.

SUN CITY SPORTSMEN'S CLUB - Were you at the last meeting? We had a splendid turnout. From all reports, they liked what they saw and heard, as many became new members. This automatically made their wives Associate Members. Dues are \$5.00 per year, which includes affiliation with Arizona Wildlife Federation and the National Wildlife Federation. You also receive the state newspaper published monthly. Mr. Jack Mantle, member of the Arizona Game & Fish Commission showed slides of his 1969 African Safari, and his lively comments on his experiences were enlightening and entertaining. How about joining us at our next meeting to hear Bill Younkers' stories and slides on Alaska. Some of his bear hunting stories will raise the hair on your head (if you have any.) Come and visit with us and see if you would like to join the Club. Ladies! If the old man wants to act like one, leave him home - come down and join our group. (He'll follow) There's something for everyone from Big Game Hunting to Bird Watching. Town Hall Center, Room B, February 16, 9:30 AM. Refreshments will be served.

FRIENDS OF THE LIBRARY - Miss Dorothy Weber will present the program for the meeting at 1:30 PM February 2nd in Town Hall Center auditorium. Miss Weber, formerly Assistant Librarian at the Central Public Library in Chicago, has been a volunteer worker in the Sun City library since 1965, and head librarian since Mrs. Mildner's resignation last year. She will talk on current books, many of which have been recently added to the library. She will also bring an exhibit of books purchased from the generous contributions of the Rotary Club over the past years. All meetings are open to the public. For information, please phone Mrs. Mildred Britton, 933-4985.

* DON'T BE A LITTER BUG - *
* EVERY LITTER BIT HURTS; *
* Let us Keep Sun City Homes, *
* Streets and all Facilities *
* CLEAN *

SUN CITY MEN'S CLUB - Meets in Town Hall North club rooms, 12:00 Noon to 5:00 PM daily except Sundays and Holidays. Lunch served at 11:00 AM Saturdays. Next golf tournament February 9th, South Course. Best nine, full handicap. Sign up for starting time, either North or South Course by Wednesday, Feb. 4th. If 1970 dues have not yet been paid, \$2.00 may be mailed to P. O. Box 519. February Bingo parties, Town Hall Center, 7:30 PM, Wednesday, Feb. 11th and 25th. Admittance limited to Community Association Activity Card holders and house guests.

SUN CITY CONTINENTAL DANCE CLUB - will have LIVE music at their dance on February 11th, starting at 8:00 PM. At that time, and also at the Feb. 28th Danco, 1970 dues of \$2.00 per couple will be collected. Please have your 1970 Sun City Community Association Activity Card with you. We meet the 2nd and 4th Wednesday from 8:00 to 9:30 PM at Town Hall South.

ROSE & GARDEN CLUB - Talk and demonstrations on Citrus growing by Mr. Louis Whitworth, Professional Citrus Consultant and a member of the Board of the Arizona Citrus Growers Association. Time and Date - 7:30 PM February 9th, Town Hall Center.

STITCH & KNIT - All those interested in such a club at Lakeview Center, please meet in the sewing room at Lakeview Center, Wednesday, February 4th, 1:30 PM.

- STOP WORRYING -
YOU WILL NEVER GET OUT OF THIS WORLD
ALIVE !

* ARE YOUR 1970 DUES PAID? If *
* not, the Town Hall Center office *
* is open daily Monday thru Friday *
* for your convenience - 9:00 AM *
* to 5:00 PM. Is there anyplace *
* in the whole wide world that you *
* can get as many recreational *
* facilities for \$20.00 per person *
* as here in Sun City? *

NOTICE TO ALL CLUBS

2/24 - 1400
 Mr. GEORGE

PLEASE HAVE YOUR CLUB INFORMATION FOR THE BULLETIN IN BY THE 20TH OF EACH MONTH.

PLEASE HAVE INFORMATION FOR THE TOWN HALL CALENDAR IN THE OFFICE ON OR BEFORE THE 15TH DAY OF THE PRECEDING MONTH. THE HEAVY SCHEDULE ON ALL FACILITIES REQUIRES MORE TIME IN THE ALLOCATION OF SPACE AND PREPARATION OF THE CALENDAR. PLEASE SEND TO ATTENTION OF RILL ABRISCH.

MOVIES MOVIES MOVIES MOVIES MOVIES
TOWN HALL SOUTH AUDITORIUM - TUESDAYS - 7:30 PM

- February 3rd - "THE LIVING DESERT" - A triumphantly beautiful search into the true meaning of the great American desert.

- February 10th - "GYPSY" - Starring Rosalind Russell, Natalie Wood, Karl Malden, Paul Wallace, Betty Bruce. Based on the Broadway hit by Arthur Laurents and the memoirs of Gypsy Rose Lee. 14 great songs and in Technicolor.

- February 17th - "THE GREAT RACE" - Starring Jack Lemmon, Tony Curtis, Natalie Wood, Peter Falk, and other great stars. An automobile race from New York to Paris gets under way with two rivals vying for the affections of a pretty reporter (Natalie Wood).

- February 24th - "THE TROUBLE WITH ANGELS" - Starring Rosalind Russell, Hayley Mills, Binnie Barnes, Gypsy Rose Lee, June Harding, and others. These two new students at St. Francis Academy are happy hellions in constant conflict with Mother Superior.

* * * * *

* ON THE LIGHTER SIDE ! *

* A fellow said: "I think I'll run *
 * for Congress." His friend replied: *

* "I wouldn't vote for you if you were *
 * St. Peter." The first man responded: *

* "If I were St. Peter, you couldn't *
 * vote for me because you wouldn't be *
 * in my district." *

* * * * *

BILLIARDS SCHEDULE ANNOUNCED !

Because of the interest shown in billiards by the ladies, the entire day of Wednesday has been reserved for the fair sex ONLY at the new Lakeview Center. The Billiard Room will be open from 9:00 AM to 5:00 PM. Men will be permitted to instruct the ladies or observe their progress as they participate.

On Friday, the Billiard Room is reserved the same hours for MEN ONLY, with the ladies permitted to observe the various billiard techniques.

On Monday, Tuesday, Thursday and Saturday, the billiard room is open to BOTH men and women from 9:00 AM to 5:00 PM.

ALL CENTERS ARE OPEN TO SUN CITY COMMUNITY ASSOCIATION MEMBERS !

Due to a misunderstanding by many Sun City residents, the following announcement is made covering all facilities at the three Town Hall Centers, as well as the new Lakeview Center:

THESE FACILITIES ARE AVAILABLE TO ALL SUN CITY RESIDENTS WHO ARE MEMBERS OF THE SUN CITY COMMUNITY ASSOCIATION, REGARDLESS OF WHERE THEY LIVE IN SUN CITY.



Sun City Community Association

BULLETIN



VOL. 4, No. 3

March 1, 1970

GREETINGS TO ALL OF OUR NEW MEMBERS AND OLD. WE HOPE YOU WILL FIND OUR BULLETIN INTERESTING AND INFORMATIVE.

RHYTHM & GYM CLUB of Town Hall Center will have its annual spring party on March 30, at 9:00 AM, at Town Hall Center. A variety of entertainment will be provided by members of the club. Refreshments will be served.

SUN CITY ROSE & GARDEN CLUB

Dr. Elizabeth Rearick and Miss Cari Spencer, Sun Citians, will present a slide show entitled "High Country Odyssey" consisting of mountain scenes and wildflowers at the March 9th meeting, 7:30 PM, Town Hall Center auditorium. On March 18, the club will sponsor a desert-card party from 1:00 PM to 3:30 PM at Town Hall Center auditorium. You can play the game of your choice and players are urged to bring their own cards. Proceeds will go toward payment of expenses of the annual Rose Show to be held October 24 and 25. Tickets may be had by calling Miss Edna Volkman, 933-2367, or tickets may be purchased at the door.

FRIENDS OF THE LIBRARY

Mr. Richard B. Goldberg will review Nicholas and Alexander, by Robert K. Massie, at the next regular meeting, Town Hall Center auditorium, Monday, March 2, at 1:30 PM. Mr. Goldberg has been a member of the Phoenix College Social Science Dept. since 1964, specializing in English history, and has taught English history on television.

SUN CITY SPORTSMEN'S CLUB

Another excellent meeting was had on Feb. 16. During the business part of the meeting, information was passed on to the membership about the Javelina Hunt coming up. Of the 120 people attending the meeting, 18 were women who discovered how interesting the Sportsmen's Club meetings can be. At the March 16th meeting, the guest speaker will be Dr. Paul H. Jarrett, who will give a timely dissertation on "snake bite" and what to do about it. There will be NO snakes at the meeting but Dr. Jarrett will show slides of snake bite and how to treat it. Anyone planning a trip through the desert or forest this spring or summer would do well to attend for this information.

ATTENTION LAKEVIEW MALE RESIDENTS

Are you tired of loafing? Would you like to meet new people and make new friends each week? Are you interested in keeping occupied from 20 to 25 hours a week, with pay?

Then get an application from the Lakeview office for a position as monitor at the swim or therapy pools in the new Lakeview recreation complex. Do it today while openings are still available.

ATTENTION LAWN BOWLERS

Plans for the Arizona State Lawn Bowlers championship are completed. Play begins March 2nd and continues thru March 14th. Play will be at the Town Hall South green on Monday, Wednesday and Friday at 10:00 AM and 1:30 PM. Then on Tuesday, Thursday and Saturday, play will be at the same time at the Lakeview Center green. Spectators are welcome, but are requested not to occupy more than two seats on any bench of the playing end.

SUNSHINE SERVICE, INC., OF SUN CITY - will celebrate its 9th Anniversary on March 14th. All members are invited to attend open house at the Sunshine Service Bldg., 10307 Coggins Drive, in Sun City, on Saturday, March 14, between 10:00 AM and 4:00 PM. Our organization has come a long way since its modest beginning and sincere thanks is extended to all Sun Citians for the help they have given over the years. See you on March 14!

WOMAN'S LEAGUE - The Men's Chorus and the Handbell Ringers of Sun City will present a program for the Woman's League at 10:00 AM, March 19th, in Town Hall South. New officers for 1970-71 will be elected during the business meeting. Mrs. MacLeod Coan and Mrs. J. Warner are in charge of hostesses.

SUN CITY MEN'S CLUB meeting in Town Hall North club rooms 12:00 Noon to 5:00 PM daily except Sundays & Holidays. Lunch served at 11:00 AM Saturdays. Next golf tournament, Monday, March 9, north course. Medal Play - Full Handicap. Sign up for starting time, either North or South course by Wednesday, March 4th. March Bingo Parties, Town Hall Center, 7:30 PM Wednesday, March 11th and 25th. Community Association activity card holders and house guests are cordially invited. Bus trips to outstanding big league baseball games will be planned if sufficient interest is shown. These trips last year were a lot of fun. Get your name on the list NOW by phoning 933-9974. You will then be contacted later with complete information as to dates, cost, etc. The ladies are most welcome, naturally.

SUN CITY WEAVERS GUILD - meets each Monday at 10:00 AM, in Craft Room, Lakeview Center. March 2 - Reading of By-Laws -- Weaving. March 9 - Vote on Constitution and Officers - Weaving. March 16, 23, and 30 -- Weaving. Anyone with weaving equipment or weaving books to donate, loan or sell - please let the Weaving Guild know.

MOVIESMOVIESMOVIESMOVIESMOVIESTOWN HALL SOUTH AUDITORIUM - TUESDAYS - 7:30 PM

- March 3rd - "THE MATING GAME" - Starring Debbie Reynolds, Tony Randall, Paul Douglas. A light-hearted spoof about a farmer who operates on a barter economy and has never paid taxes.
- March 10th - "BYE BYE BIRDIE" - Janet Leigh, Dick Van Dyke, Ed Sullivan, John Daly. The freshest, funniest, fastest film musical in years. A zestful show which pokes gentle fun at the younger generation.
- March 24th - "OCEAN'S 11" - Frank Sinatra, Dean Martin, Sammy Davis, Jr., Peter Lawford, Joey Bishop, and others. Guest stars Red Skelton and George Raft. An assorted group of men are called together for a hold-up of five Las Vegas gambling casinos on New Year's Eve.

SUN CITY WOMAN'S CHORUS - will present a musical program at the meeting of the P.E.O. to be held on Monday, March 16th, at 9:30 AM in Town Hall North. Jo Gerig is chorus director, and Dorothy Giebelstein accompanist.

SUN CITY ORGAN CLUB - will meet Wednesday, March 14th, at 7:30 PM, at Town Hall South. Guest organist will be Frank Grenger, Baldwin Organ Distributor of Phoenix. Mrs. Richard Shreve and Mrs. E. Schilling will also give a program of organ music.

SUN CITY COMMUNITY ASSOCIATION - OFFICERS AND COMMITTEE MEMBERS FOR 1970:

Paul W. Waltz, President; Douglas V. Lowther, Vice-President; Audrey N. Bock, Secretary; Kenneth A. Pearce, Treasurer; John W. Prather, Budget-Finance; Carl H. Anderson, Properties; George A. Shuck, Club Organization; Kenneth O. Marion, Committee on Committees; Gordon Evans, Public Relations-Publicity; and Jay S. M. Titus, Manager.

PROPERTIES COMMITTEE

Carl H. Anderson, Chairman	933-6531
Geo. C. Wilson, Vice-Chairman	5023
Wm. J. McDonnal, Member	3672
Kenneth O. Marion	" 7539
Walter F. Schott	" 5777
Frank C. Joseph	" 4249
Daniel Cherry	" 7375
Jack H. Newsom	" 5648
Al Thomas-Moore	" 6865
Harmon Kopperud	" 4415
Edward Frey	" 7546
Vernon H. Peterson	" 3381
Phillip M. Snyder	" 5949
Thomas F. Forrest	" 4069
Otis Brown	" 4451
Edwin L. Forest	" 0460
A. LaMonte Loucks, Alt. Member	1976
John Hellweg	" " 0226
Lowell Petersen	" " 4875

BUDGET-FINANCE

John W. Prather, Chairman	933-4485
Kenneth A. Pearce, Co-Chairman	4518
George Carter	5190
Byron Duncan	0506
William R. Loffer	6751

COMMITTEE ON COMMITTEES

Ken Marion, Chairman	933-7539
Geo. A. Shuck, Vice-Chairman	8404
Mrs. Bertha M. Cox	2660
Mrs. Audrey N. Bock	2145
Douglas V. Lowther	7752
Paul Albert	1698

TREASURER

Kenneth A. Pearce	933-4518
John W. Prather, Ass't. Treasurer	4485

PUBLICITY-PUBLIC RELATIONS

Gordon Evans, Chairman	933-4593
Lloyd Wheadon	4277
Edward H. Roos	2410

CLUB ORGANIZATION

George A. Shuck, Chairman	933-8404
Prime Bartley, Vice-Chairman	2696
Mrs. Ida Mae Schwartz	0919
George Eiker	0344
Mrs. Walter Aebischer	2979
Grant Conner	5630
Leo Yort	3512
Elbert Bushnell	7433

"GOOD HEAVENS," SAID THE SWEET
YOUNG GIRL, "70 ISN'T OLD FOR A
MILLIONAIRE !"

A LOT OF DESIRES ARE NIPPED IN THE
BUDGET.



Sun City Community Association

BULLETIN



VOL. 4, No. 4

April 1, 1970

FRIENDS OF THE LIBRARY - In celebration of LIBRARY WEEK in April, we will have open house on Monday, April 6th, at 1:30 PM, Town Hall Center Auditorium. Mrs. Elaine Rice, English instructor at Phoenix College, will review the book "Mr. Sammler's Planet" by Saul Bellow. Miss Dorothy Weber, Sun City Librarian, will display books recently acquired by the library. Following the program, refreshments will be served and guests are invited to browse in the library.

WOMEN'S LEAGUE - The Rev. Dr. Culver Nelson will present a book review at the April 16th meeting, Town Hall South, at 10:00 AM. Mrs. Berlin Henderson and Mrs. Hubert James will be in charge.

SUN CITY SPORTSMEN'S CLUB - At the March 16th meeting of the Sun City Sportsmen's Club, 125 members and guests heard a lecture and saw slides on what to do and what not to do for snake bite. The guest speaker was Dr. Paul B. Jarrett, a Phoenix physician and surgeon, who has made an extensive study of snake bite. This was a timely lecture because the snake season starts in April, peaks in July, and tapers off in September.

The next meeting of the Sportsmen's Club will be Monday, April 20th, 9:30 AM, at Town Hall Center, Clubroom B. The guest speaker will be Bob Hirsch of KTAR-TV Channel 12. Mr. Hirsch is Editor of the Arizona Sportsmen's News Magazine. His talk will be on fishing in Arizona. Everyone is invited to attend.

A picnic will be sponsored by the Sun City Sportsmen's Club April 10th at a beautiful site on the West side of Lake Pleasant. Take the Dirty Shirt turnoff and follow the signs put up by the club to lead you to the picnic site. This is a brand new place so those wishing to attend should bring their own chairs, card tables, food and drinks. There will be boats for rides and fishing from the boats or bank. Bring your friends and neighbors.

A clean-up campaign will be sponsored by the Sportsmen's Club in April - the tentative date is April 23rd.

Come join us at the picnic April 10th and attend our meeting April 20th. Everyone is welcome.

SUN CITY WOMEN'S CHORUS-HAND BELL RINGERS - Will present a spring Concert, Town Hall South Sunday evening, April 12, at 8:00 PM. No tickets will be sold but a contribution of 1.00 per person will be received at the door. Part of the proceeds will help furnish the chapel of Boswell Memorial Hospital. Gerig is Director for both, and Dorothy Heibelstein is accompanist for the chorus. In APRIL 1st, the Chorus will have a luncheon at SIR GEORGE'S BUFFET at 11:30 AM, followed by cards at Town Hall Center. The Women's Chorus has been invited to sing at the State convention of National Federation of Music Clubs April 25th at Travelodge in Phoenix.

SUN CITY ROSE & GARDEN CLUB - The April 13 meeting of the Sun City Rose & Garden Club will be held at 7:30 PM in Social Hall #3, Lakeview Center. Mr. Lowell True, Maricopa County Agricultural Agent, will give an illustrated lecture on the care of lawns, gardens and flowers in Sun City. Residents of Phase II are invited to attend this meeting to hear Mr. True and become acquainted with the purpose of the Club and the members. Every one be sure to bring your roses for our monthly specimen Rose Show.

SUN CITY ORGAN CLUB - will meet Wednesday, April 15th at 7:30 PM, at Town Hall South. Mrs. Robert Cory, Mrs. Clifford Finley, Miss Mary Jordan, Mrs. Leslie Myers, Mrs. Melvin Shikes and Carl Williams will give the program. Refreshments will be served.

TRAVEL TRAILER CLUB IMPORTANT NOTICE TO MEMBERS

Please be advised that the "COMPOUND AREA" is to be moved to a new location - west of the Sunland Memorial Park. It is anticipated that the move will be in the next 90 days. All users of the facility will be advised in ample time to move their equipment, and it shall be the responsibility of the equipment owners to either personally perform the move or make advance arrangements for others to move their equipment. The Club will not assume the responsibility of moving your equipment. Those who will be away from Sun City during and after the final move, shall contact the compound manager upon return to learn their new space number. ANY EQUIPMENT LEFT IN THE OLD COMPOUND AREA AFTER THE FINAL DATE OF OCCUPANCY SHALL BE DISPOSED OF AS JUNK. As the move progresses, details and schedules will be made available to all.

SUN CITY MEN'S CLUB - meeting in Town Hall North Club Rooms 12 Noon to 5:00 PM daily except Sundays and Holidays. Lunch served at 11:00 AM Saturdays. Next golf tournament Monday, April 13, South Course - best ball two-some; full handicap. Sign up at either North or South course. Sign up early as available times are taken quickly. April BINGO parties, Town Hall Center, 7:30 PM April 8th and 22nd. Community Association Card Holders and their house guests are cordially invited. The Men's Club is the most popular of all chartered clubs in Sun City. If you are a male resident and have a 1970 Activity Card, it costs only \$2.00 per year to belong. In addition to our monthly golf tournaments, you may enjoy the good fellowship of other members who meet daily. Also, an annual event, in itself worth more than the yearly dues, is the MOTHER'S DAY PANCAKE BREAKFAST. This year it will be on Saturday, May 9th, in

MEN'S CLUB (continued)

WANT TO LOSE WEIGHT?

Town Hall Center Auditorium. All Men's Club members and their wives are served a complete breakfast - fruit juice, pancakes, bacon, coffee, etc., as guests of the club. Men, if you are not already a member, you should immediately investigate the benefits of becoming one.

Sun Citizens who are overweight will be glad to know that a new Weight Watchers Club has been formed. It is for both men and women and meets each Tuesday evening at 7:30 PM in the exercise room of Town Hall South. Come and find out about the diet that really works.

THE SUN CITY PLAYERS are presenting a delightful 2-Act Comedy, "SUSAN SLEPT HERE", at Town Hall South on Monday, April 6th and Tuesday, April 7th. The action takes place in Pacific Palisades, Los Angeles, when a Hollywood writer, bachelor Joe Norton, played by J. George Bender, through no act on his part, is presented with a Christmas present in the person of a 17 year old delinquent, Susan Landis, played by Lois Moulton. Ralph Gump, as Sergeant Hanlon, and Don Stewart, as Sergeant Maizel, are detectives who decide that Joe needs Susan for research material. Ken O'Blenes, as Virgil, Joe's commanding officer; Gertrude Pryor as Georgette, Joe's maid; Helen Hilden as Maud, Joe's secretary; and Judith Ann Trevillion as Isabella, Joe's Girl.

MOVIES

MOVIES

MOVIES

MOVIES

MOVIES

TOWN HALL SOUTH AUDITORIUM - TUESDAYS - 7:30 PM

APRIL 14th - "A STORM CALLED MARIA" and "VANISHING PRAIRIE"

- "A Storm called Maria" based on the best seller "STORM", by George Stewart. This unique pictorial biography of one titanic hurricane becomes a drama as suspenseful as any fictional thriller. "Vanishing Prairie" relates the story of THE GREAT AMERICAN PRAIRIE, the vanishing wildlife of the American scene, bringing intimate stories of birds and animals now almost extinct.

APRIL 21st - "BRIGHTY OF THE GRAND CANYON"

- Starring Joseph Cotten, Pat Conway, Dick Foran, Dandy Curran, Karl Swensen, as Theodore Roosevelt and "Brighty", the donkey. "Brighty" is the wonderful story of the shaggy little burro with a natural instinct for discerning good and bad in human beings, a mountain lion hunter, an old prospector, and a boy, all of whom lived in and around the Grand Canyon.

APRIL 28th - "MOVE OVER, DARLING"

- Starring Doris Day, James Garner, Polly Bergen, Chuck Connors, Thelma Ritter and Don Knotts. A Remake of a hilarious comedy of the late 1930's - My Favorite Wife - retains all the fun of the original.

* * * * *

* * * * *

What this world really needs is a computer that can figure out all the things in life that don't add up.

"I understand you're a TV producer," said the lady. "What shows are you to blame for?"



Sun City Community Association

BULLETIN



Vol. 4, No. 5

May 1, 1970

HEAR YE, HEAR YE, ATTENTION ALL SUN CITY RESIDENTS

The next regular quarterly meeting of the Sun City Community Association Corporation will be held MONDAY, MAY 11, 1970, at 1:30 PM, AT TOWN HALL SOUTH.

Please be sure to mark your calendars and plan to attend this very important meeting. There will be a very comprehensive report given by Mr. Paul Waltz, your president, and all of the members of the board. Mr. Jay Titus, your very able manager, will give his report for the past quarter.

There will be a question and answer period. This is the time for all Sun Citizens to find out about the activities that are taking place within the Association.

The Board of Directors welcome and urge each of you to attend so that you may be heard from. We will welcome any constructive ideas to make your Association a better one. SO, PLEASE DO COME.

I would ask the Chairmen of all the Sun City clubs to remind their members of this meeting and to urge them to attend.

Gordon Evans, Chairman
Public Relations

SUN CITY SPORTSMEN'S CLUB

At the April 20th meeting of the Sun City Sportsmen's Club, members and guests heard Bob Hirsch of Channel 12, KTAR-TV, tell about the best places to fish in Arizona. Newcomers to Arizona were amazed at the information of the many lakes and streams to be fished. Bob Hirsch is editor of the magazine, Arizona Wildlife Sportsman, and is happy to share his knowledge of fishing in Arizona with everyone.

The next meeting of the Sportsmen's Club will be Monday, May 18, 9:30 AM, Town Hall Center, Clubroom B. The guest speaker will be James Sparks, manager of the White Mountain Recreation Enterprise. He will lecture on the Apache Indian Reservation at White River, Ariz., and show films on Indian activities. Everyone is invited to come and learn about the recreational features of the Apache Indian Reservation - home sites and Hawley Lake trailer sites. For fishermen, there will be literature on fishing near Show Low and Pinetop; for hunters there will be brochures on Elk, Antelope, Bear and Lion. This should be one of the outstanding lectures of the year. You are in Indian Country - so shouldn't you learn something about your new environment?

Mark your calendar for May 18th and join us for fun and information. Bring your friends, and that includes your lady.

FASHION SHOW - Mark your calendar - Wednesday May 6th, 10:00 AM. This is the date for the Fashion Show sponsored by the Stitch & Knit Club and the Sew 'N Sew Club, to be held around the pool at LAKEVIEW CENTER. Dresses, suits, swim suits, play clothes and accessories made by Sun City Ladies will be modeled. Music by the Rhythm Ramblers. Don't forget the date. MEN ARE WELCOME.

LAKEVIEW CLAY CLUB

Activities have been going strong at our Clay Club, with classes in decorating greenware, casting, and freeform work. Anyone interested in wheel work would enjoy the wheel provided. This wheel is the very latest in this type of equipment.

The next business meeting will be on May 7th at 1:00 PM. This will be the last meeting until Sept. 3rd. There will be no program in May but the business meeting will be followed by a general Ceramic workshop for those interested, and also for the freeform group.

Mark May 7th on your calendar and bring your work. Happy Ceramic-ing.

ORGAN CLUB

The Organ Club will meet May 6th at 7:30PM at Town Hall South. This will be the last meeting until September. The program will be given by Mrs. Stephen Fulmer and Mr. Lee A. Donnell. Mrs. Fulmer will give a musical travelog. Mr. Lee A. Donnell, of Gavetts Piano & Organ Salon of Phoenix, will play on E-3 Model Yamaha Organ.

There will be a social hour after the program. Please come.

FRIENDS OF THE LIBRARY - Will present Mr. M. Peter Overson, head of the Theater Arts Dept., Glendale College, as the speaker at their last regular meeting of the season, Monday, May 4th, 1:30 PM, Town Hall Center Auditorium. His topic will be "The Trend of the Theater and of the Musical Theater Today". Mr. Overson directs plays at G.C.C. and is house manager at Palace West. He spent four years in New York studying, acting, and directing. All are welcome.

HOW ABOUT A PAT ON THE BACK FOR MR. JACK JACKLEY AND HIS STAFF * * * * *

Since April 1st, the four SCCA swim pools have been in full operation seven days a week on a 10:00 AM to 6:00 PM schedule. The three therapy pools are open 10:00 AM to 6:00 PM Monday thru Friday; 10:00 AM to 5:00 PM on Saturdays; closed on Sundays. Jay Titus, SCCA Manager, is gratified by the periodic inspection reports from Maricopa County Health Dept. officials on the excellent condition of all SCCA pools and shower rooms. Says Titus, "There are no pools in the entire county that excell our own in cleanliness and inpurity of water, and this includes those at the luxury resort hotels." Full credit must be given to our pools supervisor, Jack Jackley, and his staff of dedicated monitors who start the day at 6:00 AM in order to be ready for the 10 o'clock opening.

Total attendance at all pools is now running over 500 per day and is expected to increase to well over 1,000 during the summer months. This makes the pools by far the most used facility in Sun City. We appreciate your fine work, fellows.

ON MOTHER'S DAY
By Robert W. Norris

Could I but write to Mother
In that home so far away
And say how much I think of her
On this dear Mother's day.
Of the lessons that she taught me
As I knelt down by her knee,
The man that in the future years
She hoped that I would be.

The passing years cannot erase,
From out my memory,
The vision of her kindly face,
And all she did for me.
So when I think of all these things,
For which I can't repay,
It reminds me of the debt I owe,
On this dear Mother's Day.

TO GRANDMAS

While we're honoring our mothers
With songs and words of praise
While we tell about their kindness
And their tender loving ways
We should like to honor grandmas
They are mothers too, tho old
For they mothered our dear mothers
In the fond memories we hold.

PARODY ON THE STAR SPANGLED BANNER

Oh, say can you see by the dawn's early light
How we sit by de creek for dem fishes to bite,
We is non working poor folks wid nary a care
Cause de goberment send us dat lovely welfare
Dey mails us de momey we don't give back
Dat's why we can drive our new Cadillac
And don't have to work, cause rich folks pay.
Po rich folks must labor from sun to sun
To pay welfare taxes while we has de fun
We don't pay no taxes, we don't rake no goods
Just raise mo' little kids way back in the woods.
Dey pay us to vote and reward us for sin
While dem sweet demmycratics keep de checks comin in.

SUN CITY ROSE & GARDEN CLUB

Will hold a pot luck supper and dance on Monday, May 11th, at 6:00 PM at Town Hall Center Auditorium. Every one is invited to attend with guests and friends. Ladies are to bring a hot dish, salad, or dessert, and the men will bring a one dollar donation.

Anyone expecting to attend, please phone Miss Edna Valkman, 955-2367, and advise her what you will bring. Coffee will be furnished by the Club.

Proceeds will be used towards the expenses of the annual Rose Show which will be held October 24th and 25th. In the past the local Rose Show has been the largest and most outstanding in Arizona.

HELP KEEP SUN CITY BEAUTIFUL.

SUN CITY MEN'S CLUB - meeting in Town Hall North Club Rooms, 12:00 Noon to 5:00 PM daily except Sundays and Holidays. Lunch served at 11:00 AM Saturdays. Next golf tournament Monday, May 11th, North Course - Medal Play, full handicap. Sign up at either North or South Course. Sign up early as available times are taken quickly. May BINGO parties, Town Hall Center, 7:30 PM 13th and 27th. Community Association card holders and their house guests are cordially invited.

The Men's Club is the most popular of all chartered clubs in Sun City. If you are a male resident and have a 1970 Activity Card, it costs only \$2.00 per year to belong. In addition to our monthly golf tournaments, you may enjoy the good fellowship of other members who meet daily. Also, an annual event, in itself worth more than the yearly dues, is the MOTHER'S DAY PANCAKE BREAKFAST. This year it will be on Saturday, May 9th, in Town Hall Center Auditorium. All Men's Club members and their wives are served a complete breakfast - fruit juice, pancakes, bacon, coffee, etc., as guests of the club. Men, if you are not already a member, you should immediately investigate the benefits of becoming one.

* * * * *

LAST BULLETIN UNTIL SEPTEMBER

* * * * *
We take this opportunity to wish each and everyone of you a most pleasant summer, whether it be spent here at home on the desert or in the cool, cool, north country. Best of health, and may the good Lord bless you.



Sun City Community Association

BULLETIN



VOL. 4 No 6

September 1, 1970

ATTENTION ALL SUN CITY RESIDENTS

The next regular quarterly meeting of the Sun City Community Association will be held Monday, September 14, 1970, at 1:30 PM, at Town Hall South.

There will be a discussion of possible amendments to our present By-Laws and a complete report by the Board covering the past three months; also a report by the Manager.

We urge you to attend and bring your neighbors. It is hoped that all Chairmen of the clubs in Sun City will be there and bring their members along.

ADMITTANCE BY MEMBERSHIP CARD ONLY.

Gordon Evans, Chairman
Public Relations

- - -

Mr. George Shuck resigned from the Board for health reasons and was replaced by Mr. R. J. Meinert on August 17, 1970. The Board of Directors wish to thank Mr. Shuck for his very fine work while on the Board and wish him a speedy recovery. It was the feeling of the Board that his replacement should come from Phase II, in order to give them representation - so welcome aboard Mr. R. J. Meinert - you are now Chairman of the Club Organization Committee and we know you will do a good job for the Association.

- - -

IMPORTANT NOTICE TO ALL CLUB OFFICERS

We welcome your news items for the BULLETIN. Please turn them in not later than the 20th of each month. It would help us a great deal if you would type them in single lines and not more than 4 1/2 inches wide. By doing them this way, most of the time they will fit in the space in the Bulletin and we can use them as written. Please contact Mrs. Rill Abrisch, Town Hall Center office, for further information.

- - -

SEWING CLUB - The sewing technique classes taught by Mrs. Raymond Kruke, will begin on Monday, September 21, 1970. In the sewing room at Town Hall Center on Peoria Avenue.

HAND BELL RINGERS OF SUN CITY - Will begin fall practice for experienced Ringers at 9:00 AM Friday, Sept. 18, Club Rooms at Town Hall Center. A meeting for others with musical backgrounds who are interested in ringing will be held on Thursday, Sept. 24, Same Place and Hour. An interesting fall program is planned with two tentative dates for performing in Phoenix as well as a festival of bells for Sun City.

LAKEVIEW LAPIDARY CLUB - The Lapidary Shop is open from 8:00 AM to 4:00 PM. Monthly meetings are held every third Thursday, beginning with Sept. 17th at 1:30 PM. Meetings are held in the crafts room of Lakeview Center. Lapidary instruction takes place every Thursday afternoon from 1:00 to 4:00 PM and will get under way on Sept. 10th.

SUN CITY MEN'S CLUB - Meets at 10725 Oakmont Drive, 12 to 5, Monday thru Friday (except holidays); Saturday 11 to 5, with luncheon served. Membership meeting is scheduled for 12:30 PM Saturday, Sept. 5, to approve changes in Articles of Incorporation.

Bingo dates during September will be Wednesday, Sept. 2nd, 9th, 16th and 23rd. Town Hall Center auditorium will not be available on Sept. 30th. Community Association Activity Card holders and house guests are invited.

Persons interested in making up bus trips to hockey, basketball or Dog Track during the winter months (both members and non-members) should register their names so they may be called when such trips are arranged. No bus to football games - no buses available or satisfactory tickets. Alex Makarov is Director of Special Events. Write him at Box 519, or phone 933-9974. Mr. Owen Childress, Vice-President, Del E. Webb Development Co., has advised that construction of the new addition to Town Hall North will begin the first week in September.

* * *

RHYTHM CLASS - The Tuesday morning Rhythm Class will resume meetings on Sept. 1, 1970 at Town Hall North, 9:00 AM, for three weeks. Beginning Sept. 22, and every Tuesday thereafter, they will meet at 8:30 AM.

I used to like fresh air
When it was there.
And water - I enjoyed it
Til we destroyed it.
Each day the land's diminished,
I think I'm finished.

MOVIES

MOVIES

MOVIES

MOVIES

TOWN HALL SOUTH AUDITORIUM

TUESDAYS

7:30 PM

Sept. 15th - "KISSES FOR MY PRESIDENT"

- For the first time in history, a woman is elected President. Trouble really pyramids for the family - she feels overworked, her husband feels underprivileged, their son becomes a delinquent, and she discovers she is going to have a baby.

Sept. 22nd - "CALL ME MADAM"

- Based on the Leland Hayward stage production, the wonderful musical about an uninhibited Washington hostess who is appointed Ambassador to the grand duchy of "Lichtenburg".

Sept. 29th - "GREEN FIRE"

- Starring Stewart Granger, Grace Kelly, Paul Douglas and John Ericson. A couple of rough-tough mining engineers, by accident, discover a long-forgotten emerald mine. Against the advice of the local priest, they pool their resources to buy equipment to re-open the mine. Complications arise when the mine shaft collapses.

SUN CITY MALE CHORUS - Rehearsals for the 1970-71 musical season of the Sun City Male Chorus will begin on Saturday, Sept. 12, at 8:30 AM in Auditorium "A" of Town Hall Center. This year, as last year, the chorus will be under the very capable leadership of the distinguished director, William Walley.

Preparations are being made for another successful Christmas Concert to be presented together with the Sun City Woman's Chorus on December 13 and 14.

Present members invite new members to come to the first rehearsal on Sept. 12. Men who enjoy singing, who instinctively sing for the love of singing, and who enjoy the sociability and fun engendered by a group of men having like interests, are invited to join the Male Chorus.

SUN CITY WOMAN'S CHORUS - will begin rehearsals on Wednesday, Sept. 9, at 9:30 AM in the Town Hall Center Auditorium. Marion F. Jewell will direct the chorus this year, replacing Jo Gerig who has retired. Mrs. Gerig will remain a member of the chorus and will continue as director of the Handbell Ringers. Mrs. Jewell has been a resident of Sun City and a member of the chorus for the past year and has had considerable experience as a director. Dorothy Giebelstein will again be chorus accompanist. Chorus officers are: Harriet Bush, Chairman, phone 933-6271; Ida Argersinger, Vice-Chmn., 933-6250; and Gladys Queen, Secy-Treas., 933-6035. Women interested in singing three-part music should contact the director, Marion Jewell, 10426 El Capitan Circle, phone 933-9609, or one of the officers.

SUN CITY SPORTSMAN'S CLUB - NOTE CHANGE OF MEETING PLACE. Will meet Monday, Sept. 21, 9:30 AM, at Lakeview Center, Social Hall #3. This change brought about due to the increase in membership and attendance.

Two very interesting films will be shown: "TO HAVE AND TO HARVEST" - Methods used in today's deer management and many shots of deer and other wildlife.

"KAIBAB BUCK" - This film is a bow and arrow hunt in the famous North Kaibab Forest. It takes you through Navajo and Hopi country. Scenery shots reveal typical deer range and some fine Kaibab Deer. Don't forget the date and new meeting place - bring your wife and outdoor friends. Refreshments will be served.

A THOUGHT

You have never lived a "perfect day" even though you have earned your wage, unless you have done something for someone who will never be able to repay you.

"PROMISE YOURSELF"

- To be strong that nothing can disturb your mind.
- To talk health, happiness and prosperity to every person you meet.
- To make all your friends feel that there is something good in them.
- To give so much time to the improvement of yourself that you have no time to criticize others.
- To be too large for worry, too noble for anger, and too happy to permit the presence of trouble.

A man may love a woman even though he hates her cooking, but no man can love a woman's cooking without feeling some sort of tenderness for her.



Sun City Community Association

BULLETIN



Vol. 4, No. 7

October 1, 1970

STELLA S. PRATHER, BELOVED WIFE OF JOHN W. PRATHER, ONE OF OUR DIRECTORS, PASSED AWAY ON SEPTEMBER 15, 1970. OUR SYMPATHY GOES OUT TO JOHN AND HIS FAMILY.

* * * * *

IMPORTANT NOTICE TO ALL CLUBS

IT IS NECESSARY THAT ANY SCHEDULE CHANGES BE GIVEN TO MRS. RILL ABRISCH AT TOWN HALL OFFICE BY THE 15TH OF THE MONTH, IN ORDER TO BE INCORPORATED IN THE NEXT MONTH'S CALENDAR. ANY CHANGES AFTER THE 15TH WILL NOT BE SHOWN ON THE CALENDAR.

* * * * *

SUN CITY ROSE & GARDEN CLUB - Busy days are ahead for the members of the Sun City Rose & Garden Club. On Tuesday, October 6, they will have their fall card party at the Town Hall Center Auditorium from 1:00 PM to 3:30 PM. There will be dessert, table prizes and door prizes. Bring your own cards and play the game of your choice.

On October 9 and 10, they will have a table at the Sun City Merchants Fair, where they will dispense information about roses and gardens in general.

Regular membership meeting will be held on October 12 at 7:30 PM at Town Hall Center Auditorium. Guest speakers will be Mr. & Mrs. James Long of Phoenix who are outstanding Rosarians. This will be the last meeting before the annual Rose Show and anyone wishing information about showing roses is welcome to attend.

The FIFTH ANNUAL ROSE SHOW will be held October 24 and 25 at Town Hall Center Auditorium. Everyone is invited to exhibit their roses. Membership in the Club or the American Rose Society is not required. Specimen roses for the show must be entered before 10:00 AM on October 24. The show will be open to the public on Saturday, Oct. 24, from 2:00 PM to 8:00 PM and on Sunday, October 25, from 10:00 AM to 6:00 PM. Awards will be distributed on Sunday, Oct. 25, at 4:30 PM. Admission is free.

Classes in Flower arrangements will be held Tuesdays, October 13 and 20, at 9:00 AM at the Club Rooms, Peoria Avenue.

FRIENDS OF THE LIBRARY - The first regular meeting of the new season will be held on Monday, October 5th, at 1:30 PM in the Town Hall Center Auditorium. On display will be many of the new books acquired by the library over the summer months, and Miss Dorothy Leber, Head Librarian, of the Sun City Library, will review one of her favorites. The public is cordially invited to all meetings.

SUN CITY CLAY CLUB - Will hold Open House on Sunday, November 1, from 2:00 to 5:00 PM. Members will display their ceramic works of art made since the Club began last January. They will also offer many interesting articles for sale for the benefit of the Club. A cordial invitation is extended to one and all - a good way to get acquainted and to see what can be accomplished in this very popular craft.

Fall activities have already started, with classes for beginners and advanced decorating on Tuesdays, beginning freeform on Wednesday afternoons, and workshops on Wednesday mornings and all day Thursday. A class in intermediate freeform will begin October 16th and new classes for beginners and advanced decorating will begin Oct. 20. There will also be classes on Mondays when a sufficient number enroll. Sign-up sheets are posted on the bulletin board in the club room for those wishing to join classes.

LAKEVIEW CENTER ART CLUB - Will meet Friday, October 2nd, at 1:00 PM. "Introduction to Decoupage" will be given by Mrs. Hershel Palmer, who will show a collection of her work and give a brief introduction to decoupage, both Victorian and Modern. Mrs. Palmer is a newcomer to Sun City from Detroit, Mich. She has taught decoupage for three years and has studied with Marie Mitchell of Detroit and Patricia Nimocks of Louisville, Ky. She is presently teaching at Witch Craft.

SUN CITY ORGAN CLUB - Will meet Wednesday, October 7, at 7:30 PM at Town Hall South. The program will be given by Mrs. George Lovgren, Mrs. Blanche Lesser and Mr. Al Dickey, all members of the club. Membership is open to all Sun City residents.

TOWN HALL LAWN BOWLS CLUB - Will meet on Monday, October 5th, at 3:30 PM, at Town Hall South Auditorium. Nominating Committee will make their report and the time of day for lawn bowling will be given consideration.

* * * * *

Common sense is the knack of seeing things as they are and doing things as they should be.

WEAVERS' GUILD--Monthly meetings are held the first Monday of each month in the craft room at Lakeview Center. Many interesting programs have been planned for the coming season. At the Oct. 5th meeting, Agnes Rominger from Sedona, well known weaver, lecturer and teacher, will give a program on "Color". At the Nov. 5th meeting, there will be an exhibition of hand woven Christmas items, plus an interesting program. Anyone interested in weaving is invited to attend the meetings. Lucia Mysch will give a beginners class in weaving starting in October. Anyone interested, call Vera Cooly 933-8591. The craft room is open each Monday for weavers who wish to work on projects.

SPECIAL NOTICE

Effective October 1st, the usual fall schedule will obtain at all pools - Open 10:00 AM to 6:00 PM, daily and Sundays. There will be no change in therapy pool hours which are 10:00 AM to 6:00 PM daily, Monday through Friday; 10:00 AM to 5:00 PM on Saturday - closed on Sunday.

Mini-Golf, Tennis & Boats will be open from 9:00 AM to 10:00 PM, daily and Sunday.

SUN CITY SPORTSMEN'S CLUB - held their first Fall meeting Monday, Sept. 21. The Fall program proposed for the Club included Auto Emissions Check by Arizona Public Health the last week of September; for October - a display booth at the Country Fair, and a club picnic. A Buffalo Bar-B-Q is planned for November and a Johnny Horizon Clean-up for December.

There were 21 new members and guests at the September meeting. For the information of new Sun City arrivals, the Sportsmen's Club is affiliated with the Arizona Wildlife Federation and the National Wildlife Federation. The wives of male members are associate members, but the Ladies who join the club are non-voting members.

The Club is open to all who have a SCCA Activity Card and are interested in the outdoors, ranging from Bird Watching to Big Game Hunting.

The next meeting of the Club is Monday, October 19, 9:30 AM, at Lakeview Center Social Hall #3, just to the left of the West ramp. Come, attend the meeting as our guest to see if you would like to join us. A Red Cross program in first aid will be given.

SUN CITY MEN'S CLUB - Club rooms, 10725 Oakmont Drive - Meets Monday through Friday, 12 Noon to 5:00 PM; Saturdays 11 to 5, with luncheon served. Membership meeting Saturday, October 10, at 12:30 PM, when candidates for 1971 Board of Directors will be introduced. Bingo dates in October: Wednesday, 14th, 21st, and 28th, Town Hall Center Auditorium. Activity card holders and house guests cordially invited.

The sweetest music we've heard in many a moon is that of carpenters' hammers at work on the new addition. If the progress made to date is any criterion, it should be ready for occupancy within a few weeks.

Unless more interest is shown (by registering names) it is unlikely the Club will sponsor bus trips to various events this fall. If interested, phone 933-9974, so that you may be notified when bus trips are finalized.

<u>MOVIES</u>	<u>MOVIES</u>
<u>TOWN HALL</u>	<u>SOUTH AUDITORIUM</u>

<u>MOVIES</u>	<u>MOVIES</u>
<u>TUESDAYS</u>	<u>7:30 PM</u>

October 6th - "THE MERRY WIDOW"

- Starring LANA TURNER. Based on the operetta by Frank Lehár. A rich American widow is invited back to her husband's birthplace by the king, who needs her money. Disgusted by fortune hunters, she heads to Paris for a good time, pursued by the king's nephew.

October 13th - "TRUE GRIT"

- Starring JOHN WAYNE, GLENN CAMPBELL. A spunky teenager, Kim Darby, determined to avenge her father's murder, enlists the aid of a tough, one-eyed marshall, John Wayne. They are also helped by a young Texas Ranger, Glenn Campbell, in tracking down the same killer for a reward.

October 20th - "GREEN FIRE"

- Starring STEWART GRANGER, GRACE KELLY, PAUL DOUGLAS, AND JOHN ERICSON. A couple of rough-tough mining engineers, by accident, discover a long-forgotten emerald mine. Against the advice of the local priest, they pool their resources to buy equipment to re-open the mine. Complications arise when the mine shaft collapses.

October 27th - "CAT BALLOU"

- Starring JANE FONDA, LEE MARVIN & NAT KING COLE. "Cat Ballou" is a classic kooky American comedy. Lee Marvin won an academy award as best actor of the year for his performance as the drunkest gun fighter in the West. Nat King Cole sings "The Ballad of Cat Ballou", providing an amusing musical commentary.

* * * * *

Form Good Habits. They're as hard to break as bad ones.



Sun City Community Association

BULLETIN



Vol. 4, No. 9

December 1, 1970

IMPORTANT

IMPORTANT

IMPORTANT

ANNUAL ELECTION TO THE BOARD OF DIRECTORS

DATE: Thursday, December 3, 1970
TIME: 10:00 AM to 6:00 PM
PLACE: TOWN HALL SOUTH AUDITORIUM

Mark your calendar NOW! Come out and VOTE! Be an active PARTICIPANT, not a spectator. Elect and support your Sun City Community Association Board of Directors for continued progressive and efficient management of the myriad of complex problems faced in the operation of the facilities for all members in this beautiful city. Remember Civic Pride is the only remuneration received by any board member.

NOTE: BRING YOUR CURRENT ASSOCIATION MEMBERSHIP CARD TO VOTE

FIVE DIRECTORS TO BE ELECTED

You may vote by absentee ballot until November 30th if ill or out of Maricopa County on December 3rd.

NOTICE: A SPECIAL ELECTION NEWS BROCHURE HAS BEEN PREPARED AND IS AVAILABLE AT ALL TOWN HALLS, IN THE BUSINESS OFFICE, AND FROM CLUB CHAIRMEN.

THE BOARD OF DIRECTORS AND STAFF OF THE SUN CITY COMMUNITY ASSOCIATION WISHES TO EXTEND TO ALL RESIDENTS AND ASSOCIATES A VERY MERRY CHRISTMAS AND A HAPPY NEW YEAR. MAY YOU HAVE A JOYOUS YULETIDE SEASON WITH PEACE, HARMONY AND LOVE OF YOUR FELLOW MAN PREVAILING.

NOTICE TO ALL CLUBS

PLEASE INFORM THE OFFICE, AS SOON AS POSSIBLE AFTER YOUR ANNUAL ELECTION, THE NAMES, ADDRESSES AND TELEPHONE NUMBERS OF YOUR 1971 OFFICERS, FOR NEW CLUB LIST WHICH WILL BE ISSUED JANUARY 15.

SUN CITY ROSE & GARDEN CLUB - will have its annual Christmas party on Monday, Dec. 14, at 6:30 PM, at Town Hall Center Auditorium.

The Club will furnish Baked Ham and Turkey and the Ladies are to bring potatoes, vegetables, salads, desserts, or whatever else they consider should go with a Christmas Dinner, sufficient for 6 to 8 servings. The men will be charged \$1.00 each. BE SURE TO BRING YOUR OWN TABLE SERVICE. EVERYONE is welcome - whether a member of the club or not. Ladies, will you please advise Miss Edna Volkman, phone 933-2367, or write 9433 - 111th Avenue, what you plan to bring.

ORGAN CLUB - will meet at Town Hall South Wednesday, December 2nd, at 7:30 PM.

Officers for the coming year will be elected. The guest organist will be Bill Dutcher. Mr. Dutcher began his professional career with Horace Heidt and has played for Radio and TV. His program will feature Christmas music, old familiar numbers and popular songs of the day. A social hour will follow the program.

MEN'S CLUB - Meets daily Monday thru Friday in the Club rooms, Town Hall North, 12:00 to 5:00 PM; Saturday 11:00 to 5:00 PM, with luncheon served at 11:00 AM. LATEST PROJECT: To supply meats for baskets to be distributed for Christmas to needy families in El Mirage and Peoria. Donations may be either money or canned meats. It is hoped enough money is received so poultry or a ham may be included in each basket. Checks made payable to "MEN'S CLUB, NEEDY FUND" should be mailed to Box 519, Sun City, or turned in at the Club rooms. December "Games Nite" in Town Hall Center Auditorium will be on December 9th and 23rd ONLY, due to unavailability of auditorium on other Wednesday nights.

FRIENDS OF THE LIBRARY - For the Christmas program, Mrs. Mary Ann Dutton, Music Professor of Glendale College, will present in costume the Chamber Singers, 20 students of the Music Dept., in Madrigals and Christmas Music, a capella. Meeting will begin at 2:00 PM Monday, Dec. 7, in THC Auditorium. Please note later time. The AARP will

(over)

FRIENDS OF THE LIBRARY (continued)
 meet with us for the musical program and
 will be co-hosts for the tea following.
 Coffee, punch, and cookies will be served.

SUN CITY WOMAN'S CHORUS and the SUN CITY
 MALE CHORUS - will present a Christmas con-
 cert at Town Hall South Auditorium on Sunday
 December 13th, and Monday, December 14th,
 at 8:00 PM.

The combined choruses number over 100
 voices. The Woman's Chorus is directed by
 Marion Jewell with Dorothy Giebelstein as
 the accompanist. The Male Chorus is
 directed by Willis Walley, with Esther Weiss
 and Elizabeth Clifton as the accompanists.

The concert will again consist of an
 interesting program of numbers by each of
 the choruses and will conclude with Handel's
 Messiah being sung by the combined choruses.

For \$1.00 donations each, tickets may be
 obtained from members of the choruses, and
 will be available at the South auditorium
 on the concert evenings.

SUN CITY SYMPHONY ORCHESTRA - HOLDERS OF
 SEASON TICKETS, PLEASE NOTE:

The concert scheduled for evening of Sun-
 day, December 20, at Town Hall South, will
 start at 8:15 PM, rather than the usual
 8:00 PM. An additional musical treat, in
 keeping with the Season, will precede the
 Symphony Concert. Please note the change
 in time.

FEDERATED WOMAN'S CLUB OF SUN CITY - Founders
 Day Anniversary Tea will be held in Town
 Hall Center on Sunday, Dec. 6th, from 2 to
 4 o'clock. All members are invited, espe-
 cially Charter members. Our State President,
 Mrs. A.W. Spence, and Mrs. Clarence Prather,
 Central Distr. President, will be present;
 also Mrs. Wm. Wade, who helped organize Sun
 City Federated Woman's Club.

SUN CITY SPORTSMEN'S CLUB - An election for
 three new Board members resulted in John
 Anderson, John Doremus and Charles Funden-
 berg being elected to serve for three years
 starting January 1st. The Board of nine
 members will choose the new Chairman for
 1971 at the Board meeting December 7th.

Please note - the Archery Range has been
 moved to Town Hall Center. Archers can use
 it anytime, but those wishing instruction
 or who have never done Archery, but would
 like to try it, John Bogar will instruct
 every Thursday from 9:00 to 10:00 AM.

The Sportsman's Club tries to keep Sun
 City clean by picking up the litter twice
 a year. The 4th litter pickup will be
 December 14, starting at 8:00 AM and will
 last about two hours. At least 40 people
 are needed to help so that our town will be
 clean for Christmas. Anyone who would like
 to help, call either Franklin Rose, 933-7317
 or Harry Kieling, 933-2946, and they will
 assign you to a short section close to home.

Anyone interested in Trap Shooting? Our
 trap shooters use the Peoria Rod & Gun Club
 range every Wednesday at 9:00 AM. For
 further information, call Dr. Earl Blair,
 933-2664.

The next meeting of the Sun City Sports-
 men's Club will be December 21, 9:30 AM,
 at Lakeview Center, Social Hall #3. Bring
 your wife, neighbors, or anyone interested
 in the outdoors. Refreshments served.

FRIENDS OF CHAMBER MUSIC - Last concert of
 the 1970 Season will be Sunday at 3:00 PM
 November 29, 1970, at the United Presbyter-
 ian Church, 103rd & Alabama, with Dr. James
 Barber, violinist; Dr. Gordon Epperson,
 cellist, and Dorothy Beason, lyric Soprano.
 Program will consist of violin and cello
 duo's by Boccherini, Ravel, Kodaly, and
 songs by Bach and Vivaldi.

MOVIES

MOVIES

MOVIES

MOVIES

MOVIES

TOWN HALL SOUTH AUDITORIUM

TUESDAYS

7:30 PM

ORGAN CONCERT AT 7:00 PM - BLANCHE E. LESSER

- December 1st - "MACKENNA'S GOLD" - With Gregory Peck, Keenan Wynn, Lee J. Cobb,
 and others. This is a story of adventure, but
 it is also a story of man's hunger for gold.
- December 8th - "SHOW BOAT" - Starring Ava Gardner, Joe E. Brown, Agnes Moore-
 head and William Warfield. A colorful story
 of a group of entertainers who travelled the
 Mississippi River on a showboat at the turn of
 the century.
- December 15th - "TOBY TYLER" - Starring Kevin Corcoran, Henry Galvin, Gene
 Sheldon and "Mr. Stubbs". A boy, a scene-
 stealing chimpanzee, and a small traveling
 circus at the turn of the century.
- December 22nd - "RHAPSODY IN BLUE" - Joan Leslie, Oscar Levant, Chas. Coburn and
 Julie Bishop. George Gershwin's career, from
 New York's East Side to the Music Hall and
 concert stages of the world.
- December 29th - "BRIGHTY OF THE
 GRAND CANYON" - Starring Joseph Cotton, Pat Conway, Karl Swenson
 as Theodore Roosevelt, and "Brighty", the donkey.
 The story of a shaggy burro with a natural
 instinct for discerning good and bad in human
 beings.

ARTICLE I - OFFICE

The principal office for the transaction of business of Town Hall shall be located in Sun City, Arizona.

ARTICLE II - MEMBERSHIP

SECTION 1. (a) Members shall be homeowners and/or residents occupying a house or apartment which is located as designated in the Articles of Incorporation.

(b) Membership shall not be transferable.

(c) A member must be current in the payment of the annual assessments to validate the membership and to entitle the member to all rights and privileges of same.

SECTION 2. (a) Privileges of members shall be to vote, to hold office, to use all available facilities, subject to the rules and regulations of Town Hall or approved for the chartered clubs, and to participate and become members of all activities and clubs of Town Hall. Members shall have certain guest privileges as provided in the "Rules and Regulations".

(b) No member shall be denied the use of any facilities of Town Hall even though he has no membership in any chartered club, and no chartered club shall have any rule or regulation, except those for the safety of persons and/or protection of property, prohibiting the use of any facility by such member.

(c) No member or group of members, whether or not sponsored by a chartered club, or any other person or persons, shall so conduct themselves in or on Town Hall property as to violate any local, county, state or federal law and/or jeopardize the rights and privileges of other Town Hall members, their guests or any other person or persons. A cease and desist order shall be issued by the Town Hall Board of Directors against such infractions and, upon failure of such infractors to comply with said order, denial of the use of Town Hall property for such practices shall be ordered by the Board.

SECTION 3. (a) The assessments for all members for each fiscal year (January 1 through December 31) shall be determined by the Board of Directors of this Corporation. Such assessments shall be due and payable January 1st of each year. Payment will entitle each member to a card which is valid in all Town Hall facilities. If home ownership should be established during the fiscal year, the assessment shall be prorated on a monthly basis until the end of the current fiscal year.

(b) An admission or re-admission fee of one hundred (100) dollars for application or restoration to membership after a delinquency of six (6) months in the payment of assessments due, or after withdrawal from membership, shall obtain.

SECTION 4. (a) A membership may be suspended or the member expelled by the Board of Directors, after a hearing by the Board, for non-compliance by such member with the provisions of the Articles, By-Laws, Rules and Regulations.

(OVER)

(b) Application for reinstatement may be filed with the Board of Directors after such suspension or expulsion has been effective for thirty (30) days. During the period of suspension or expulsion such member shall have no rights to utilize any of the facilities of Town Hall.

SECTION 5. (a) Regular corporation membership meetings shall be held during the months of January, May, September and November, at a place, date and hour to be set by the Board of Directors.

(b) One hundred (100) members may file a request with the Secretary of the Board of Directors for a special meeting, stating the reasons for the meeting. The President shall call such a special meeting within ten (10) days after receiving such request. A quorum for any meeting shall consist of not less than one hundred (100) members and Roberts' Rules of Order, Revised, shall prevail, except as provided in the By-Laws. A quorum shall be presumed in the absence of a challenge.

ARTICLE III - OFFICERS

SECTION 1. The officers of the Corporation shall be President, Vice-President, Secretary, and Treasurer.

SECTION 2. President. The President shall be Chairman of the Board of Directors and shall preside at and conduct all meetings by a formal order of business. He shall have general supervision and direction of the affairs of the Corporation in accordance with the By-Laws, shall have authority to administer all matters not otherwise expressly delegated, shall appoint all committees (with the consent and approval of the Board) except the Nominating, Balloting and Executive Committees, and shall call all special meetings of the Corporation and/or the Board of Directors.

SECTION 3. Vice-President. The Vice-President shall perform the duties of the President during the latter's absence.

SECTION 4. Secretary. The Secretary shall keep a record of the minutes of the meetings, shall send out notices of meetings and shall keep the members informed by bulletins from time to time as occasion warrants and shall perform such other duties as ordinarily pertain to that office.

SECTION 5. Treasurer. The Treasurer shall be the custodian of all funds of the Corporation and shall collect and disburse the same and keep a financial record thereof as prescribed by the Board of Directors and deposit them in the bank or banks designated by the Board of Directors; shall sign all checks which shall be countersigned by the President or such other officers or Board members as may be designated by the Board of Directors; shall issue financial statements when required and perform such other duties as ordinarily pertain to that office.

SECTION 6. All officers, Board members, Committee chairmen and members, and employees who are in any way involved in the handling of Corporation funds, and the paid manager of

the Corporation, shall be bonded in a sum to be determined by the Board of Directors.

SECTION 7. Term of office. The term of office of all elected officers shall be one year. Elected officers shall serve until their successors are duly elected and installed.

ARTICLE IV - BOARD OF DIRECTORS

SECTION 1. There shall be eleven (11) directors, including the four elected officers, none of whom shall receive a salary for his service to the Corporation.

SECTION 2. The four officers shall be elected annually; the other seven directors shall be elected for two year terms, three of them being elected in odd-numbered years, four in even-numbered years.

SECTION 3. Regular meetings shall be at Town Hall on the first Monday of each month at 9:00 AM, unless otherwise specified by the President, who shall preside at all meetings. Two-thirds of the members shall constitute a quorum. All meetings shall be conducted in accordance with the By-Laws and Roberts' Rules of Order, Revised, except as provided in the By-Laws.

SECTION 4. The Board of Directors shall hold and administer the assets, and shall direct, control, manage, and supervise the business and affairs of the Corporation.

SECTION 5. The Board of Directors shall have authority to make rules and regulations as deemed expedient and to incorporate in the By-Laws such rules and regulations by reference.

ARTICLE V - VACANCIES

SECTION 1. Removal. Action for removal of any elected officer or member of the Board of Directors may be initiated by not less than one hundred (100) members of the Corporation, who shall submit their reasons in writing to the Secretary. The request for recall shall be publicized for not less than twenty-six (26) days, after which and within seven (7) days the members of the Corporation may vote on the recall by secret ballot, according to Article IX of these By-Laws and the Rules and Regulations. Two-thirds of all votes cast at the last annual election in December shall be necessary for the recall of an elected officer or Board member.

SECTION 2. Vacancy. The Board of Directors may declare vacant the position of any officer or director who, without good and sufficient reasons acceptable to the remaining members of the Board, is absent from three or more consecutive regular meetings of the Board.

SECTION 3. Replacement. A vacancy on the Board of Directors or in any office, because of death, resignation, removal, disqualification or otherwise, shall be filled by the Board of Directors, subject to the approval of the members of the Corporation, by appointment of a member of the Corporation to serve until the next annual election. A director appointed to fill a vacancy shall serve for the unexpired term of his predecessor.

COVER

ARTICLE VI - COMMITTEES

SECTION 1. The President shall be empowered to appoint, with the consent and approval of the Board, such committees as he may deem necessary to properly and effectively carry on the affairs of the Corporation. This authority shall include all committees, standing and special, except the Nominating, Balloting, and Executive committees, which are specifically provided for in Articles VIII and IX of these By-Laws and/or the Rules and Regulations.

ARTICLE VII - CHARTERED CLUBS

SECTION 1. A chartered Town Hall club is one approved by the Board of Directors. Requirements for chartering, as well as the duties, responsibilities and authorities of such clubs are outlined in the "Club Organization" section of the Rules and Regulations. There shall be no conflict of club rules and regulations with the Articles of Incorporation and/or the By-Laws, and/or Rules and Regulations of this Corporation.

ARTICLE VIII - NOMINATION PROCEDURE

SECTION 1. The Nominating Committee shall submit a slate of officers and directors for consideration by the Board of Directors, consisting of at least two (2) candidates for each of the offices and director openings in accordance with approved procedure in the Rules and Regulations.

SECTION 2. The slate shall be announced at the regular November meeting of the Corporation and thereafter published and posted.

SECTION 3. The Board of Directors shall set the date and conduct the election in December not later than the 15th of that month.

ARTICLE IX - VOTING PROCEDURE

SECTION 1. Voting on all matters of business, whether by secret ballot or otherwise, shall be in accordance with the procedure as specified in the Rules and Regulations.

ARTICLE X - AMENDMENTS

SECTION 1. (a) Action on changes and/or amendments to the By-Laws may be initiated by the Board of Directors or by petition of at least one hundred (100) members of the Corporation. These By-Laws may be amended, modified or revoked by the Board of Directors or by the members, but such action by the Board shall be subject to approval by vote of the members at the first regular Corporation membership meeting following such Board action.

(b) In cases where the members initiate the action or where the Board submits the matter to a vote before making any changes and/or amendments, the proposed changes and/or amendments shall be given to the Board at least ten (10) days prior to a regularly scheduled meeting of the Corporation, at which meeting the proposed changes and/or amendments shall be read and voted upon.

(c) Voting shall be according to Article IX and the procedure outlined in the Rules and Regulations.

ARTICLE XI - RESTRICTION

SECTION 1. No Article, Section or Sub-section in these By-Laws shall be in conflict with the Articles of Incorporation.

May 8, 1967

May 9, 1967

TO ALL MEMBERS OF SUN CITY TOWN HALL CENTER:

In the January Corporation meeting for Town Hall members, we outlined certain important things we expected to do in 1967. The FIRST AND MOST IMPORTANT was to appoint a special committee to study our entire operation and to recommend such revisions of our By-Laws as will provide a business-like, modern and efficient set of standards for the operation of Town Hall Center.

It is hard to realize, but within the next few months when we take over all the new facilities being built for us under our contract with Del E. Webb Development Company, Town Hall Center will own and operate approximately a MILLION DOLLARS worth of facilities and will have nearly six thousand members.

THIS IS NO LONGER A SMALL ENTERPRISE, but one requiring professional, paid management and operation to provide all of the constantly increasing services that are desired and required by the many members and organizations using the facilities.

Because of the many weaknesses, conflicts and omissions of our present By-Laws, over four month's study was made and as a result, on April 26, 1967, the Town Hall Board approved a complete new revision of our By-Laws. On May 8, 1967, these were presented in detail to the members at the regular Corporation meeting at Town Hall.

MONDAY, JUNE 5, 1967 was officially set as the date on which these By-Laws are to be voted on by the Town Hall members. So that each Town Hall member can be familiar with the new By-Laws, we are attaching them to this announcement and briefly giving you a few reasons why these new By-Laws are necessary.

In 1963, when Sun City Town Hall Corporation was formed and most of our present By-Laws were written, the entire Town Hall Center facilities were owned, operated and maintained by the Del E. Webb Development Company, who collected the membership fees, paid the bills and operated under their own Corporation Articles, by-laws, rules, etc. There were only some ten or eleven clubs, the total membership comparatively small, and the demands for facilities likewise. The Town Hall By-Laws primarily dealt with and were used in governing the Club operations and advisory aspects only.

And yet, on January 1, 1965, when these facilities were deeded over to the Sun City Town Hall Center and the members became solely responsible for its operation, those same Town Hall By-Laws had to be used to govern Town Hall, and its unpaid members were required to manage and operate the entire facilities. In 1965, as in the rapidly growing year of 1966, members of the Board and the Town Hall committees, who, you must remember, were serving without pay, found it had become an increasingly demanding job to run Town Hall and that the By-Laws did not spell out any provisions or rules for a paid manager and employee type operation. Believe us, it was only because of the many hours and intelligent work put in by such dedicated people as Lan Atkins, Chairman of the 1965 House Committee, and Clyde Wells, who held the same job in 1966, and others serving on the Board and Committees, that the job got done. Week after week, they put as much or more time in for Town Hall than they had on their jobs before retiring. This was asking too much from people who came here to retire.

As a result, in the spring of 1966, a professional manager was hired to run the physical operations of Town Hall, and for the first time under Town Hall ownership, the Board came face to face with the necessity for devising a set of rules spelling out the responsibilities and authority of a paid manager. Believe it or not, there was not one word in the entire By-Laws that mentioned an employee or provided any guide for the manager or operation with paid employees -- remember, prior to 1965, the Webb Company ran it themselves with their own manager and paid employees.

Space does not permit outlining all of the many other reasons for the new By-Laws, but many of them are self-explanatory, and these By-Laws, together with the Rules and Regulations mentioned, are contained in several books available for your inspection in the Town Hall offices.

SUN CITY TOWN HALL CENTER
BOARD OF DIRECTORS

BY-LAWS
(as amended)
SUN CITY TOWN HALL CENTER
(Hereinafter known as "Town Hall")

ARTICLE I - OFFICE

The principal office for the transaction of business of Town Hall shall be located in Sun City, Arizona.

ARTICLE II - MEMBERSHIP

SECTION 1. (a) Members shall be homeowners and/or residents occupying a house or apartment which is located as designated in the Articles of Incorporation.

(b) Membership shall not be transferable.

(c) A member must be current in the payment of the annual assessments to validate the membership and to entitle the member to all rights and privileges of same.

SECTION 2. (a) Privileges of members shall be to vote, to hold office, to use all available facilities, subject to the rules and regulations of Town Hall or approved for the chartered clubs, and to participate and become members of all activities and clubs of Town Hall. Members shall have certain guest privileges as provided in the "Rules and Regulations".

(b) No member shall be denied the use of any facilities of Town Hall even though he has no membership in any chartered club, and no chartered club shall have any rule or regulation, except those for the safety of persons and/or protection of property, prohibiting the use of any facility by such member.

(c) No member or group of members, whether or not sponsored by a chartered club, or any other person or persons, shall so conduct themselves in or on Town Hall property as to violate any local, county, state or federal law and/or jeopardize the rights and privileges of other Town Hall members, their guests or any other person or persons. A cease and desist order shall be issued by the Town Hall Board of Directors against such infractions and, upon failure of such infractors to comply with said order, denial of the use of Town Hall property for such practices shall be ordered by the Board.

SECTION 3. (a) The assessments for all members for each fiscal year (January 1 through December 31) shall be determined by the Board of Directors of this Corporation. Such assessments shall be due and payable January 1st of each year. Payment will entitle each member to a card which is valid in all Town Hall facilities. If home ownership should be established during the fiscal year, the assessment shall be prorated on a monthly basis until the end of the current fiscal year.

(b) An admission or re-admission fee of one hundred (100) dollars for application or restoration to membership after a delinquency of six (6) months in the payment of assessments due, or after withdrawal from membership, shall obtain.

SECTION 4. (a) A membership may be suspended or the member expelled by the Board of Directors, after a hearing by the Board, for non-compliance by such member with the provisions of the Articles, By-Laws, Rules and Regulations.

(b) Application for reinstatement may be filed with the Board of Directors after such suspension or expulsion has been effective for thirty (30) days. During the period of suspension or expulsion such member shall have no rights to utilize any of the facilities of Town Hall.

SECTION 5. (a) Regular corporation membership meetings shall be held during the months of January, May, September and November, at a place, date and hour to be set by the Board of Directors.

(b) One hundred (100) members may file a request with the Secretary of the Board of Directors for a special meeting, stating the reasons for the meeting. The President shall call such a special meeting within ten (10) days after receiving such request. A quorum for any meeting shall consist of not less than one hundred (100) members and Roberts' Rules of Order, Revised, shall prevail, except as provided in the By-Laws. A quorum shall be presumed in the absence of a challenge.

ARTICLE III - OFFICERS

SECTION 1. The officers of the Corporation shall be President, Vice-President, Secretary, and Treasurer.

SECTION 2. President. The President shall be Chairman of the Board of Directors and shall preside at and conduct all meetings by a formal order of business. He shall have general supervision and direction of the affairs of the Corporation in accordance with the By-Laws, shall have authority to administer all matters not otherwise expressly delegated, shall appoint all committees (with the consent and approval of the Board) except the Nominating, Balloting and Executive Committees, and shall call all special meetings of the Corporation and/or the Board of Directors.

SECTION 3. Vice-President. The Vice-President shall perform the duties of the President during the latter's absence.

SECTION 4. Secretary. The Secretary shall keep a record of the minutes of the meetings; shall send out notices of meetings and shall keep the members informed by bulletins from time to time as occasion warrants and shall perform such other duties as ordinarily pertain to that office.

SECTION 5. Treasurer. The Treasurer shall be the custodian of all funds of the Corporation and shall collect and disburse the same and keep a financial record thereof as prescribed by the Board of Directors and deposit them in the bank or banks designated by the Board of Directors; shall sign all checks which shall be countersigned by the President or such other officers or Board members as may be designated by the Board of Directors; shall issue financial statements when required and perform such other duties as ordinarily pertain to that office.

SECTION 6. All officers, Board members, Committee chairmen and members, and employees who are in any way involved in the handling of Corporation funds, and the paid manager of

the Corporation, shall be bonded in a sum to be determined by the Board of Directors.

SECTION 7. Term of office. The term of office of all elected officers shall be one year. Elected officers shall serve until their successors are duly elected and installed.

ARTICLE IV - BOARD OF DIRECTORS

SECTION 1. There shall be eleven (11) directors, including the four elected officers, none of whom shall receive a salary for his service to the Corporation.

SECTION 2. The four officers shall be elected annually; the other seven directors shall be elected for two year terms, three of them being elected in odd-numbered years, four in even-numbered years.

SECTION 3. Regular meetings shall be at Town Hall on the first Monday of each month at 9:00 AM, unless otherwise specified by the President, who shall preside at all meetings. Two-thirds of the members shall constitute a quorum. All meetings shall be conducted in accordance with the By-Laws and Roberts' Rules of Order, Revised, except as provided in the By-Laws.

SECTION 4. The Board of Directors shall hold and administer the assets, and shall direct, control, manage, and supervise the business and affairs of the Corporation.

SECTION 5. The Board of Directors shall have authority to make rules and regulations as deemed expedient and to incorporate in the By-Laws such rules and regulations by reference.

ARTICLE V - VACANCIES

SECTION 1. Removal. Action for removal of any elected officer or member of the Board of Directors may be initiated by not less than one hundred (100) members of the Corporation, who shall submit their reasons in writing to the Secretary. The request for recall shall be publicized for not less than twenty-six (26) days, after which and within seven (7) days the members of the Corporation may vote on the recall by secret ballot, according to Article IX of these By-Laws and the Rules and Regulations. Two-thirds of all votes cast at the last annual election in December shall be necessary for the recall of an elected officer or Board member.

SECTION 2. Vacancy. The Board of Directors may declare vacant the position of any officer or director who, without good and sufficient reasons acceptable to the remaining members of the Board, is absent from three or more consecutive regular meetings of the Board.

SECTION 3. Replacement. A vacancy on the Board of Directors or in any office, because of death, resignation, removal, disqualification or otherwise, shall be filled by the Board of Directors, subject to the approval of the members of the Corporation, by appointment of a member of the Corporation to serve until the next annual election. A director appointed to fill a vacancy shall serve for the unexpired term of his predecessor.

ARTICLE VI - COMMITTEES

SECTION 1. The President shall be empowered to appoint, with the consent and approval of the Board, such committees as he may deem necessary to properly and effectively carry on the affairs of the Corporation. This authority shall include all committees, standing and special, except the Nominating, Balloting, and Executive committees, which are specifically provided for in Articles VIII and IX of these By-Laws and/or the Rules and Regulations.

ARTICLE VII - CHARTERED CLUBS

SECTION 1. A chartered Town Hall club is one approved by the Board of Directors. Requirements for chartering, as well as the duties, responsibilities and authorities of such clubs are outlined in the "Club Organization" section of the Rules and Regulations. There shall be no conflict of club rules and regulations with the Articles of Incorporation and/or the By-Laws, and/or Rules and Regulations of this Corporation.

ARTICLE VIII - NOMINATION PROCEDURE

SECTION 1. The Nominating Committee shall submit a slate of officers and directors for consideration by the Board of Directors, consisting of at least two (2) candidates for each of the offices and director openings in accordance with approved procedure in the Rules and Regulations.

SECTION 2. The slate shall be announced at the regular November meeting of the Corporation and thereafter published and posted.

SECTION 3. The Board of Directors shall set the date and conduct the election in December not later than the 15th of that month.

ARTICLE IX - VOTING PROCEDURE

SECTION 1. Voting on all matters of business, whether by secret ballot or otherwise, shall be in accordance with the procedure as specified in the Rules and Regulations.

ARTICLE X - AMENDMENTS

SECTION 1. (a) Action on changes and/or amendments to the By-Laws may be initiated by the Board of Directors or by petition of at least one hundred (100) members of the Corporation. These By-Laws may be amended, modified or revoked by the Board of Directors or by the members, but such action by the Board shall be subject to approval by vote of the members at the first regular Corporation membership meeting following such Board action.

(b) In cases where the members initiate the action or where the Board submits the matter to a vote before making any changes and/or amendments, the proposed changes and/or amendments shall be given to the Board at least ten (10) days prior to a regularly scheduled meeting of the Corporation, at which meeting the proposed changes and/or amendments shall be read and voted upon.

(c) Voting shall be according to Article IX and the procedure outlined in the Rules and Regulations.

ARTICLE XI - RESTRICTION

SECTION 1. No Article, Section or Sub-section in these By-Laws shall be in conflict with the Articles of Incorporation.

May 8, 1967

September 11, 1967

FELLOW MEMBERS OF TOWN HALL:

Since Town Hall was incorporated in 1963, a great many changes have occurred and the by-laws which sufficed then, when Del Webb operated Town Hall, don't do a job for us now. Today we are three times as big as then, with over a million dollars in property and it takes a six-figure budget to run the place. So we must update our by-laws to fit our present operation with a full time professional manager.

Your By-Laws Revision Committee - Phil Campbell, Earl Holmes, George Jacobs, Art Mathis, Chris Nelson, Lin Price, Clyde Wells and Jack Jackley, chairman - has compiled a revised set of By-Laws which fully comply with our own Articles of Incorporation and with the Arizona Code, and which provide a vehicle for the smooth, efficient and economical operation of Town Hall in all its aspects. Here are the salient features:

Almost any corporation you can name - profit making or non-profit, from General Motors to our own local Home Owners' Association - votes for its directors and they, in turn, choose the officers. Under the proposed by-laws, Town Hall will adopt this standard procedure.

A professional manager to operate all facilities will be responsible to the Board thru the President, who is also required to appoint a Finance-Budget Committee to guard the finances, a Properties Committee to maintain constant vigilance over our physical properties, and a Committee on Committees to safeguard the nominating procedure of all candidates for the Board. No member of the Board may serve on the Nominating Committee.

Under current by-laws the recognized clubs name all candidates for the Nominating Committee; the new by-laws provide that only five members of this committee shall be chosen from names submitted by the clubs, and the other four members shall be chosen from the membership at large by the Committee on Committees.

At the tabulation of votes, the current by-laws permit as observers only persons designated by the clubs. The revised by-laws will allow any member of Town Hall in good standing to be an observer. The section on amendments to by-laws is now in full conformity with our own Articles of Incorporation and with the Arizona Code governing such matters.

Amendments to the Articles of Incorporation (see back of last page) cover the 2-year term for directors which was voted overwhelmingly last winter; the change-over to the system of voting for directors who will choose their own officers; and certain specific wording in Article XI which is necessary to conform to the Arizona Code.

We hope all of you will take time between now and September 25 to read over the entire set of proposed revisions and amendments and familiarize yourselves with them. Then, if you have any questions, drop in at the office at 10600 Peoria Avenue any day - Monday thru Friday - 10 a.m. to 4 p.m., and a member of the By-Laws Committee will be there to discuss such items with you.

These Articles of Incorporation, as amended, and the Revised By-Laws were submitted by the By-Laws Committee and approved by the Board of Directors at a special meeting called for that purpose at Town Hall Center on Monday, August 21, 1967; and will be presented to the Town Hall members to be voted on at 1:30 p.m. Monday, September 25, 1967, in the new Town Hall South auditorium. Come and bring your neighbor (and be sure both of you bring along your Town Hall membership cards to provide identification for voting).

BOARD OF DIRECTORS
SUN CITY TOWN HALL CENTER

VF - RECREATION CENTERS - FAIRWAY (TOWN HALL)

AMENDMENTS TO THE ARTICLES OF INCORPORATION
(As Amended Sept. 25, 1967)
SUN CITY TOWN HALL CENTER

SUN CITY, ARIZONA

Article VII is hereby amended to read as follows:

The affairs of the Corporation shall be conducted by a Board of Directors and such officers as the Board may elect or appoint. The number of Directors shall not be less than three (3) nor more than twenty-five (25), and shall be elected by the members at the annual meeting of the members of the Corporation, to be held on the first Thursday in December of each year, beginning with 1963; provided, however, that such date may be changed from time to time by the Board of Directors. The Directors shall be elected for a term of two (2) years. The following directors shall continue to serve until the annual Corporation membership meeting to be held on the first Thursday in December, 1968: Mrs. Bertha Cox, George H. Jacobs, John W. Prather, Alfred R. Voelker. All directors shall serve until their successors are elected and qualified; and shall elect annually from their own number the four officers for the current year.

The directors, subject to approval or veto by the members of the Corporation, shall have the power to adopt By-Laws for the Corporation. The By-Laws may be amended, modified, revised or revoked by the directors or by the members. In the event of conflict concerning the By-Laws as amended, modified, revised or revoked by the directors, the action of the members shall prevail. The procedure for the changing of any by-laws shall conform to and be consistent with the procedural method outlined in Article XI of the Articles of Incorporation.

The directors shall have power to fill vacancies occurring in the board or in any office, subject to approval or veto by the members. The Board may appoint from its own number an executive committee and invest such committee with such powers as may be approved by the directors.

The by-laws of the Corporation shall prescribe the qualifications of members and the terms of admission to membership, provided that the voting rights of all active members shall be equal and all active members shall have equal rights and privileges and be subject to equal responsibilities. Such by-laws shall also provide the fees of admission, dues and assessments to be paid by the members and the grounds for and the manner in which members may withdraw, be suspended or expelled.

- - -

Article XI is hereby amended to read as follows:

These Articles of Incorporation may be amended at any meeting of the members called for that purpose (by the Board of Directors or by at least one hundred (100) members of this Corporation who petition for such a meeting), by an affirmative vote of a majority of the members of the corporation present at the meeting. Notice of any proposed amendment or amendments shall be given by written notice to the directors at least ten (10) days prior to a regular Board meeting, and by publication once a week for two consecutive weeks prior to the Corporation membership meeting, in a newspaper or newspapers of general circulation in the county wherein the Articles of Incorporation were published; and by posting on the Town Hall bulletin boards two weeks prior to the Corporation membership meeting.

- (b) These By-Laws may be amended at any meeting of the members called for that purpose (by the Board of Directors or by at least one hundred (100) members of this Corporation who petition for such meeting) by an affirmative vote of a majority of the members present at the meeting. Notice of any proposed amendmat or amendments shall be given by written notice to the Directors at least ten (10) days prior to a regular Board meeting, and by publication once a week for two consecutive weeks prior to the Corporation membership meeting, in a newspaper or newspapers of general circulation in the county wherein the Articles of Incorporation were published, and by posting upon the Town Hall bulletin boards two weeks prior to the Corporation membership meeting.
- (c) Voting procedures outlined in Article IX shall apply.

ARTICLE XI - RESTRICTION

SECTION 1. No Article, Section or Sub-Section in these By-Laws shall be in conflict with the Articles of Incorporation, as amended.

BY-LAWS
(As Revised Sept. 25, 1967)

SUN CITY TOWN HALL CENTER
(Hereinafter known as "Town Hall")

ARTICLE I - OFFICE

The principal office for the transaction of business of Town Hall shall be located in Sun City, Arizona.

ARTICLE II - MEMBERSHIP

SECTION 1. (a) Members shall be homeowners and/or residents occupying a house or apartment which is located as designated in the Articles of Incorporation, as amended. Residents of Sun Valley Lodge who were members in good standing at the time of moving to the Lodge may continue their memberships by payment of the current annual assessments.

(b) Membership shall not be transferable.

(c) A member must be current in the payment of the annual assessments to validate the membership and to entitle the member to all rights and privileges of same.

SECTION 2. (a) Privileges of members shall be to vote, to hold office, to use all available facilities, subject to the rules and regulations of Town Hall or approved for the chartered clubs, and to participate and become members of all activities and clubs of Town Hall. Members shall have certain guest privileges as provided in the "Rules and Regulations".

(b) No member shall be denied the use of any facilities of Town Hall even though he has no membership in any chartered club, and no chartered club shall have any rule or regulation, except those for the safety of persons and/or protection of property, prohibiting the use of any facility by such member.

(c) No member or group of members, whether or not sponsored by a chartered club, or any other person or persons, shall so conduct themselves in or on Town Hall property as to jeopardize the rights and privileges of other Town Hall members, their guests or any other person or persons. A cease and desist order shall be issued by the Town Hall Board of Directors against such infractions and, upon failure of such infractors to comply with said order, denial of the use of Town Hall property for such practices shall be ordered by the Board.

SECTION 3. (a) The assessments for all members for each fiscal year (January 1 through December 31) shall be determined by the Board of Directors of this Corporation. Such assessments shall be due and payable January 1st of each year. Payment will entitle each member to a card which is valid in all Town Hall facilities. If membership should be established during the fiscal year, the assessment shall be prorated on a monthly basis until the end of the current fiscal year.

(b) An admission fee of one hundred (100) dollars shall be charged any person who delays more than six (6) months in applying for membership after becoming eligible for same. A re-admission fee of one hundred (100) dollars may be charged for restoration to membership after default of membership due to delinquency of six (6) months in the payment of assessments due, or after withdrawal from membership.

SECTION 4. (a) A membership may be suspended or the member expelled by the Board of Directors, after a hearing by the Board, for non-compliance by such member with the provisions of the Articles, By-Laws, Rules and Regulations.

(b) Application for reinstatement may be filed with the Board of Directors after such suspension or expulsion has been effective for thirty (30) days. During the period of suspension or expulsion such member shall have no rights to utilize any of the facilities of Town Hall.

SECTION 5. (a) Quarterly corporation membership meetings shall be held each year on the second Monday during the months of January, May, September and November. The annual corporation membership meeting shall be held on the first Thursday in December, at which time the election will be held for the directorships.

(b) One hundred (100) members may file a request with the Secretary of the Board of Directors for a special meeting, stating the reasons for the meeting. Within ten (10) days after receiving such request, the President shall call a special meeting to be held within thirty (30) days. A quorum for any meeting shall consist of not less than one hundred (100) members and Roberts' Rules of Order, Revised, shall prevail, except as provided in the By-Laws. A quorum shall be presumed in the absence of a challenge.

ARTICLE III - BOARD OF DIRECTORS

SECTION 1. There shall be nine (9) directors, including the officers, none of whom shall receive compensation of any kind for his service to the Corporation. At the regular Board meeting in January of each year the newly elected directors shall be installed and the members of the Board shall then select from their own number the four officers listed in Article IV, who shall serve during that calendar year and until their successors are chosen and installed.

SECTION 2. At the first meeting of the Board of Directors a temporary chairman shall be appointed and the first order of business at this meeting shall be the election of officers. Election procedure shall be as follows:

Each member of the Board of Directors shall be given a list of all directors, alphabetically arranged.

Each director shall mark on his list his choice for President, for Vice-President, for Secretary and for Treasurer.

A committee of tellers appointed by the temporary chairman shall collect and tally the votes as indicated on these lists and the temporary chairman shall, upon receiving the tally, announce the results and shall declare the one receiving the most votes for each office duly elected to that office to serve during the current year or until a successor has been elected and qualified.

Whereupon the temporary chairman shall turn the meeting over to the newly elected President.

SECTION 3. Term of office. All directors shall be elected for a two-year term; four being elected in each even-numbered year and five in each odd-numbered year.

SECTION 4. Regular meetings shall be at Town Hall on the first Monday of each month at 9:00 AM, unless otherwise specified by the President, who shall preside at all meetings. Two-thirds of the members of the Board shall constitute a quorum. All meetings shall be conducted in accordance with the By-Laws and Roberts' Rules of Order, Revised, except as provided in the By-Laws.

SECTION 5. The Board of Directors shall hold and administer the assets, and shall direct, control, manage, and supervise the business and affairs of the Corporation.

SECTION 6. The Board of Directors shall have authority to make rules and regulations as deemed expedient and within the authority as outlined in the Articles of Incorporation and the By-Laws as amended. There shall be copies of the complete Rules and Regulations available to all members of Town Hall in the Town Hall offices at all hours when such offices are open for business, but such copies may not be removed from the premises.

SECTION 7. The Board of Directors shall have the authority to hire a manager and such other employees as are deemed necessary for the proper operation of Town Hall and its facilities, including the authority to dismiss such employees when deemed advisable. The manager's principal duties are as outlined in the Rules and Regulations, but the Board of Directors shall have authority to prescribe such additional duties for the manager as may be required for the best operation of Town Hall. The manager shall report through the President to the Board of Directors. The manager shall give a complete written report of the state of affairs concerning the operation of Town Hall at each regular monthly meeting of the Board of Directors, and to the members at each quarterly Corporation meeting.

ARTICLE IV - OFFICERS

SECTION 1. The officers of the Corporation shall be President, Vice-President, Secretary, and Treasurer.

SECTION 2. President. The President shall be Chairman of the Board of Directors and shall preside at and conduct all meetings by a formal order of business. He shall have general supervision and direction of the affairs of the Corporation in accordance with the Articles of Incorporation and the By-Laws, shall have authority to administer all matters not otherwise expressly delegated, shall appoint all committees (with the consent and approval of the Board) except the Nominating and Balloting Committees, and shall call all special meetings of the Corporation and/or the Board of Directors.

SECTION 3. Vice-President. The Vice-President shall perform the duties of the President during the latter's absence.

SECTION 4. Secretary. The Secretary shall keep a record of the minutes of the meetings, shall send out notices of meetings and shall keep the members informed by bulletins from time to time as occasion warrants and shall perform such other duties as ordinarily pertain to that office.

SECTION 5. (a) Treasurer. The Treasurer shall be the custodian of all funds of the Corporation and shall collect and disburse the same and keep a financial record thereof as prescribed by the Board of Directors, and deposit them to the account of Sun City Town Hall Center in the bank or banks designated by the Board of Directors; shall sign all checks which shall be countersigned by the President or such other officers or Board members as may be designated by the Board of Directors; shall issue financial statements when required, including regularly scheduled Corporation meetings, and perform such other duties as ordinarily pertain to that office. His financial records shall be audited at the close of the fiscal year by a certified public accountant, as selected by the Board of Directors.

(b) The Board of Directors may appoint an assistant treasurer to serve at the discretion of the Board. Such assistant treasurer shall, in the absence or incapacity of the Treasurer, have the powers, duties, and the responsibilities of the Treasurer, but shall receive no compensation therefor.

SECTION 6. All officers, Board members, Committee chairmen and members, and employees who are in any way involved in the handling of Corporation funds, and the paid manager of the Corporation, shall be bonded in a sum to be determined by the Board of Directors.

SECTION 7. The term of office of all officers shall be one year, as provided in Section 1 of Article III. Elected officers shall serve until their successors are duly elected and installed.

ARTICLE V - VACANCIES

SECTION 1. Removal. Action for removal of any elected officer or member of the Board of Directors may be initiated by not less than one hundred (100) members of the Corporation, who shall submit their reasons in writing to the Secretary. The request for recall shall be publicized for not less than twenty-six (26) days, after which and within seven (7) days the members of the Corporation may vote on the recall by secret ballot, according to Article IX of these By-Laws. An affirmative vote equal to two-thirds of all votes cast at the last annual election in December shall be necessary for the recall of an elected officer or Board member.

SECTION 2. Vacancy. The Board of Directors may declare vacant the position of any officer or director who, without good and sufficient reasons acceptable to the remaining members of the Board, is absent from three or more consecutive regular meetings of the Board.

SECTION 3. Replacement. A vacancy on the Board of Directors, or in any office, because of death, resignation, removal, disqualification or otherwise, shall be filled by the Board of Directors by appointment of a member of the Corporation to serve for the unexpired term of his predecessor, subject to the approval of the members of the Corporation at the next quarterly Corporation meeting.

ARTICLE VI - COMMITTEES

SECTION 1. (a) The President shall be empowered to appoint, with the consent and approval of the Board, such committees as he may deem necessary to properly and effectively carry on the affairs of the Corporation, but it shall be mandatory, at the next regular board meeting after election of the President, that a Finance-Budget Committee, a Properties Committee, and a Committee on Committees of not less than five (5) nor more than nine (9) members, with a member of the Board as chairman of each, be included in these appointments. This authority shall include all committees, standing and special, except the Nominating and Balloting Committees which are specifically provided for in Articles VIII and IX, respectively, of these By-Laws.

(b) FINANCE-BUDGET COMMITTEE - Will have general control of the financial policy, subject to the approval of the Board of Directors, including ways and means for obtaining funds necessary to meet the authorized budget for carrying out the work of the Corporation. Will present in writing, not later than December 15 of each year, an itemized estimate of the income and expenses for the ensuing year which, upon approval of the Board of Directors, shall become the authorized budget for that year, and no obligation beyond the amount thus authorized shall be incurred by any committee or agent of the Corporation unless specially authorized by the Board of Directors. The Rules and Regulations shall outline methods for periodic audits and inventory checks by this committee.

(c) PROPERTIES COMMITTEE - Will be composed of members particularly skilled in the various technical requirements to function properly. This committee shall conduct at least once every sixty (60) days a complete inspection of all the Town Hall physical properties, including the buildings, equipment and grounds, to determine if same are safe, are being properly cared for, and are in good condition. After each inspection, the chairman shall make a report in writing to the Board of Directors of the status of the facilities, including any recommendations that may be necessary for the better preservation and care of the facilities, or replacements of equipment as needed. The Committee shall have no other authority.

(d) COMMITTEE ON COMMITTEES - Will recommend qualified persons to the President for committee membership, and conduct nominating procedure as outlined in Article VIII of these By-Laws.

ARTICLE VII - CHARTERED CLUBS

SECTION 1. A chartered Town Hall club is one approved by the Board of Directors. Requirements for chartering, as well as the duties, responsibilities and authorities of such clubs are outlined in the "Club Organization" section of the Rules and Regulations. There shall be no conflict of club rules and regulations with the Articles of Incorporation and/or the By-Laws, and/or Rules and Regulations of this Corporation, as amended. These Club Rules and Regulations shall be posted at all times on the Town Hall bulletin boards and will be available to all clubs and organizations and individuals using Town Hall facilities.

ARTICLE VIII - NOMINATION PROCEDURE

SECTION 1. A Nominating Committee of nine (9) members shall make nominations at the Corporation membership meeting in November of each odd-numbered year for the five (5) directors of the Board to be elected in that year; and in each even-numbered year for the four (4) directors to be elected in that year.

SECTION 2. The Nominating Committee shall consist only of Town Hall residents, who are members in good standing, to be chosen as follows:

(a) Not later than September 15 of each year, each chartered Town Hall club shall submit in writing the name of one of its members to the Chairman of the Committee on Committees, for consideration as a member of the Nominating Committee.

(b) The Committee on Committees shall transmit to the Board of Directors not later than October 1, at least fifteen (15) of the submitted names.

(c) The Board of Directors, at their regular October meeting, shall select five (5) names from the list submitted and, in addition, the Committee on Committees shall select four (4) names to represent the membership at large. These nine (9) persons shall serve as the Nominating Committee and the Board shall arrange appropriate announcement of the same.

(d) The President shall call the first meeting of the Nominating Committee, at which time he will outline the duties and responsibilities of the Committee. The Committee will elect its chairman and the President will then retire from the meeting place.

SECTION 3. The Nominating Committee shall prepare a slate of not less than two (2) persons for each board seat to be filled at the upcoming election. This slate and any nominations from the floor at the November meeting shall be publicized in the same manner as for amending the Articles of Incorporation and shall be posted by listing the names of the nominees in alphabetical order on the official bulletin boards immediately after the slate has been announced at the November meeting. Announcement shall also be made at this meeting of the hours and place for voting.

SECTION 4. A candidate and/or nominee must be a Town Hall member in good standing and a resident of the Town Hall area. Any member of the Nominating Committee, if requested by the Committee, may be nominated. Any person nominated shall declare his availability for attendance at necessary meetings of the Board and shall make himself available for any office to which the Board may elect him.

SECTION 5. There shall be no members of the Board on the Nominating Committee.

ARTICLE IX - VOTING PROCEDURE

SECTION 1. A voice or standing vote or show of hands shall prevail on all matters of business, except as follows when a secret ballot will be required:

- (a) The election of all directors.
- (b) Recall of any officer and/or any member of the Board of Directors.
- (c) When a majority of the Board of Directors request a secret ballot.
- (d) When a secret ballot is requested by a majority vote of the eligible members of the Corporation at any meeting.

SECTION 2. When a secret ballot is required on (a), (b), or (c) above, the following will apply:

- (a) The subject shall be voted on in direct accordance with the procedures as outlined in Articles VII or XI of the Articles of Incorporation as they may apply.
- (b) Voting shall proceed under supervision of the Balloting Committee composed of five (5) members of the Board of Directors appointed by the Board. No nominee may serve on or assist the Balloting Committee. Ballot boxes and election procedure shall be prepared by this Committee.
- (c) At least two (2) members of the Balloting Committee shall be in attendance at all times during voting and they shall determine eligibility (Article II of the By-Laws) of all voters, issue all official ballots and witness the casting of the ballots.
- (d) Ballot boxes shall remain sealed until all votes are cast, then opened and votes tabulated in the presence of at least three (3) members of the Balloting Committee. Upon completion of the tabulation of ballots, the results shall be certified by balloting chairman to the Board and officially posted on Town Hall bulletin boards.
- (e) Any Town Hall member may be present as an observer at the tabulation of votes.

- SECTION 3.
- (a) An eligible voter (Article II of By-Laws) if he will be absent from Maricopa County on the date set for balloting, may cast an absentee ballot at the place or time, or by mail, as designated by the Balloting Committee, but not more than fourteen (14) days nor less than three (3) days prior to the voting date.
 - (b) When requested by an ill or incapacitated eligible voter (Article II of By-Laws) not more than five days nor less than two days prior to the voting date, any two members of the Balloting Committee shall take an official ballot and a sealed ballot box to his home and witness the casting of his absentee ballot.
 - (c) Ballot boxes containing absentee votes shall be opened and the ballots tabulated at the same time and place and under the same conditions as the regular ballots.
 - (d) Following tabulation, all ballots will be sealed and stored for a period of thirty (30) days, in custody of the Board of Directors.

ARTICLE X - AMENDMENTS

SECTION 1. (a) Action on changes and/or amendments to the By-Laws may be initiated by the Board of Directors or by petition of at least one hundred (100) members of the Corporation. These By-Laws may be amended, modified, revised or revoked by the Board of Directors or by the members, but such action by the Board shall be subject to approval by vote of the members at the first quarterly Corporation membership meeting following such Board action, or at a meeting called for that purpose.

BY-LAWS
(As Revised Sept. 25, 1967)

SUN CITY TOWN HALL CENTER
(Hereinafter known as "Town Hall")

ARTICLE I - OFFICE

The principal office for the transaction of business of Town Hall shall be located in Sun City, Arizona.

ARTICLE II - MEMBERSHIP

SECTION 1. (a) Members shall be homeowners and/or residents occupying a house or apartment which is located as designated in the Articles of Incorporation, as amended. Residents of Sun Valley Lodge who were members in good standing at the time of moving to the Lodge may continue their memberships by payment of the current annual assessments.

(b) Membership shall not be transferable.

(c) A member must be current in the payment of the annual assessments to validate the membership and to entitle the member to all rights and privileges of same.

SECTION 2. (a) Privileges of members shall be to vote, to hold office, to use all available facilities, subject to the rules and regulations of Town Hall or approved for the chartered clubs, and to participate and become members of all activities and clubs of Town Hall. Members shall have certain guest privileges as provided in the "Rules and Regulations".

(b) No member shall be denied the use of any facilities of Town Hall even though he has no membership in any chartered club, and no chartered club shall have any rule or regulation, except those for the safety of persons and/or protection of property, prohibiting the use of any facility by such member.

(c) No member or group of members, whether or not sponsored by a chartered club, or any other person or persons, shall so conduct themselves in or on Town Hall property as to jeopardize the rights and privileges of other Town Hall members, their guests or any other person or persons. A cease and desist order shall be issued by the Town Hall Board of Directors against such infractions and, upon failure of such infractors to comply with said order, denial of the use of Town Hall property for such practices shall be ordered by the Board.

SECTION 3. (a) The assessments for all members for each fiscal year (January 1 through December 31) shall be determined by the Board of Directors of this Corporation. Such assessments shall be due and payable January 1st of each year. Payment will entitle each member to a card which is valid in all Town Hall facilities. If membership should be established during the fiscal year, the assessment shall be prorated on a monthly basis until the end of the current fiscal year.

(b) An admission fee of one hundred (100) dollars shall be charged any person who delays more than six (6) months in applying for membership after becoming eligible for same. A re-admission fee of one hundred (100) dollars may be charged for restoration to membership after default of membership due to delinquency of six (6) months in the payment of assessments due, or after withdrawal from membership.

SECTION 4. (a) A membership may be suspended or the member expelled by the Board of Directors, after a hearing by the Board, for non-compliance by such member with the provisions of the Articles, By-Laws, Rules and Regulations.

(b) Application for reinstatement may be filed with the Board of Directors after such suspension or expulsion has been effective for thirty (30) days. During the period of suspension or expulsion such member shall have no rights to utilize any of the facilities of Town Hall.

SECTION 5. (a) Quarterly corporation membership meetings shall be held each year on the second Monday during the months of January, May, September and November. The annual corporation membership meeting shall be held on the first Thursday in December, at which time the election will be held for the directorships.

(b) One hundred (100) members may file a request with the Secretary of the Board of Directors for a special meeting, stating the reasons for the meeting. Within ten (10) days after receiving such request, the President shall call a special meeting to be held within thirty (30) days. A quorum for any meeting shall consist of not less than one hundred (100) members and Roberts' Rules of Order, Revised, shall prevail, except as provided in the By-Laws. A quorum shall be presumed in the absence of a challenge.

ARTICLE III - BOARD OF DIRECTORS

SECTION 1. There shall be nine (9) directors, including the officers, none of whom shall receive compensation of any kind for his service to the Corporation. At the regular Board meeting in January of each year the newly elected directors shall be installed and the members of the Board shall then select from their own number the four officers listed in Article IV, who shall serve during that calendar year and until their successors are chosen and installed.

SECTION 2. At the first meeting of the Board of Directors a temporary chairman shall be appointed and the first order of business at this meeting shall be the election of officers. Election procedure shall be as follows:

Each member of the Board of Directors shall be given a list of all directors, alphabetically arranged.

Each director shall mark on his list his choice for President, for Vice-President, for Secretary and for Treasurer.

A committee of tellers appointed by the temporary chairman shall collect and tally the votes as indicated on these lists and the temporary chairman shall, upon receiving the tally, announce the results and shall declare the one receiving the most votes for each office duly elected to that office to serve during the current year or until a successor has been elected and qualified.

Whereupon the temporary chairman shall turn the meeting over to the newly elected President.

SECTION 3. Term of office. All directors shall be elected for a two-year term; four being elected in each even-numbered year and five in each odd-numbered year.

SECTION 4. Regular meetings shall be at Town Hall on the first Monday of each month at 9:00 AM, unless otherwise specified by the President, who shall preside at all meetings. Two-thirds of the members of the Board shall constitute a quorum. All meetings shall be conducted in accordance with the By-Laws and Roberts' Rules of Order, Revised, except as provided in the By-Laws.

SECTION 5. The Board of Directors shall hold and administer the assets, and shall direct, control, manage, and supervise the business and affairs of the Corporation.

SECTION 6. The Board of Directors shall have authority to make rules and regulations as deemed expedient and within the authority as outlined in the Articles of Incorporation and the By-Laws as amended. There shall be copies of the complete Rules and Regulations available to all members of Town Hall in the Town Hall offices at all hours when such offices are open for business, but such copies may not be removed from the premises.

SECTION 7. The Board of Directors shall have the authority to hire a manager and such other employees as are deemed necessary for the proper operation of Town Hall and its facilities, including the authority to dismiss such employees when deemed advisable. The manager's principal duties are as outlined in the Rules and Regulations, but the Board of Directors shall have authority to prescribe such additional duties for the manager as may be required for the best operation of Town Hall. The manager shall report through the President to the Board of Directors. The manager shall give a complete written report of the state of affairs concerning the operation of Town Hall at each regular monthly meeting of the Board of Directors, and to the members at each quarterly Corporation meeting.

ARTICLE IV - OFFICERS

SECTION 1. The officers of the Corporation shall be President, Vice-President, Secretary, and Treasurer.

SECTION 2. President. The President shall be Chairman of the Board of Directors and shall preside at and conduct all meetings by a formal order of business. He shall have general supervision and direction of the affairs of the Corporation in accordance with the Articles of Incorporation and the By-Laws, shall have authority to administer all matters not otherwise expressly delegated, shall appoint all committees (with the consent and approval of the Board) except the Nominating and Balloting Committees, and shall call all special meetings of the Corporation and/or the Board of Directors.

SECTION 3. Vice-President. The Vice-President shall perform the duties of the President during the latter's absence.

SECTION 4. Secretary. The Secretary shall keep a record of the minutes of the meetings, shall send out notices of meetings and shall keep the members informed by bulletins from time to time as occasion warrants and shall perform such other duties as ordinarily pertain to that office.

SECTION 5. (a) Treasurer. The Treasurer shall be the custodian of all funds of the Corporation and shall collect and disburse the same and keep a financial record thereof as prescribed by the Board of Directors, and deposit them to the account of Sun City Town Hall Center in the bank or banks designated by the Board of Directors; shall sign all checks which shall be countersigned by the President or such other officers or Board members as may be designated by the Board of Directors; shall issue financial statements when required, including regularly scheduled Corporation meetings, and perform such other duties as ordinarily pertain to that office. His financial records shall be audited at the close of the fiscal year by a certified public accountant, as selected by the Board of Directors.

(b) The Board of Directors may appoint an assistant treasurer to serve at the discretion of the Board. Such assistant treasurer shall, in the absence or incapacity of the Treasurer, have the powers, duties, and the responsibilities of the Treasurer, but shall receive no compensation therefor.

SECTION 6. All officers, Board members, Committee chairmen and members, and employees who are in any way involved in the handling of Corporation funds, and the paid manager of the Corporation, shall be bonded in a sum to be determined by the Board of Directors.

SECTION 7. The term of office of all officers shall be one year, as provided in Section 1 of Article III. Elected officers shall serve until their successors are duly elected and installed.

ARTICLE V - VACANCIES

SECTION 1. Removal. Action for removal of any elected officer or member of the Board of Directors may be initiated by not less than one hundred (100) members of the Corporation, who shall submit their reasons in writing to the Secretary. The request for recall shall be publicized for not less than twenty-six (26) days, after which and within seven (7) days the members of the Corporation may vote on the recall by secret ballot, according to Article IX of these By-Laws. An affirmative vote equal to two-thirds of all votes cast at the last annual election in December shall be necessary for the recall of an elected officer or Board member.

SECTION 2. Vacancy. The Board of Directors may declare vacant the position of any officer or director who, without good and sufficient reasons acceptable to the remaining members of the Board, is absent from three or more consecutive regular meetings of the Board.

SECTION 3. Replacement. A vacancy on the Board of Directors, or in any office, because of death, resignation, removal, disqualification or otherwise, shall be filled by the Board of Directors by appointment of a member of the Corporation to serve for the unexpired term of his predecessor, subject to the approval of the members of the Corporation at the next quarterly Corporation meeting.

ARTICLE VI - COMMITTEES

SECTION 1. (a) The President shall be empowered to appoint, with the consent and approval of the Board, such committees as he may deem necessary to properly and effectively carry on the affairs of the Corporation, but it shall be mandatory, at the next regular board meeting after election of the President, that a Finance-Budget Committee, a Properties Committee, and a Committee on Committees of not less than five (5) nor more than nine (9) members, with a member of the Board as chairman of each, be included in these appointments. This authority shall include all committees, standing and special, except the Nominating and Balloting Committees which are specifically provided for in Articles VIII and IX, respectively, of these By-Laws.

(b) FINANCE-BUDGET COMMITTEE - Will have general control of the financial policy, subject to the approval of the Board of Directors, including ways and means for obtaining funds necessary to meet the authorized budget for carrying out the work of the Corporation. Will present in writing, not later than December 15 of each year, an itemized estimate of the income and expenses for the ensuing year which, upon approval of the Board of Directors, shall become the authorized budget for that year, and no obligation beyond the amount thus authorized shall be incurred by any committee or agent of the Corporation unless specially authorized by the Board of Directors. The Rules and Regulations shall outline methods for periodic audits and inventory checks by this committee.

(c) PROPERTIES COMMITTEE - Will be composed of members particularly skilled in the various technical requirements to function properly. This committee shall conduct at least once every sixty (60) days a complete inspection of all the Town Hall physical properties, including the buildings, equipment and grounds, to determine if same are safe, are being properly cared for, and are in good condition. After each inspection, the chairman shall make a report in writing to the Board of Directors of the status of the facilities, including any recommendations that may be necessary for the better preservation and care of the facilities, or replacements of equipment as needed. The Committee shall have no other authority.

(d) COMMITTEE ON COMMITTEES - Will recommend qualified persons to the President for committee membership, and conduct nominating procedure as outlined in Article VIII of these By-Laws.

ARTICLE VII - CHARTERED CLUBS

SECTION 1. A chartered Town Hall club is one approved by the Board of Directors. Requirements for chartering, as well as the duties, responsibilities and authorities of such clubs are outlined in the "Club Organization" section of the Rules and Regulations. There shall be no conflict of club rules and regulations with the Articles of Incorporation and/or the By-Laws, and/or Rules and Regulations of this Corporation, as amended. These Club Rules and Regulations shall be posted at all times on the Town Hall bulletin boards and will be available to all clubs and organizations and individuals using Town Hall facilities.

ARTICLE VIII - NOMINATION PROCEDURE

SECTION 1. A Nominating Committee of nine (9) members shall make nominations at the Corporation membership meeting in November of each odd-numbered year for the five (5) directors of the Board to be elected in that year; and in each even-numbered year for the four (4) directors to be elected in that year.

SECTION 2. The Nominating Committee shall consist only of Town Hall residents, who are members in good standing, to be chosen as follows:

(a) Not later than September 15 of each year, each chartered Town Hall club shall submit in writing the name of one of its members to the Chairman of the Committee on Committees, for consideration as a member of the Nominating Committee.

(b) The Committee on Committees shall transmit to the Board of Directors not later than October 1, at least fifteen (15) of the submitted names.

(c) The Board of Directors, at their regular October meeting, shall select five (5) names from the list submitted and, in addition, the Committee on Committees shall select four (4) names to represent the membership at large. These nine (9) persons shall serve as the Nominating Committee and the Board shall arrange appropriate announcement of the same.

(d) The President shall call the first meeting of the Nominating Committee, at which time he will outline the duties and responsibilities of the Committee. The Committee will elect its chairman and the President will then retire from the meeting place.

SECTION 3. The Nominating Committee shall prepare a slate of not less than two (2) persons for each board seat to be filled at the upcoming election. This slate and any nominations from the floor at the November meeting shall be publicized in the same manner as for amending the Articles of Incorporation and shall be posted by listing the names of the nominees in alphabetical order on the official bulletin boards immediately after the slate has been announced at the November meeting. Announcement shall also be made at this meeting of the hours and place for voting.

SECTION 4. A candidate and/or nominee must be a Town Hall member in good standing and a resident of the Town Hall area. Any member of the Nominating Committee, if requested by the Committee, may be nominated. Any person nominated shall declare his availability for attendance at necessary meetings of the Board and shall make himself available for any office to which the Board may elect him.

SECTION 5. There shall be no members of the Board on the Nominating Committee.

ARTICLE IX - VOTING PROCEDURE

SECTION 1. A voice or standing vote or show of hands shall prevail on all matters of business, except as follows when a secret ballot will be required:

- (a) The election of all directors.
- (b) Recall of any officer and/or any member of the Board of Directors.
- (c) When a majority of the Board of Directors request a secret ballot.
- (d) When a secret ballot is requested by a majority vote of the eligible members of the Corporation at any meeting.

SECTION 2. When a secret ballot is required on (a), (b), or (c) above, the following will apply:

- (a) The subject shall be voted on in direct accordance with the procedures as outlined in Articles VII or XI of the Articles of Incorporation as they may apply.
- (b) Voting shall proceed under supervision of the Balloting Committee composed of five (5) members of the Board of Directors appointed by the Board. No nominee may serve on or assist the Balloting Committee. Ballot boxes and election procedure shall be prepared by this Committee.
- (c) At least two (2) members of the Balloting Committee shall be in attendance at all times during voting and they shall determine eligibility (Article II of the By-Laws) of all voters, issue all official ballots and witness the casting of the ballots.
- (d) Ballot boxes shall remain sealed until all votes are cast, then opened and votes tabulated in the presence of at least three (3) members of the Balloting Committee. Upon completion of the tabulation of ballots, the results shall be certified by balloting chairman to the Board and officially posted on Town Hall bulletin boards.
- (e) Any Town Hall member may be present as an observer at the tabulation of votes.

SECTION 3.

- (a) An eligible voter (Article II of By-Laws) if he will be absent from Maricopa County on the date set for balloting, may cast an absentee ballot at the place or time, or by mail, as designated by the Balloting Committee, but not more than fourteen (14) days nor less than three (3) days prior to the voting date.
- (b) When requested by an ill or incapacitated eligible voter (Article II of By-Laws) not more than five days nor less than two days prior to the voting date, any two members of the Balloting Committee shall take an official ballot and a sealed ballot box to his home and witness the casting of his absentee ballot.
- (c) Ballot boxes containing absentee votes shall be opened and the ballots tabulated at the same time and place and under the same conditions as the regular ballots.
- (d) Following tabulation, all ballots will be sealed and stored for a period of thirty (30) days, in custody of the Board of Directors.

ARTICLE X - AMENDMENTS

SECTION 1. (a) Action on changes and/or amendments to the By-Laws may be initiated by the Board of Directors or by petition of at least one hundred (100) members of the Corporation. These By-Laws may be amended, modified, revised or revoked by the Board of Directors or by the members, but such action by the Board shall be subject to approval by vote of the members at the first quarterly Corporation membership meeting following such Board action, or at a meeting called for that purpose.

- (b) These By-Laws may be amended at any meeting of the members called for that purpose (by the Board of Directors or by at least one hundred (100) members of this Corporation who petition for such meeting) by an affirmative vote of a majority of the members present at the meeting. Notice of any proposed amendmat or amendments shall be given by written notice to the Directors at least ten (10) days prior to a regular Board meeting, and by publication once a week for two consecutive weeks prior to the Corporation membership meeting, in a newspaper or newspapers of general circulation in the county wherein the Articles of Incorporation were published, and by posting upon the Town Hall bulletin boards two weeks prior to the Corporation membership meeting.
- (c) Voting procedures outlined in Article IX shall apply.

ARTICLE XI -- RESTRICTION

SECTION 1. No Article, Section or Sub-Section in these By-Laws shall be in conflict with the Articles of Incorporation, as amended.

AMENDMENTS TO THE ARTICLES OF INCORPORATION
(As Amended Sept. 25, 1967)
SUN CITY TOWN HALL CENTER

SUN CITY, ARIZONA

Article VII is hereby amended to read as follows:

The affairs of the Corporation shall be conducted by a Board of Directors and such officers as the Board may elect or appoint. The number of Directors shall not be less than three (3) nor more than twenty-five (25), and shall be elected by the members at the annual meeting of the members of the Corporation, to be held on the first Thursday in December of each year, beginning with 1963; provided, however, that such date may be changed from time to time by the Board of Directors. The Directors shall be elected for a term of two (2) years. The following directors shall continue to serve until the annual Corporation membership meeting to be held on the first Thursday in December, 1968: Mrs. Bertha Cox, George H. Jacobs, John W. Prather, Alfred R. Voelker. All directors shall serve until their successors are elected and qualified; and shall elect annually from their own number the four officers for the current year.

The directors, subject to approval or veto by the members of the Corporation, shall have the power to adopt By-Laws for the Corporation. The By-Laws may be amended, modified, revised or revoked by the directors or by the members. In the event of conflict concerning the By-Laws as amended, modified, revised or revoked by the directors, the action of the members shall prevail. The procedure for the changing of any by-laws shall conform to and be consistent with the procedural method outlined in Article XI of the Articles of Incorporation.

The directors shall have power to fill vacancies occurring in the board or in any office, subject to approval or veto by the members. The Board may appoint from its own number an executive committee and invest such committee with such powers as may be approved by the directors.

The by-laws of the Corporation shall prescribe the qualifications of members and the terms of admission to membership, provided that the voting rights of all active members shall be equal and all active members shall have equal rights and privileges and be subject to equal responsibilities. Such by-laws shall also provide the fees of admission, dues and assessments to be paid by the members and the grounds for and the manner in which members may withdraw, be suspended or expelled.

- - -

Article XI is hereby amended to read as follows:

These Articles of Incorporation may be amended at any meeting of the members called for that purpose (by the Board of Directors or by at least one hundred (100) members of this Corporation who petition for such a meeting), by an affirmative vote of a majority of the members of the corporation present at the meeting. Notice of any proposed amendment or amendments shall be given by written notice to the directors at least ten (10) days prior to a regular Board meeting, and by publication once a week for two consecutive weeks prior to the Corporation membership meeting, in a newspaper or newspapers of general circulation in the county wherein the Articles of Incorporation were published; and by posting on the Town Hall bulletin boards two weeks prior to the Corporation membership meeting.

September 11, 1967

FELLOW MEMBERS OF TOWN HALL:

Since Town Hall was incorporated in 1963, a great many changes have occurred and the by-laws which sufficed then, when Del Webb operated Town Hall, don't do a job for us now. Today we are three times as big as then, with over a million dollars in property and it takes a six-figure budget to run the place. So we must update our by-laws to fit our present operation with a full time professional manager.

Your By-Laws Revision Committee - Phil Campbell, Earl Holmes, George Jacobs, Art Mathis, Chris Nelson, Lin Price, Clyde Wells and Jack Jackley, chairman - has compiled a revised set of By-Laws which fully comply with our own Articles of Incorporation and with the Arizona Code, and which provide a vehicle for the smooth, efficient and economical operation of Town Hall in all its aspects. Here are the salient features:

Almost any corporation you can name - profit making or non-profit, from General Motors to our own local Home Owners' Association - votes for its directors and they, in turn, choose the officers. Under the proposed by-laws, Town Hall will adopt this standard procedure.

A professional manager to operate all facilities will be responsible to the Board thru the President, who is also required to appoint a Finance-Budget Committee to guard the finances, a Properties Committee to maintain constant vigilance over our physical properties, and a Committee on Committees to safeguard the nominating procedure of all candidates for the Board. No member of the Board may serve on the Nominating Committee.

Under current by-laws the recognized clubs name all candidates for the Nominating Committee; the new by-laws provide that only five members of this committee shall be chosen from names submitted by the clubs, and the other four members shall be chosen from the membership at large by the Committee on Committees.

At the tabulation of votes, the current by-laws permit as observers only persons designated by the clubs. The revised by-laws will allow any member of Town Hall in good standing to be an observer. The section on amendments to by-laws is now in full conformity with our own Articles of Incorporation and with the Arizona Code governing such matters.

Amendments to the Articles of Incorporation (see back of last page) cover the 2-year term for directors which was voted overwhelmingly last winter; the change-over to the system of voting for directors who will choose their own officers; and certain specific wording in Article XI which is necessary to conform to the Arizona Code.

We hope all of you will take time between now and September 25 to read over the entire set of proposed revisions and amendments and familiarize yourselves with them. Then, if you have any questions, drop in at the office at 10600 Peoria Avenue any day - Monday thru Friday - 10 a.m. to 4 p.m., and a member of the By-Laws Committee will be there to discuss such items with you.

These Articles of Incorporation, as amended, and the Revised By-Laws were submitted by the By-Laws Committee and approved by the Board of Directors at a special meeting called for that purpose at Town Hall Center on Monday, August 21, 1967; and will be presented to the Town Hall members to be voted on at 1:30 p.m. Monday, September 25, 1967, in the new Town Hall South auditorium. Come and bring your neighbor (and be sure both of you bring along your Town Hall membership cards to provide identification for voting).

BOARD OF DIRECTORS
SUN CITY TOWN HALL CENTER

September 11, 1967

FELLOW MEMBERS OF TOWN HALL:

Since Town Hall was incorporated in 1963, a great many changes have occurred and the by-laws which sufficed then, when Del Webb operated Town Hall, don't do a job for us now. Today we are three times as big as then, with over a million dollars in property and it takes a six-figure budget to run the place. So we must update our by-laws to fit our present operation with a full time professional manager.

Your By-Laws Revision Committee - Phil Campbell, Earl Holmes, George Jacobs, Art Mathis, Chris Nelson, Lin Price, Clyde Wells and Jack Jackley, chairman - has compiled a revised set of By-Laws which fully comply with our own Articles of Incorporation and with the Arizona Code, and which provide a vehicle for the smooth, efficient and economical operation of Town Hall in all its aspects. Here are the salient features:

Almost any corporation you can name - profit making or non-profit, from General Motors to our own local Home Owners' Association - votes for its directors and they, in turn, choose the officers. Under the proposed by-laws, Town Hall will adopt this standard procedure.

A professional manager to operate all facilities will be responsible to the Board thru the President, who is also required to appoint a Finance-Budget Committee to guard the finances, a Properties Committee to maintain constant vigilance over our physical properties, and a Committee on Committees to safeguard the nominating procedure of all candidates for the Board. No member of the Board may serve on the Nominating Committee.

Under current by-laws the recognized clubs name all candidates for the Nominating Committee; the new by-laws provide that only five members of this committee shall be chosen from names submitted by the clubs, and the other four members shall be chosen from the membership at large by the Committee on Committees.

At the tabulation of votes, the current by-laws permit as observers only persons designated by the clubs. The revised by-laws will allow any member of Town Hall in good standing to be an observer. The section on amendments to by-laws is now in full conformity with our own Articles of Incorporation and with the Arizona Code governing such matters.

Amendments to the Articles of Incorporation (see back of last page) cover the 2-year term for directors which was voted overwhelmingly last winter; the change-over to the system of voting for directors who will choose their own officers; and certain specific wording in Article XI which is necessary to conform to the Arizona Code.

We hope all of you will take time between now and September 25 to read over the entire set of proposed revisions and amendments and familiarize yourselves with them. Then, if you have any questions, drop in at the office at 10600 Peoria Avenue any day - Monday thru Friday - 10 a.m. to 4 p.m., and a member of the By-Laws Committee will be there to discuss such items with you.

These Articles of Incorporation, as amended, and the Revised By-Laws were submitted by the By-Laws Committee and approved by the Board of Directors at a special meeting called for that purpose at Town Hall Center on Monday, August 21, 1967; and will be presented to the Town Hall members to be voted on at 1:30 p.m. Monday, September 25, 1967, in the new Town Hall South auditorium. Come and bring your neighbor (and be sure both of you bring along your Town Hall membership cards to provide identification for voting).

BOARD OF DIRECTORS
SUN CITY TOWN HALL CENTER

VF - RECREATION CENTERS - FAIRWAY (TOWN HALL)

AMENDMENTS TO THE ARTICLES OF INCORPORATION
 (As Amended Sept. 25, 1967)
 SUN CITY TOWN HALL CENTER

SUN CITY, ARIZONA

Article VII is hereby amended to read as follows:

The affairs of the Corporation shall be conducted by a Board of Directors and such officers as the Board may elect or appoint. The number of Directors shall not be less than three (3) nor more than twenty-five (25), and shall be elected by the members at the annual meeting of the members of the Corporation, to be held on the first Thursday in December of each year, beginning with 1963; provided, however, that such date may be changed from time to time by the Board of Directors. The Directors shall be elected for a term of two (2) years. The following directors shall continue to serve until the annual Corporation membership meeting to be held on the first Thursday in December, 1968: Mrs. Bertha Cox, George H. Jacobs, John W. Prather, Alfred R. Voelker. All directors shall serve until their successors are elected and qualified; and shall elect annually from their own number the four officers for the current year.

The directors, subject to approval or veto by the members of the Corporation, shall have the power to adopt By-Laws for the Corporation. The By-Laws may be amended, modified, revised or revoked by the directors or by the members. In the event of conflict concerning the By-Laws as amended, modified, revised or revoked by the directors, the action of the members shall prevail. The procedure for the changing of any by-laws shall conform to and be consistent with the procedural method outlined in Article XI of the Articles of Incorporation.

The directors shall have power to fill vacancies occurring in the board or in any office, subject to approval or veto by the members. The Board may appoint from its own number an executive committee and invest such committee with such powers as may be approved by the directors.

The by-laws of the Corporation shall prescribe the qualifications of members and the terms of admission to membership, provided that the voting rights of all active members shall be equal and all active members shall have equal rights and privileges and be subject to equal responsibilities. Such by-laws shall also provide the fees of admission, dues and assessments to be paid by the members and the grounds for and the manner in which members may withdraw, be suspended or expelled.

- - -

Article XI is hereby amended to read as follows:

These Articles of Incorporation may be amended at any meeting of the members called for that purpose (by the Board of Directors or by at least one hundred (100) members of this Corporation who petition for such a meeting), by an affirmative vote of a majority of the members of the corporation present at the meeting. Notice of any proposed amendment or amendments shall be given by written notice to the directors at least ten (10) days prior to a regular Board meeting, and by publication once a week for two consecutive weeks prior to the Corporation membership meeting, in a newspaper or newspapers of general circulation in the county wherein the Articles of Incorporation were published; and by posting on the Town Hall bulletin boards two weeks prior to the Corporation membership meeting.

- (b) These By-Laws may be amended at any meeting of the members called for that purpose (by the Board of Directors or by at least one hundred (100) members of this Corporation who petition for such meeting) by an affirmative vote of a majority of the members present at the meeting. Notice of any proposed amendmat or amendments shall be given by written notice to the Directors at least ten (10) days prior to a regular Board meeting, and by publication once a week for two consecutive weeks prior to the Corporation membership meeting, in a newspaper or newspapers of general circulation in the county wherein the Articles of Incorporation were published, and by posting upon the Town Hall bulletin boards two weeks prior to the Corporation membership meeting.
- (c) Voting procedures outlined in Article IX shall apply.

ARTICLE XI - RESTRICTION

SECTION 1. No Article, Section or Sub-Section in these By-Laws shall be in conflict with the Articles of Incorporation, as amended.

BY-LAWS
(As Revised Sept. 25, 1967)

SUN CITY TOWN HALL CENTER
(Hereinafter known as "Town Hall")

ARTICLE I - OFFICE

The principal office for the transaction of business of Town Hall shall be located in Sun City, Arizona.

ARTICLE II - MEMBERSHIP

SECTION 1. (a) Members shall be homeowners and/or residents occupying a house or apartment which is located as designated in the Articles of Incorporation, as amended. Residents of Sun Valley Lodge who were members in good standing at the time of moving to the Lodge may continue their memberships by payment of the current annual assessments.

(b) Membership shall not be transferable.

(c) A member must be current in the payment of the annual assessments to validate the membership and to entitle the member to all rights and privileges of same.

SECTION 2. (a) Privileges of members shall be to vote, to hold office, to use all available facilities, subject to the rules and regulations of Town Hall or approved for the chartered clubs, and to participate and become members of all activities and clubs of Town Hall. Members shall have certain guest privileges as provided in the "Rules and Regulations".

(b) No member shall be denied the use of any facilities of Town Hall even though he has no membership in any chartered club, and no chartered club shall have any rule or regulation, except those for the safety of persons and/or protection of property, prohibiting the use of any facility by such member.

(c) No member or group of members, whether or not sponsored by a chartered club, or any other person or persons, shall so conduct themselves in or on Town Hall property as to jeopardize the rights and privileges of other Town Hall members, their guests or any other person or persons. A cease and desist order shall be issued by the Town Hall Board of Directors against such infractions and, upon failure of such infractors to comply with said order, denial of the use of Town Hall property for such practices shall be ordered by the Board.

SECTION 3. (a) The assessments for all members for each fiscal year (January 1 through December 31) shall be determined by the Board of Directors of this Corporation. Such assessments shall be due and payable January 1st of each year. Payment will entitle each member to a card which is valid in all Town Hall facilities. If membership should be established during the fiscal year, the assessment shall be prorated on a monthly basis until the end of the current fiscal year.

(b) An admission fee of one hundred (100) dollars shall be charged any person who delays more than six (6) months in applying for membership after becoming eligible for same. A re-admission fee of one hundred (100) dollars may be charged for restoration to membership after default of membership due to delinquency of six (6) months in the payment of assessments due, or after withdrawal from membership.

SECTION 4. (a) A membership may be suspended or the member expelled by the Board of Directors, after a hearing by the Board, for non-compliance by such member with the provisions of the Articles, By-Laws, Rules and Regulations.

(b) Application for reinstatement may be filed with the Board of Directors after such suspension or expulsion has been effective for thirty (30) days. During the period of suspension or expulsion such member shall have no rights to utilize any of the facilities of Town Hall.

SECTION 5. (a) Quarterly corporation membership meetings shall be held each year on the second Monday during the months of January, May, September and November. The annual corporation membership meeting shall be held on the first Thursday in December, at which time the election will be held for the directorships.

(b) One hundred (100) members may file a request with the Secretary of the Board of Directors for a special meeting, stating the reasons for the meeting. Within ten (10) days after receiving such request, the President shall call a special meeting to be held within thirty (30) days. A quorum for any meeting shall consist of not less than one hundred (100) members and Roberts' Rules of Order, Revised, shall prevail, except as provided in the By-Laws. A quorum shall be presumed in the absence of a challenge.

ARTICLE III - BOARD OF DIRECTORS

SECTION 1. There shall be nine (9) directors, including the officers, none of whom shall receive compensation of any kind for his service to the Corporation. At the regular Board meeting in January of each year the newly elected directors shall be installed and the members of the Board shall then select from their own number the four officers listed in Article IV, who shall serve during that calendar year and until their successors are chosen and installed.

SECTION 2. At the first meeting of the Board of Directors a temporary chairman shall be appointed and the first order of business at this meeting shall be the election of officers. Election procedure shall be as follows:

Each member of the Board of Directors shall be given a list of all directors, alphabetically arranged.

Each director shall mark on his list his choice for President, for Vice-President, for Secretary and for Treasurer.

A committee of tellers appointed by the temporary chairman shall collect and tally the votes as indicated on these lists and the temporary chairman shall, upon receiving the tally, announce the results and shall declare the one receiving the most votes for each office duly elected to that office to serve during the current year or until a successor has been elected and qualified.

Whereupon the temporary chairman shall turn the meeting over to the newly elected President.

SECTION 3. Term of office. All directors shall be elected for a two-year term; four being elected in each even-numbered year and five in each odd-numbered year.

SECTION 4. Regular meetings shall be at Town Hall on the first Monday of each month at 9:00 AM, unless otherwise specified by the President, who shall preside at all meetings. Two-thirds of the members of the Board shall constitute a quorum. All meetings shall be conducted in accordance with the By-Laws and Roberts' Rules of Order, Revised, except as provided in the By-Laws.

SECTION 5. The Board of Directors shall hold and administer the assets, and shall direct, control, manage, and supervise the business and affairs of the Corporation.

SECTION 6. The Board of Directors shall have authority to make rules and regulations as deemed expedient and within the authority as outlined in the Articles of Incorporation and the By-Laws as amended. There shall be copies of the complete Rules and Regulations available to all members of Town Hall in the Town Hall offices at all hours when such offices are open for business, but such copies may not be removed from the premises.

SECTION 7. The Board of Directors shall have the authority to hire a manager and such other employees as are deemed necessary for the proper operation of Town Hall and its facilities, including the authority to dismiss such employees when deemed advisable. The manager's principal duties are as outlined in the Rules and Regulations, but the Board of Directors shall have authority to prescribe such additional duties for the manager as may be required for the best operation of Town Hall. The manager shall report through the President to the Board of Directors. The manager shall give a complete written report of the state of affairs concerning the operation of Town Hall at each regular monthly meeting of the Board of Directors, and to the members at each quarterly Corporation meeting.

ARTICLE IV - OFFICERS

SECTION 1. The officers of the Corporation shall be President, Vice-President, Secretary, and Treasurer.

SECTION 2. President. The President shall be Chairman of the Board of Directors and shall preside at and conduct all meetings by a formal order of business. He shall have general supervision and direction of the affairs of the Corporation in accordance with the Articles of Incorporation and the By-Laws, shall have authority to administer all matters not otherwise expressly delegated, shall appoint all committees (with the consent and approval of the Board) except the Nominating and Balloting Committees, and shall call all special meetings of the Corporation and/or the Board of Directors.

SECTION 3. Vice-President. The Vice-President shall perform the duties of the President during the latter's absence.

SECTION 4. Secretary. The Secretary shall keep a record of the minutes of the meetings, shall send out notices of meetings and shall keep the members informed by bulletins from time to time as occasion warrants and shall perform such other duties as ordinarily pertain to that office.

SECTION 5. (a) Treasurer. The Treasurer shall be the custodian of all funds of the Corporation and shall collect and disburse the same and keep a financial record thereof as prescribed by the Board of Directors, and deposit them to the account of Sun City Town Hall Center in the bank or banks designated by the Board of Directors; shall sign all checks which shall be countersigned by the President or such other officers or Board members as may be designated by the Board of Directors; shall issue financial statements when required, including regularly scheduled Corporation meetings, and perform such other duties as ordinarily pertain to that office. His financial records shall be audited at the close of the fiscal year by a certified public accountant, as selected by the Board of Directors.

(b) The Board of Directors may appoint an assistant treasurer to serve at the discretion of the Board. Such assistant treasurer shall, in the absence or incapacity of the Treasurer, have the powers, duties, and the responsibilities of the Treasurer, but shall receive no compensation therefor.

SECTION 6. All officers, Board members, Committee chairmen and members, and employees who are in any way involved in the handling of Corporation funds, and the paid manager of the Corporation, shall be bonded in a sum to be determined by the Board of Directors.

SECTION 7. The term of office of all officers shall be one year, as provided in Section 1 of Article III. Elected officers shall serve until their successors are duly elected and installed.

ARTICLE V - VACANCIES

SECTION 1. Removal. Action for removal of any elected officer or member of the Board of Directors may be initiated by not less than one hundred (100) members of the Corporation, who shall submit their reasons in writing to the Secretary. The request for recall shall be publicized for not less than twenty-six (26) days, after which and within seven (7) days the members of the Corporation may vote on the recall by secret ballot, according to Article IX of these By-Laws. An affirmative vote equal to two-thirds of all votes cast at the last annual election in December shall be necessary for the recall of an elected officer or Board member.

SECTION 2. Vacancy. The Board of Directors may declare vacant the position of any officer or director who, without good and sufficient reasons acceptable to the remaining members of the Board, is absent from three or more consecutive regular meetings of the Board.

SECTION 3. Replacement. A vacancy on the Board of Directors, or in any office, because of death, resignation, removal, disqualification or otherwise, shall be filled by the Board of Directors by appointment of a member of the Corporation to serve for the unexpired term of his predecessor, subject to the approval of the members of the Corporation at the next quarterly Corporation meeting.

ARTICLE VI - COMMITTEES

SECTION 1. (a) The President shall be empowered to appoint, with the consent and approval of the Board, such committees as he may deem necessary to properly and effectively carry on the affairs of the Corporation, but it shall be mandatory, at the next regular board meeting after election of the President, that a Finance-Budget Committee, a Properties Committee, and a Committee on Committees of not less than five (5) nor more than nine (9) members, with a member of the Board as chairman of each, be included in these appointments. This authority shall include all committees, standing and special, except the Nominating and Balloting Committees which are specifically provided for in Articles VIII and IX, respectively, of these By-Laws.

(b) FINANCE-BUDGET COMMITTEE - Will have general control of the financial policy, subject to the approval of the Board of Directors, including ways and means for obtaining funds necessary to meet the authorized budget for carrying out the work of the Corporation. Will present in writing, not later than December 15 of each year, an itemized estimate of the income and expenses for the ensuing year which, upon approval of the Board of Directors, shall become the authorized budget for that year, and no obligation beyond the amount thus authorized shall be incurred by any committee or agent of the Corporation unless specially authorized by the Board of Directors. The Rules and Regulations shall outline methods for periodic audits and inventory checks by this committee.

(c) PROPERTIES COMMITTEE - Will be composed of members particularly skilled in the various technical requirements to function properly. This committee shall conduct at least once every sixty (60) days a complete inspection of all the Town Hall physical properties, including the buildings, equipment and grounds, to determine if same are safe, are being properly cared for, and are in good condition. After each inspection, the chairman shall make a report in writing to the Board of Directors of the status of the facilities, including any recommendations that may be necessary for the better preservation and care of the facilities, or replacements of equipment as needed. The Committee shall have no other authority.

(d) COMMITTEE ON COMMITTEES - Will recommend qualified persons to the President for committee membership, and conduct nominating procedure as outlined in Article VIII of these By-Laws.

ARTICLE VII - CHARTERED CLUBS

SECTION 1. A chartered Town Hall club is one approved by the Board of Directors. Requirements for chartering, as well as the duties, responsibilities and authorities of such clubs are outlined in the "Club Organization" section of the Rules and Regulations. There shall be no conflict of club rules and regulations with the Articles of Incorporation and/or the By-Laws, and/or Rules and Regulations of this Corporation, as amended. These Club Rules and Regulations shall be posted at all times on the Town Hall bulletin boards and will be available to all clubs and organizations and individuals using Town Hall facilities.

ARTICLE VIII - NOMINATION PROCEDURE

SECTION 1. A Nominating Committee of nine (9) members shall make nominations at the Corporation membership meeting in November of each odd-numbered year for the five (5) directors of the Board to be elected in that year; and in each even-numbered year for the four (4) directors to be elected in that year.

SECTION 2. The Nominating Committee shall consist only of Town Hall residents, who are members in good standing, to be chosen as follows:

(a) Not later than September 15 of each year, each chartered Town Hall club shall submit in writing the name of one of its members to the Chairman of the Committee on Committees, for consideration as a member of the Nominating Committee.

(b) The Committee on Committees shall transmit to the Board of Directors not later than October 1, at least fifteen (15) of the submitted names.

(c) The Board of Directors, at their regular October meeting, shall select five (5) names from the list submitted and, in addition, the Committee on Committees shall select four (4) names to represent the membership at large. These nine (9) persons shall serve as the Nominating Committee and the Board shall arrange appropriate announcement of the same.

(d) The President shall call the first meeting of the Nominating Committee, at which time he will outline the duties and responsibilities of the Committee. The Committee will elect its chairman and the President will then retire from the meeting place.

SECTION 3. The Nominating Committee shall prepare a slate of not less than two (2) persons for each board seat to be filled at the upcoming election. This slate and any nominations from the floor at the November meeting shall be publicized in the same manner as for amending the Articles of Incorporation and shall be posted by listing the names of the nominees in alphabetical order on the official bulletin boards immediately after the slate has been announced at the November meeting. Announcement shall also be made at this meeting of the hours and place for voting.

SECTION 4. A candidate and/or nominee must be a Town Hall member in good standing and a resident of the Town Hall area. Any member of the Nominating Committee, if requested by the Committee, may be nominated. Any person nominated shall declare his availability for attendance at necessary meetings of the Board and shall make himself available for any office to which the Board may elect him.

SECTION 5. There shall be no members of the Board on the Nominating Committee.

ARTICLE IX - VOTING PROCEDURE

SECTION 1. A voice or standing vote or show of hands shall prevail on all matters of business, except as follows when a secret ballot will be required:

- (a) The election of all directors.
- (b) Recall of any officer and/or any member of the Board of Directors.
- (c) When a majority of the Board of Directors request a secret ballot.
- (d) When a secret ballot is requested by a majority vote of the eligible members of the Corporation at any meeting.

SECTION 2. When a secret ballot is required on (a), (b), or (c) above, the following will apply:

- (a) The subject shall be voted on in direct accordance with the procedures as outlined in Articles VII or XI of the Articles of Incorporation as they may apply.
- (b) Voting shall proceed under supervision of the Balloting Committee composed of five (5) members of the Board of Directors appointed by the Board. No nominee may serve on or assist the Balloting Committee. Ballot boxes and election procedure shall be prepared by this Committee.
- (c) At least two (2) members of the Balloting Committee shall be in attendance at all times during voting and they shall determine eligibility (Article II of the By-Laws) of all voters, issue all official ballots and witness the casting of the ballots.
- (d) Ballot boxes shall remain sealed until all votes are cast, then opened and votes tabulated in the presence of at least three (3) members of the Balloting Committee. Upon completion of the tabulation of ballots, the results shall be certified by balloting chairman to the Board and officially posted on Town Hall bulletin boards.
- (e) Any Town Hall member may be present as an observer at the tabulation of votes.

- SECTION 3.
- (a) An eligible voter (Article II of By-Laws) if he will be absent from Maricopa County on the date set for balloting, may cast an absentee ballot at the place or time, or by mail, as designated by the Balloting Committee, but not more than fourteen (14) days nor less than three (3) days prior to the voting date.
 - (b) When requested by an ill or incapacitated eligible voter (Article II of By-Laws) not more than five days nor less than two days prior to the voting date, any two members of the Balloting Committee shall take an official ballot and a sealed ballot box to his home and witness the casting of his absentee ballot.
 - (c) Ballot boxes containing absentee votes shall be opened and the ballots tabulated at the same time and place and under the same conditions as the regular ballots.
 - (d) Following tabulation, all ballots will be sealed and stored for a period of thirty (30) days, in custody of the Board of Directors.

ARTICLE X - AMENDMENTS

SECTION 1. (a) Action on changes and/or amendments to the By-Laws may be initiated by the Board of Directors or by petition of at least one hundred (100) members of the Corporation. These By-Laws may be amended, modified, revised or revoked by the Board of Directors or by the members, but such action by the Board shall be subject to approval by vote of the members at the first quarterly Corporation membership meeting following such Board action, or at a meeting called for that purpose.

May 9, 1967

TO ALL MEMBERS OF SUN CITY TOWN HALL CENTER:

In the January Corporation meeting for Town Hall members, we outlined certain important things we expected to do in 1967. The FIRST AND MOST IMPORTANT was to appoint a special committee to study our entire operation and to recommend such revisions of our By-Laws as will provide a business-like, modern and efficient set of standards for the operation of Town Hall Center.

It is hard to realize, but within the next few months when we take over all the new facilities being built for us under our contract with Del E. Webb Development Company, Town Hall Center will own and operate approximately a MILLION DOLLARS worth of facilities and will have nearly six thousand members.

THIS IS NO LONGER A SMALL ENTERPRISE, but one requiring professional, paid management and operation to provide all of the constantly increasing services that are desired and required by the many members and organizations using the facilities.

Because of the many weaknesses, conflicts and omissions of our present By-Laws, over four month's study was made and as a result, on April 26, 1967, the Town Hall Board approved a complete new revision of our By-Laws. On May 8, 1967, these were presented in detail to the members at the regular Corporation meeting at Town Hall.

MONDAY, JUNE 5, 1967 was officially set as the date on which these By-Laws are to be voted on by the Town Hall members. So that each Town Hall member can be familiar with the new By-Laws, we are attaching them to this announcement and briefly giving you a few reasons why these new By-Laws are necessary.

In 1963, when Sun City Town Hall Corporation was formed and most of our present By-Laws were written, the entire Town Hall Center facilities were owned, operated and maintained by the Del E. Webb Development Company, who collected the membership fees, paid the bills and operated under their own Corporation Articles, by-laws, rules, etc. There were only some ten or eleven clubs, the total membership comparatively small, and the demands for facilities likewise. The Town Hall By-Laws primarily dealt with and were used in governing the Club operations and advisory aspects only.

And yet, on January 1, 1965, when these facilities were deeded over to the Sun City Town Hall Center and the members became solely responsible for its operation, those same Town Hall By-Laws had to be used to govern Town Hall, and its unpaid members were required to manage and operate the entire facilities. In 1965, as in the rapidly growing year of 1966, members of the Board and the Town Hall committees, who, you must remember, were serving without pay, found it had become an increasingly demanding job to run Town Hall and that the By-Laws did not spell out any provisions or rules for a paid manager and employee type operation. Believe us, it was only because of the many hours and intelligent work put in by such dedicated people as Lan Atkins, Chairman of the 1965 House Committee, and Clyde Wells, who held the same job in 1966, and others serving on the Board and Committees, that the job got done. Week after week, they put as much or more time in for Town Hall than they had on their jobs before retiring. This was asking too much from people who came here to retire.

As a result, in the spring of 1966, a professional manager was hired to run the physical operations of Town Hall, and for the first time under Town Hall ownership, the Board came face to face with the necessity for devising a set of rules spelling out the responsibilities and authority of a paid manager. Believe it or not, there was not one word in the entire By-Laws that mentioned an employee or provided any guide for the manager or operation with paid employees -- remember, prior to 1965, the Webb Company ran it themselves with their own manager and paid employees.

Space does not permit outlining all of the many other reasons for the new By-Laws, but many of them are self-explanatory, and these By-Laws, together with the Rules and Regulations mentioned, are contained in several books available for your inspection in the Town Hall offices.

SUN CITY TOWN HALL CENTER
BOARD OF DIRECTORS

BY-LAWS
(as amended)
SUN CITY TOWN HALL CENTER
(Hereinafter known as "Town Hall")

ARTICLE I - OFFICE

The principal office for the transaction of business of Town Hall shall be located in Sun City, Arizona.

ARTICLE II - MEMBERSHIP

SECTION 1. (a) Members shall be homeowners and/or residents occupying a house or apartment which is located as designated in the Articles of Incorporation.

(b) Membership shall not be transferable.

(c) A member must be current in the payment of the annual assessments to validate the membership and to entitle the member to all rights and privileges of same.

SECTION 2. (a) Privileges of members shall be to vote, to hold office, to use all available facilities, subject to the rules and regulations of Town Hall or approved for the chartered clubs, and to participate and become members of all activities and clubs of Town Hall. Members shall have certain guest privileges as provided in the "Rules and Regulations".

(b) No member shall be denied the use of any facilities of Town Hall even though he has no membership in any chartered club, and no chartered club shall have any rule or regulation, except those for the safety of persons and/or protection of property, prohibiting the use of any facility by such member.

(c) No member or group of members, whether or not sponsored by a chartered club, or any other person or persons, shall so conduct themselves in or on Town Hall property as to violate any local, county, state or federal law and/or jeopardize the rights and privileges of other Town Hall members, their guests or any other person or persons. A cease and desist order shall be issued by the Town Hall Board of Directors against such infractions and, upon failure of such infractors to comply with said order, denial of the use of Town Hall property for such practices shall be ordered by the Board.

SECTION 3. (a) The assessments for all members for each fiscal year (January 1 through December 31) shall be determined by the Board of Directors of this Corporation. Such assessments shall be due and payable January 1st of each year. Payment will entitle each member to a card which is valid in all Town Hall facilities. If home ownership should be established during the fiscal year, the assessment shall be prorated on a monthly basis until the end of the current fiscal year.

(b) An admission or re-admission fee of one hundred (100) dollars for application or restoration to membership after a delinquency of six (6) months in the payment of assessments due, or after withdrawal from membership, shall obtain.

SECTION 4. (a) A membership may be suspended or the member expelled by the Board of Directors, after a hearing by the Board, for non-compliance by such member with the provisions of the Articles, By-Laws, Rules and Regulations.

(b) Application for reinstatement may be filed with the Board of Directors after such suspension or expulsion has been effective for thirty (30) days. During the period of suspension or expulsion such member shall have no rights to utilize any of the facilities of Town Hall.

SECTION 5. (a) Regular corporation membership meetings shall be held during the months of January, May, September and November, at a place, date and hour to be set by the Board of Directors.

(b) One hundred (100) members may file a request with the Secretary of the Board of Directors for a special meeting, stating the reasons for the meeting. The President shall call such a special meeting within ten (10) days after receiving such request. A quorum for any meeting shall consist of not less than one hundred (100) members and Roberts' Rules of Order, Revised, shall prevail, except as provided in the By-Laws. A quorum shall be presumed in the absence of a challenge.

ARTICLE III - OFFICERS

SECTION 1. The officers of the Corporation shall be President, Vice-President, Secretary, and Treasurer.

SECTION 2. President. The President shall be Chairman of the Board of Directors and shall preside at and conduct all meetings by a formal order of business. He shall have general supervision and direction of the affairs of the Corporation in accordance with the By-Laws, shall have authority to administer all matters not otherwise expressly delegated, shall appoint all committees (with the consent and approval of the Board) except the Nominating, Balloting and Executive Committees, and shall call all special meetings of the Corporation and/or the Board of Directors.

SECTION 3. Vice-President. The Vice-President shall perform the duties of the President during the latter's absence.

SECTION 4. Secretary. The Secretary shall keep a record of the minutes of the meetings; shall send out notices of meetings and shall keep the members informed by bulletins from time to time as occasion warrants and shall perform such other duties as ordinarily pertain to that office.

SECTION 5. Treasurer. The Treasurer shall be the custodian of all funds of the Corporation and shall collect and disburse the same and keep a financial record thereof as prescribed by the Board of Directors and deposit them in the bank or banks designated by the Board of Directors; shall sign all checks which shall be countersigned by the President or such other officers or Board members as may be designated by the Board of Directors; shall issue financial statements when required and perform such other duties as ordinarily pertain to that office.

SECTION 6. All officers, Board members, Committee chairmen and members, and employees who are in any way involved in the handling of Corporation funds, and the paid manager of

the Corporation, shall be bonded in a sum to be determined by the Board of Directors.

SECTION 7. Term of office. The term of office of all elected officers shall be one year. Elected officers shall serve until their successors are duly elected and installed.

ARTICLE IV - BOARD OF DIRECTORS

SECTION 1. There shall be eleven (11) directors, including the four elected officers, none of whom shall receive a salary for his service to the Corporation.

SECTION 2. The four officers shall be elected annually; the other seven directors shall be elected for two year terms, three of them being elected in odd-numbered years, four in even-numbered years.

SECTION 3. Regular meetings shall be at Town Hall on the first Monday of each month at 9:00 AM, unless otherwise specified by the President, who shall preside at all meetings. Two-thirds of the members shall constitute a quorum. All meetings shall be conducted in accordance with the By-Laws and Roberts' Rules of Order, Revised, except as provided in the By-Laws.

SECTION 4. The Board of Directors shall hold and administer the assets, and shall direct, control, manage, and supervise the business and affairs of the Corporation.

SECTION 5. The Board of Directors shall have authority to make rules and regulations as deemed expedient and to incorporate in the By-Laws such rules and regulations by reference.

ARTICLE V - VACANCIES

SECTION 1. Removal. Action for removal of any elected officer or member of the Board of Directors may be initiated by not less than one hundred (100) members of the Corporation, who shall submit their reasons in writing to the Secretary. The request for recall shall be publicized for not less than twenty-six (26) days, after which and within seven (7) days the members of the Corporation may vote on the recall by secret ballot, according to Article IX of these By-Laws and the Rules and Regulations. Two-thirds of all votes cast at the last annual election in December shall be necessary for the recall of an elected officer or Board member.

SECTION 2. Vacancy. The Board of Directors may declare vacant the position of any officer or director who, without good and sufficient reasons acceptable to the remaining members of the Board, is absent from three or more consecutive regular meetings of the Board.

SECTION 3. Replacement. A vacancy on the Board of Directors or in any office, because of death, resignation, removal, disqualification or otherwise, shall be filled by the Board of Directors, subject to the approval of the members of the Corporation, by appointment of a member of the Corporation to serve until the next annual election. A director appointed to fill a vacancy shall serve for the unexpired term of his predecessor.

ARTICLE VI - COMMITTEES

SECTION 1. The President shall be empowered to appoint, with the consent and approval of the Board, such committees as he may deem necessary to properly and effectively carry on the affairs of the Corporation. This authority shall include all committees, standing and special, except the Nominating, Balloting, and Executive committees, which are specifically provided for in Articles VIII and IX of these By-Laws and/or the Rules and Regulations.

ARTICLE VII - CHARTERED CLUBS

SECTION 1. A chartered Town Hall club is one approved by the Board of Directors. Requirements for chartering, as well as the duties, responsibilities and authorities of such clubs are outlined in the "Club Organization" section of the Rules and Regulations. There shall be no conflict of club rules and regulations with the Articles of Incorporation and/or the By-Laws, and/or Rules and Regulations of this Corporation.

ARTICLE VIII - NOMINATION PROCEDURE

SECTION 1. The Nominating Committee shall submit a slate of officers and directors for consideration by the Board of Directors, consisting of at least two (2) candidates for each of the offices and director openings in accordance with approved procedure in the Rules and Regulations.

SECTION 2. The slate shall be announced at the regular November meeting of the Corporation and thereafter published and posted.

SECTION 3. The Board of Directors shall set the date and conduct the election in December not later than the 15th of that month.

ARTICLE IX - VOTING PROCEDURE

SECTION 1. Voting on all matters of business, whether by secret ballot or otherwise, shall be in accordance with the procedure as specified in the Rules and Regulations.

ARTICLE X - AMENDMENTS

SECTION 1. (a) Action on changes and/or amendments to the By-Laws may be initiated by the Board of Directors or by petition of at least one hundred (100) members of the Corporation. These By-Laws may be amended, modified or revoked by the Board of Directors or by the members, but such action by the Board shall be subject to approval by vote of the members at the first regular Corporation membership meeting following such Board action.

(b) In cases where the members initiate the action or where the Board submits the matter to a vote before making any changes and/or amendments, the proposed changes and/or amendments shall be given to the Board at least ten (10) days prior to a regularly scheduled meeting of the Corporation, at which meeting the proposed changes and/or amendments shall be read and voted upon.

(c) Voting shall be according to Article IX and the procedure outlined in the Rules and Regulations.

ARTICLE XI - RESTRICTION

SECTION 1. No Article, Section or Sub-section in these By-Laws shall be in conflict with the Articles of Incorporation.

May 8, 1967

ARTICLE I - OFFICE

The principal office for the transaction of business of Town Hall shall be located in Sun City, Arizona.

ARTICLE II - MEMBERSHIP

SECTION 1. (a) Members shall be homeowners and/or residents occupying a house or apartment which is located as designated in the Articles of Incorporation.

(b) Membership shall not be transferable.

(c) A member must be current in the payment of the annual assessments to validate the membership and to entitle the member to all rights and privileges of same.

SECTION 2. (a) Privileges of members shall be to vote, to hold office, to use all available facilities, subject to the rules and regulations of Town Hall or approved for the chartered clubs, and to participate and become members of all activities and clubs of Town Hall. Members shall have certain guest privileges as provided in the "Rules and Regulations".

(b) No member shall be denied the use of any facilities of Town Hall even though he has no membership in any chartered club, and no chartered club shall have any rule or regulation, except those for the safety of persons and/or protection of property, prohibiting the use of any facility by such member.

(c) No member or group of members, whether or not sponsored by a chartered club, or any other person or persons, shall so conduct themselves in or on Town Hall property as to violate any local, county, state or federal law and/or jeopardize the rights and privileges of other Town Hall members, their guests or any other person or persons. A cease and desist order shall be issued by the Town Hall Board of Directors against such infractions and, upon failure of such infractors to comply with said order, denial of the use of Town Hall property for such practices shall be ordered by the Board.

SECTION 3. (a) The assessments for all members for each fiscal year (January 1 through December 31) shall be determined by the Board of Directors of this Corporation. Such assessments shall be due and payable January 1st of each year. Payment will entitle each member to a card which is valid in all Town Hall facilities. If home ownership should be established during the fiscal year, the assessment shall be prorated on a monthly basis until the end of the current fiscal year.

(b) An admission or re-admission fee of one hundred (100) dollars for application or restoration to membership after a delinquency of six (6) months in the payment of assessments due, or after withdrawal from membership, shall obtain.

SECTION 4. (a) A membership may be suspended or the member expelled by the Board of Directors, after a hearing by the Board, for non-compliance by such member with the provisions of the Articles, By-Laws, Rules and Regulations.

(OVER)

(b) Application for reinstatement may be filed with the Board of Directors after such suspension or expulsion has been effective for thirty (30) days. During the period of suspension or expulsion such member shall have no rights to utilize any of the facilities of Town Hall.

SECTION 5. (a) Regular corporation membership meetings shall be held during the months of January, May, September and November, at a place, date and hour to be set by the Board of Directors.

(b) One hundred (100) members may file a request with the Secretary of the Board of Directors for a special meeting, stating the reasons for the meeting. The President shall call such a special meeting within ten (10) days after receiving such request. A quorum for any meeting shall consist of not less than one hundred (100) members and Roberts' Rules of Order, Revised, shall prevail, except as provided in the By-Laws. A quorum shall be presumed in the absence of a challenge.

ARTICLE III - OFFICERS

SECTION 1. The officers of the Corporation shall be President, Vice-President, Secretary, and Treasurer.

SECTION 2. President. The President shall be Chairman of the Board of Directors and shall preside at and conduct all meetings by a formal order of business. He shall have general supervision and direction of the affairs of the Corporation in accordance with the By-Laws, shall have authority to administer all matters not otherwise expressly delegated, shall appoint all committees (with the consent and approval of the Board) except the Nominating, Balloting and Executive Committees, and shall call all special meetings of the Corporation and/or the Board of Directors.

SECTION 3. Vice-President. The Vice-President shall perform the duties of the President during the latter's absence.

SECTION 4. Secretary. The Secretary shall keep a record of the minutes of the meetings, shall send out notices of meetings and shall keep the members informed by bulletins from time to time as occasion warrants and shall perform such other duties as ordinarily pertain to that office.

SECTION 5. Treasurer. The Treasurer shall be the custodian of all funds of the Corporation and shall collect and disburse the same and keep a financial record thereof as prescribed by the Board of Directors and deposit them in the bank or banks designated by the Board of Directors; shall sign all checks which shall be countersigned by the President or such other officers or Board members as may be designated by the Board of Directors; shall issue financial statements when required and perform such other duties as ordinarily pertain to that office.

SECTION 6. All officers, Board members, Committee chairmen and members, and employees who are in any way involved in the handling of Corporation funds, and the paid manager of

the Corporation, shall be bonded in a sum to be determined by the Board of Directors.

SECTION 7. Term of office. The term of office of all elected officers shall be one year. Elected officers shall serve until their successors are duly elected and installed.

ARTICLE IV - BOARD OF DIRECTORS

SECTION 1. There shall be eleven (11) directors, including the four elected officers, none of whom shall receive a salary for his service to the Corporation.

SECTION 2. The four officers shall be elected annually; the other seven directors shall be elected for two year terms, three of them being elected in odd-numbered years, four in even-numbered years.

SECTION 3. Regular meetings shall be at Town Hall on the first Monday of each month at 9:00 AM, unless otherwise specified by the President, who shall preside at all meetings. Two-thirds of the members shall constitute a quorum. All meetings shall be conducted in accordance with the By-Laws and Roberts' Rules of Order, Revised, except as provided in the By-Laws.

SECTION 4. The Board of Directors shall hold and administer the assets, and shall direct, control, manage, and supervise the business and affairs of the Corporation.

SECTION 5. The Board of Directors shall have authority to make rules and regulations as deemed expedient and to incorporate in the By-Laws such rules and regulations by reference.

ARTICLE V - VACANCIES

SECTION 1. Removal. Action for removal of any elected officer or member of the Board of Directors may be initiated by not less than one hundred (100) members of the Corporation, who shall submit their reasons in writing to the Secretary. The request for recall shall be publicized for not less than twenty-six (26) days, after which and within seven (7) days the members of the Corporation may vote on the recall by secret ballot, according to Article IX of these By-Laws and the Rules and Regulations. Two-thirds of all votes cast at the last annual election in December shall be necessary for the recall of an elected officer or Board member.

SECTION 2. Vacancy. The Board of Directors may declare vacant the position of any officer or director who, without good and sufficient reasons acceptable to the remaining members of the Board, is absent from three or more consecutive regular meetings of the Board.

SECTION 3. Replacement. A vacancy on the Board of Directors or in any office, because of death, resignation, removal, disqualification or otherwise, shall be filled by the Board of Directors, subject to the approval of the members of the Corporation, by appointment of a member of the Corporation to serve until the next annual election. A director appointed to fill a vacancy shall serve for the unexpired term of his predecessor.

150 ER

ARTICLE VI - COMMITTEES

SECTION 1. The President shall be empowered to appoint, with the consent and approval of the Board, such committees as he may deem necessary to properly and effectively carry on the affairs of the Corporation. This authority shall include all committees, standing and special, except the Nominating, Balloting, and Executive committees, which are specifically provided for in Articles VIII and IX of these By-Laws and/or the Rules and Regulations.

ARTICLE VII - CHARTERED CLUBS

SECTION 1. A chartered Town Hall club is one approved by the Board of Directors. Requirements for chartering, as well as the duties, responsibilities and authorities of such clubs are outlined in the "Club Organization" section of the Rules and Regulations. There shall be no conflict of club rules and regulations with the Articles of Incorporation and/or the By-Laws, and/or Rules and Regulations of this Corporation.

ARTICLE VIII - NOMINATION PROCEDURE

SECTION 1. The Nominating Committee shall submit a slate of officers and directors for consideration by the Board of Directors, consisting of at least two (2) candidates for each of the offices and director openings in accordance with approved procedure in the Rules and Regulations.

SECTION 2. The slate shall be announced at the regular November meeting of the Corporation and thereafter published and posted.

SECTION 3. The Board of Directors shall set the date and conduct the election in December not later than the 15th of that month.

ARTICLE IX - VOTING PROCEDURE

SECTION 1. Voting on all matters of business, whether by secret ballot or otherwise, shall be in accordance with the procedure as specified in the Rules and Regulations.

ARTICLE X - AMENDMENTS

SECTION 1. (a) Action on changes and/or amendments to the By-Laws may be initiated by the Board of Directors or by petition of at least one hundred (100) members of the Corporation. These By-Laws may be amended, modified or revoked by the Board of Directors or by the members, but such action by the Board shall be subject to approval by vote of the members at the first regular Corporation membership meeting following such Board action.

(b) In cases where the members initiate the action or where the Board submits the matter to a vote before making any changes and/or amendments, the proposed changes and/or amendments shall be given to the Board at least ten (10) days prior to a regularly scheduled meeting of the Corporation, at which meeting the proposed changes and/or amendments shall be read and voted upon.

(c) Voting shall be according to Article IX and the procedure outlined in the Rules and Regulations.

ARTICLE XI - RESTRICTION

SECTION 1. No Article, Section or Sub-section in these By-Laws shall be in conflict with the Articles of Incorporation.

May 8, 1967

***** TOWN HALL CENTER BULLETIN *****

VOL I, NO. L

February 1, 1967

The Town Hall Center Board of Directors is initiating a new service to Town Hall members beginning with this - the first issue of a news bulletin - the Town Hall Center Bulletin.

The BULLETIN is to be issued each month as a means of getting current information about Town Hall Center and the Clubs to each member household.

The Town Hall clubs and other organized activities may use the BULLETIN to publicize their special programs, activities, and plans. It is hoped that all organizations will endeavor to promptly advise the BULLETIN of upcoming events so that Town Hall people will be informed about all special events and programs, and other news or information of particular or unusual interest.

For general information and convenience of Town Hall members, there are listed in this first issue of the BULLETIN, the Town Hall officers and Board members for 1967. The Town Hall committees, with all members, are listed, and the roster of the Town Hall clubs with the present chairmen is attached.

The Public Relations Committee of Town Hall Center is responsible for issuing this BULLETIN.

The editors of the BULLETIN believe this means of getting information to Town Hall members will be helpful and solicit comments and suggestions for improvement.

*		*
*	Future issues of this BULLETIN will look a lot different	*
*		*
*	if you cooperate with us in getting the news of your	*
*		-
*	organization to us by our 20th of the month deadline.	*
*		*
*	We want all of your news and feel that all Town Hall	*
*		*
*	members are interested and will participate more with	*
*		*
*	your programs if they know all about them.	*
*		*

***** TOWN HALL BULLETIN

VOL 2, No. 3

March 1, 1968

"May kindness and forbearance make
Sun City a glorious place,
Where each man feels a brotherhood
Unmarred by creed or race."

We have neither time nor space to comment on the many activities of the past weeks - Sun Bowl activities, social, civic, fraternal and many others, including the excellent work of our two Town Boards who are working so diligently toward an equitable consolidation of the two areas.

It seems 1968 promises to be the high-water mark for Sun City in facilities and activities, not only in home development, but bursting with activities in forty growing clubs, choruses, and other groups. We can't stop growth and progress when visitors "beat a path to our door" from as far away as Canada, Hawaii, and Alaska.

Musical and art programs are scheduled for the coming weeks - Liberace, chorus concerts, piano-organ concert, "The Play's the Thing", and many more listed in this Bulletin.

Better mark your March calendar now!!!

SQUARE DANCE CLUB - Change of location for one night only. Club to meet at club rooms at Peoria Avenue on March 29, 7:00 & 8:30 PM, instead of Town Hall South.

SUN CITY RETIRED TEACHERS' CLUB will meet Monday, March 18, 1:30 PM in the clubroom at the north west corner of Town Hall Center. Mr. Payne Templeton of Sun City will talk about America's concern for education in developing countries. He will mention his experience working on educational foreign aid in Latin America and the Far East.

TOWN HALL SWIM CLUB will meet Thursday, March 7, 10:00 AM in the club room next to the Lounge. Good times in the swim pools are just ahead. Come to the meeting and renew old pool friendships and make new ones. Everybody welcome.

SUN CITY AGRICULTURAL CLUB will meet at 10:00 AM Tuesday, March 5, in the clubroom at the northwest corner of Town Hall Center. Among items on the agenda for discussion are March plantings, a proposed trip to the U of A Agr. Station, the status of the farms, and the purchase by the club of seeds, insecticides, fertilizers, and a wheelbarrow.

FRIENDS OF THE LIBRARY will hold their regular monthly meeting on Monday, March 4, 7:30 PM, in Town Hall Center. Mr. Robert D. Holtz, who for 34 years was an administrator in the Bureau of Indian Affairs, will speak on Problems of Education and Assimilation of American Indians. All residents and visitors, in addition to members, are invited to attend.

LAPIDARY "SHOW AND TELL" - The second annual "Show and Tell" will be presented on Saturday, March 9, on the Town Hall Center patio from 10:00 AM to 4:00 PM. Fifty or more members will display hand-crafted jewelry and other items which they have made in the lapidary hobby shop. Judging from the response of those visiting the show last year, a good crowd is expected. All Sun Citians and the general public are invited. Free refreshments will be served during the show. The committee in charge is made up of Mrs. Don (Ann) Park, Walter Schroeder and Ed Fader.

SUN CITY ORGAN CLUB will meet March 7, 7:30 PM, in the Town Hall Lounge. The guest organist will be Mr. Ehrman S. Reynolds of Sun City. Mr. Reynolds is an experienced church organist as well as an entertainer at hotels and conventions playing dinner music. He studied pipe organ at Wyoming Seminary, Kingston, Pa. Also playing the organ that evening will be Mrs. Fred P. Weberlein and Miss Evelyn Erickson, Club members. Others of our membership will have an opportunity to play, so please come prepared. We are attempting to make this a participation club with enjoyment for all. Sun Citians who are interested in organ music are invited to attend.

SUN CITY WOMEN'S CHORUS will sing on Tuesday afternoon, March 26, 1:30 PM, for the monthly meeting of the United Presbyterian Women's Association. Chorus director is Jo Gerig; accompanist Gertrude Hunt. Chorus rehearsals are held each Wednesday morning at Town Hall Center Auditorium, Room 4.

Hats Off" to the Unpaid Monitors. Their tireless effort helps make Sun City what it is.

BARBER SHOP QUARTET LOVERS

A 60-voice male chorus from the Phoenix, Saguaro Chapter S.P.E.B.S.Q.S.A., Inc., will present a program at Town Hall SOUTH Wednesday, March 27, at 7:45 PM.

TOPICS

DRIVE DEFENSIVELY

Join the SAFE DRIVING CAMPAIGN.

The life you save may be your own.

We suggest that you proceed cautiously at all intersections. In this way, we will not only protect ourselves but also our visitors who are not as familiar with our traffic patterns.

TOWN HALL ART CLUB will meet March 12, 1:00 PM, in the club room. Adrian Hanson, a well known artist in the valley will give a demonstration on the uses and techniques of acrylics. The Club will host a lecture on the "Standards of Judgment" in Art by Mr. Donne Puckle, who is Associate Director of the Phoenix Art Museum, March 18, 7:00 PM, in the Town Hall Auditorium on Peoria Avenue. Anyone interested in art is cordially invited to attend. Paintings by members of Town Hall Art Club will be on display. Registration for the new classes in art instruction will be held as follows:
Hall Abrisch - March 8 - 1:00 to 4:00 PM
Ruth Moore - March 6 - 10:00 to 12:00 N.
Hal Benson - March 8 - 9:30 to 12:00 N.
You must bring your Town Hall membership cards when you register.

PIANO-ORGAN CONCERT Plans have been made for a piano-organ concert at Town Hall South Auditorium on Sunday, March 10, 2:30 PM, with Ray Turner of Harmony House at the organ. Mr. Turner is master of music of all moods and will provide an entertaining concert for music lovers. This will be a benefit performance and your donation will be appreciated. Persons unable to attend but desiring to contribute may do so at the Town Hall office. A committee has been formed to raise funds for a piano and organ. Members of this Committee are: Reg Hauge, Chairman, Ethel Murphey, Kathleen Austin, E.W. Carson, Les Behnke, Ken Osberg and Jim Higginbotham.

In a business executive's office hangs a placard which reads:

"There is no limit to the amount of good a man can do, if he cares not who receives the credit."

This may apply to all of us. If we are truly interested in our community, its growth, its fellowship and well being, we will forget the credit in the joy of a job well done.

We may draw a circle, and shut them out,
By deed, action and word of mouth,
But love and kindness has the power to win,
If we draw a circle and take them in.

TO YOU GOLFERS

The perfectionist pro says:
"Keep your eye on the ball
Your shoulder to the wheel
And your ear to the ground"
Now try to tee off in that position.

TOWN HALL MOVIES FOR MARCH
AT
TOWN HALL SOUTH

MARCH 4 - Matinee 1:00 PM - Evening 7:30 PM
WALT DISNEY FESTIVAL
The Vanishing Prairie
Grand Canyon
Bear Country
The Living Desert

MARCH 11 - Evening 7:30 PM
DODGE CITY
ISLAND ODDITIES (Bahamas)

MARCH 18 - Evening 7:30 PM
LOSS OF INNOCENCE
THE LAND CALLED NEW JERSEY

MARCH 25 - Evening 7:30 PM
SON OF PALE FACE
DISCOVER HAWAII

*****	*****	*****
* TOWN HALL *	* TOWN HALL *	* TOWN HALL *
* NORTH *	* CENTER *	* SOUTH *
* 10725 OAKMONT DR. *	* 10600 PEORIA AVE. *	* 9749 - 107TH AVE. *
*****	*****	*****

This is your first Bulletin after a vacation during June, July, and August for all connected with its publication including the faithful "Town Criers" who have been responsible for its distribution. Our thanks to the "Town Criers" for a job well done. (More about these faithful workers in the future.)

Because of the greatly expanded area due to consolidation and the many new homes delivered in Unit 6, your committee has decided that it will be impossible to continue door-to-door distribution as in the past.

Your Bulletin will be printed as in the past, covering items of special importance, plus special notices from all active clubs. Club notices and information should be sent to the Town Hall Center office as in the past. The deadline will be the 20th of each month.

Copies of your Bulletin, along with Del Webb's NEWS LETTER and ACTIVITY CALENDAR, will be available for pick up at TOWN HALL NORTH, 10725 Oakmont Drive, TOWN HALL CENTER, 10600 W. Peoria Ave., and TOWN HALL SOUTH, 9749 - 107th Avenue. We will attempt to make this pickup as convenient as possible for you and we are sure it will contain valuable information. Both the Sun Citizen and News-Sun inform us they will continue to print the WEEKLY ACTIVITIES CALENDAR, as in the past.

* NOTICE *

* First Quarterly Meeting of the Sun City Community Association *

* Town Hall South, 9749 - 107th Ave. *

* 1:30 PM September 9, 1968 *

All former members of the Sun City Civic Association, and Town Hall Center, automatically became members of the new Sun City Community Association, Inc., as a result of the consolidation May 8, 1968. Your membership card to either Sun City Civic Assn. or Town Hall will admit you. Plan to attend and meet your new officers. This will be the first opportunity to learn of the progress of your new corporation. Mark your calendar now and plan to attend.

This has been in effect for some months now, but since so many have been away, we want to repeat it. If you are an activity card holder, all facilities at any location in Sun City are available for your use.

All pools are open and operating. Rules are being published in the News-Sun and Sun Citizen and will be posted at each pool.

The new shuffleboard courts at Town Hall North will be completed and usable by Sept. 15th.

The Lawn Bowling green at Town Hall North will be closed for several weeks for complete Fall renovation. The other courts will be open as usual.

The grape-vine tells us your Organ Committee came up with a "hot deal" for a new Thomas Organ. They couldn't pass it up. SO-o-o-o-o they bought it. Furthermore, it will be delivered pronto. Keep your donations coming in, folks, since the deal did not include the two external speakers required. The key will be maintained at Town Hall Center and will be presented only to qualified organ players.

SATURDAY NITE DANCE CLUB

Registration for dance instruction classes will be held at 7:00 PM Friday, Sept. 13, at Town Hall Center Auditorium, 10600 Peoria Avenue. Come out and renew old acquaintances.

ROSE AND GARDEN CLUB - will meet Tuesday, Sept. 10, 7:30 PM at Town Hall North Auditorium, 10725 Oakmont Drive. THE CHANGE OF MEETING PLACE IS FOR SEPTEMBER ONLY.

SUN CITY ORGAN CLUB will meet in Room B in the Club Room east of Town Hall Center Lounge, on Friday, Sept. 6, at 7:30 PM. All Sun Citizens who are interested in organ music are invited to attend. Our guest artist will be Mr. Richard Kaysen, Administrator of Sun Valley Lodge.

TOWN HALL LAPIDARY CLUB will start its Fall season with a meeting of its members on Friday, Sept. 6, at 1:30 PM in Club Room #1. All members are urged to attend. Formal instruction of trainees will begin Friday, Sept. 13. All trainees are requested to contact the monitor at the shop so reservation may be made with the instructors.

MOVIES

TOWN HALL SOUTH AUDITORIUM
MONDAY 7:30 PM

- Sept. 16 - "TEN WHO DARED" - Brian Keith, John Beal, David Stollery
"WILD RIVERS" - Adventure film - magnificent photography
- Sept. 23 - "MOVE OVER, DARLING" - Doris Day, James Garner, Polly Bergen,
Chuck Connors, Thelma Ritter, Don Knotts
- Sept. 30 - "KING SOLOMON'S MINES" - Deborah Kerr, Stewart Granger,
Richard Carlson.

LAWN BOWLS CLUB - Summer hours effective through September:

TOWN HALL CENTER GREEN - Tuesday,
Thursday and Saturday.

TOWN HALL SOUTH GREEN - Tuesday,
Wednesday and Friday.

Hours at both locations - 8:00 AM and
7:30 PM.

Instruction classes - Town Hall Center,
Mondays and Wednesdays at 7:30 AM. Begin-
ners class Thursdays at 7:30 AM. Ladies
day every 4th Tuesday. Next business
meeting will be September 9th at 10:00 AM
in the Art Room at Town Hall Center.

SUN CITY WOMAN'S CHORUS will resume weekly
rehearsals on Wednesday, Sept. 4, at 9:30 AM
in Room A-3 at Town Hall Center Auditorium.
Several programs are already planned,
including the annual Christmas Concert
presently scheduled for December 8th at
Town Hall South. Any women interested in
singing three-part music should contact
Jo Gerig, Director, 933-0085; Evelyn Robb,
Chairman, 933-0335; or Ethel Murphey,
933-2672.

SENIOR WOMEN'S LEAGUE - On Sept. 19th at
10:00 AM in Town Hall South, Chairman
Dolores Adams will sound her gavel to open
the 1968-69 meetings of the Senior Women's
League. Mr. Wendell R. Newell, Superintend-
ent of Arizona Boys' Ranch, will speak on
"The Subject is Boys." He speaks with
authority, "know how", and compassion about
his boys. Beth DeCoursey and her pro-
gram committee have planned an exciting
series of meetings for the year. We won't
tell you all that will happen, but just to
make you curious, some key words are
International pageant, decorations, music,
murals, theater, children, books, and travel.
484 members of S.W.L. cordially invite all
Sun City women holding current activity cards
to join with us once a month on the third
Thursday each month in Town Hall South for
FACTS, FUN AND FELLOWSHIP.

SUN CITY AGRICULTURAL CLUB - After a summer
vacation, the club will resume its monthly
meetings Tuesday, September 3rd at 10:00 AM
in the club room at the NW corner of Town
Hall Center. It is hoped that Mr. Childress
will attend this meeting. Possibly
Mr. McClung's committee will have a report.
The county agent recommends the planting
of 19 vegetables in September.

CONTINENTAL DANCE CLUB continues to meet on
the 2nd and 4th Wednesdays of each month
at 8:30 PM, Town Hall South, 9749 107th Ave.

CERAMIC CLUB - Activities for September.
The next business meeting of the Ceramic
Club will be 9:00 AM Sept. 9th at the
Town Hall Center Club room. A good turnout
is expected as there shall be new classes
and new business to be discussed. Both
old and new members are urged to attend so
that the fall program can be a great success.
It is planned to have guest instructors,
classes in stains, glazes, antiquing,
decoupage and free form. New molds will
be added for more interest in casting.
Information is written on blackboard in
club room informing members of weekly
changes in program.

SUN CITY HAND BELL RINGERS will start fall
activities on Sept. 5th when the Thursday
group will report for rehearsal at Town
Hall Center at 9:00 AM. The Friday group
will report at 9:30 AM on Sept. 6th. We
are grateful to Mr. & Mrs. Howard Lentz
for their generosity in providing us with
one more octave of handbells. We now
have 37 handbells and we need additional
ringers. Those interested please call
Mrs. David Gerig, director, 933-0085, or
Mrs. Edward Austin, 933-2578.

Make a tour of Town Hall North, 10725 Oakmont Drive, and see the new pool facilities
and the new building housing sewing, art, and bridge clubs.

Town Hall Center, 10600 Peoria Avenue, has been renovated and redecorated.

Town Hall South, 9749 - 107th Avenue, is more beautiful than ever with the grass and
shrubbery in full color. More changes will come. We believe you will be proud of
YOUR expanded facilities.

VOL. 3, No. 5

May 1, 1969

ATTENTION -- ALL SUN CITY RESIDENTS

The next regular quarterly meeting of the Sun City Community Association Corporation will be held Monday, May 12, 1969, at 1:30 PM at Town Hall South.

Please mark your calendars and plan to attend this very important meeting. You will be rewarded with the personal satisfaction of your participation in Corporation activities.

Douglas V. Lowther
Public Relations Chairman

MEN'S CLUB ACTIVITIES FOR MAY

- 1 - Bingo Parties - May 14 and 28 - 7:00 PM
- 2 - Golf Tournament - May 12 - South Course - best ball foursome.
- 3 - Mother's Day Pancake Breakfast - May 10 - 8:00 to 10:00 AM. Town Hall Center Auditorium. Wives are welcome and there will be no charge.

The Club Rooms are located at Town Hall North and are open from 12 Noon until 5:00 PM - on Saturdays, from 12 Noon until 5:00 PM. Lunch is served on Saturdays.

THE SUN CITY MALE CHORUS

Forty-eight men will present an evening of song on Sunday, May 4th at 8:00 PM in Town Hall South. The songs will include numbers from Fred Waring's and Robert Shaw's Choral Series and several pieces will feature soloists. This will be the final public appearance for the 1968-69 season of this group under the direction of Mark Cassells and with accompanist Esther Weiss. There will be ample seating for a large audience. Those attending will have an opportunity to make a free-will offering which will be used for their music library and necessary equipment for next year's program which will be the start of their seventh year.

ON MOTHER'S DAY
By Robert W. Norris

Could I but write to Mother
In that home so far away
And say how much I think of her
On this dear Mother's day.
Of the lessons that she taught me
As I knelt down by her knee,
The man that in the future years
She hoped that I would be.

The passing years cannot erase,
From out my memory,
The vision of her kindly face,
And all she did for me.
So when I think of all these things,
For which I can't repay,
It reminds me of the debt I owe,
On this dear Mother's Day.

THE FRIENDS OF THE LIBRARY will hold their regular monthly meeting at 1:30 on May 5th at Town Hall Center. Mr. Robt. H. Bucknam will speak on "Inflation or Deflation", Government Policy and the Investor, 1969. Mr. Bucknam has had many years experience in investment counselling.

EDITORIAL

It is said that high above the earth with its clutter of haste and confusion, all celestial movements and sounds blend into a perfect harmony - a symphony of all the spheres.

How foolish then are our petty divisions and differences. We all learned to clothe, shelter, and provide for our many needs. The same sun shone upon us all, and the same Mother Earth will care for us when our days are over.

Verily, life is too short for hate, too hard for greed, too bitter for selfishness and misunderstandings, and too lonely for unkindness. We were born free and equal - we are brothers all.

The month of May is known as moving time in most northern states, while many southern families migrate northward into higher altitudes and cooler areas. And yet, there are those of us who enjoy the climate of the Valley of the Sun. We even enjoy playing hosts to friends, relatives, and those dear grandchildren.

May you all have a most pleasant and enjoyable summer vacation. So - "Aufwiederschen" until September.

SENIOR WOMEN'S LEAGUE

Meeting on May 15th at 10:00 AM in Town Hall South for their annual luncheon and installations of 1969-70 officers. Members of the Phoenix Junior Symphony will present the program. Tickets at \$1.75 are available from Mrs. Ralph Pickering, 933-4202, and Mrs. Harold Nass, 933-0382.

TOWN HALL SWIM CLUB - Regular business meeting at 10:00 AM Thursday, May 1st, on the Patio back of Town Hall Center office. Coffee and rolls will be served to members and their guests.

TO GRANDMAS

While we're honoring our mothers
With songs and words of praise
While we tell about their kindness
And their tender loving ways
We should like to honor grandmas
They are mothers too, tho old
For they mothered our dear mothers
In the fond memories we hold.

A THOUGHT

You have never lived a "perfect day"
even tho' you have earned your wage,
unless you have done something for some-
one who will never be able to repay you.

SUN CITY AGRICULTURAL CLUB will meet May 6th at 10:00 AM, Town Hall Center Auditorium. The proposed rules and regulations will be re-read, discussed, and voted on. It is expected that new gardening plot will be piped and staked by May 1st. If completed, plots will be assigned at meeting.

THE MANAGER REQUESTS:

To cut down on expense of set-ups, it is important for the clubs to notify the office of all changes or cancellations. Phone 933-0127.

Deadline for Town Hall Calendar is the 15th of the preceding month.

SUN CITY ORGAN CLUB - Meeting will be held Wednesday, May 7, 1969, at Town Hall South 7:30 PM. The program will be Piano and Organ duets by the following members: Mrs. Carrie Arlt and Mrs. Lucille Weberlein; Mrs. Blanche Lesser and Mrs. Dorothea Schu- lenberg. The Club is very fortunate to have as many talented members who have enter- tained at the meetings. No doubt there are others just as talented who haven't ventured or offered to play. This is their chance to play the fine organ at Town Hall South before an audience and among friends - hope they will take advantage of it soon. There will also be a discussion regarding the Organ Parties to be held for those who remain in Sun City during the summer.

TOWN HALL LADIES' GYM CLASS--will hold their annual Spring Party starting at 9:00 AM in Town Hall Center Monday, May 12. There will be lots of fun, food, entertainment and re- freshments. Lots of "Double Hitches", "Twinkles", "Grapevines", "Twirls", "Boxes", "Ringing of Bells", "Scissors" and What- Have-You! Some surprises too!

ROSE AND GARDEN CLUB - Due to change in pro- gramming, the Rose & Garden Club in the future will meet on the 2nd Monday of each month in the Auditorium of Town Hall Center. The next meeting will be May 12th at 7:30 PM. Be sure to bring your roses for judging and presentation to the Sun Valley Lodge.

ART CLUB PICNIC - All members are urged to bring their sketch books and lunches for a sketching picnic to be held at Bumble Bee on May 13th. The caravan to Bumble Bee will meet at the Safeway parking lot in Plaza del Sol at 9:30 AM.

SUN CITY ROCKHOUND CLUB - The next meeting will be held on Monday evening, May 12th, at the Club Rooms at Town Hall Center. The guest speaker for the evening will be Michael Sheridan, A.S.U. Geology Dept., who will speak on examining rocks with Polorizing microscopes. Plans will also be finalized at that time for a 3-day field trip May 20, 21, and 22 to the Do-Bell Ranch near Holbrook to look for petrified wood and picture wood. Arrange- ments will be made for those who wish to camp out at the Ranch; otherwise members may spend the night at a motel in Holbrook or other nearby towns. Guests and friends are welcome to attend the meeting and arrange to go on the field trip.

- - - - -

Go often to the house of thy friend,
for weeds soon choke up the unused path.

TOWN HALL MOVIES

NOTE CHANGE IN DAY -
TUESDAY INSTEAD OF MONDAY

TOWN HALL SOUTH AUDITORIUM
TUESDAYS 7:30 PM

NOTE CHANGE IN DAY -
TUESDAY INSTEAD OF MONDAY

- TUESDAY, May 6th - "THE GEISHA BOY" - Starring Jerry Lewis, Marie McDonald, Sessue Hayakawa, Suzanne Pleshette, Barton McLane, and guest stars, The Los Angeles Dodgers.
- TUESDAY, May 13 - "BEND OF THE RIVER" - Starring James Stewart, Rock Hudson, Julie Adams and Arthur Kennedy.
- TUESDAY, May 20 - "OPERATION PETTICOAT" - Starring Cary Grant and Tony Curtis.
- TUESDAY, May 27 - "FLUFFY" - Starring Tony Randall, Shirley Jones, Edward Andrews and Howard Morris.

IMPORTANT NOTICE

ON MEMORIAL DAY, FRIDAY, MAY 30, ALL EVENTS WILL BE CANCELLED AND THE FACILITIES WILL BE CLOSED.

THE SWIMMING POOLS WILL REMAIN OPEN.

- - - - -

TREES

(Not by Joyce Kilmer)

I think that I shall never see
Along the road, an unscraped tree
With bark intact and painted bright
That no car ever hit at night.
For every tree that's near the road
Has caused some auto to be towed.
Sideswiping trees is done a lot
By drivers who are not so hot.
God gave them eyes so they could see,
Yet any fool can hit a tree.

America is a wonderful country -
where else can you walk out of your
mortgaged home, step into a time-payment
car, and drive down a freeway on credit
gas to charge something at your
favorite store.

- - - - -

Doing nothing is the most tiresome job
in the world because you cannot quit
and rest.

YOUR SUN CITY COMMUNITY ASSOCIATION BOARD OF DIRECTORS wishes to remind you of all the following important events of vital interest to all:

The regular QUARTERLY MEETING of the SUN CITY COMMUNITY ASSOCIATION CORPORATION will be on NOVEMBER 10, 1969, at 1:30 PM at Town Hall South. The agenda of this meeting will include report of the Nominating Committee and nomination of candidates for the BOARD OF DIRECTORS for 1970.

A joint election with the Sun City Home Owners Association will be held at Town Hall South on Thursday, December 4, 1969. Exercise your franchise for the continuation of constructive and progressive management of the wonderful facilities provided the membership in this beautiful city.

Support your annual Sun City Arts & Crafts Show to be held at CHRIS-TOWN CENTER November 6 through November 8, 1969. Chairman Mrs. Ida Mae Schwartz and Co-Chairman Mrs. Bertha Cox report the show will be worthwhile and interesting with many clubs participating.

Mailing the Town Hall Bulletin to each residence is beset with many costly problems that will take some time to solve. During this interim period, arrangements have been completed with Safeway Stores to place containers for Bulletin distribution in each store beginning on November 1, 1969 for the convenience of all concerned. Our gratitude to the Safeway Store managers for their wholehearted cooperation. Further study for more distribution locations will continue and progress reports will be made periodically.

The 10th Anniversary of Sun City will be celebrated all the month of January 1970 with many parades, shows, tournaments and the dedication of the new Lakeview Center. A committee composed of representatives of the Del E. Webb Corp., Merchants Ass'n., and Community Ass'n. Directors, are busy formulating plans and schedules of events and when completed will be given adequate and timely publicity for all to attend.

WOMEN'S CHORUS will participate in the "Sun City Day" program at the Arizona State Fair, on the morning of Nov. 6, 1969 10:00 AM to 12:00 Noon, at the Fair Grounds in Phoenix. The program is sponsored by the Del E. Webb Corp., and Jerry Svendsen will act as Master of Ceremonies.

Plans for the annual Christmas program, to be given at Town Hall South on Sunday evening, December 7th, are well under way, and tickets may be purchased now from any member of the Chorus. \$1.00 donation.

AGRICULTURAL CLUB will meet Tuesday, November 4th, in Room B-1, at Town Hall Center, at 10:00 AM.

TOWN HALL SWIM CLUB - regular business meeting will be at 10:00 AM Thursday, November 6, in Room B-1, Town Hall Center clubhouse. Agenda will include appointment of a nominating committee to select candidates for office for the year 1970.

HANDBELL RINGERS are diligently practicing for their participation in "Sun City on Stage" November 6th at the State Fair, and for their joint concert December 7th at Town Hall South with the Male and Women's Choruses. Tickets may be obtained from any Handbell Ringer. Anyone with a musical background wishing to audition for ringing should contact Director Jo (Mrs. Dave) Gerig, 933-0085.

SUN CITY PLAYERS will present "TAKE YOUR MEDICINE", a three-act comedy, where all the action takes place in a room of the Boswell Memorial Hospital and centers around two male bed patients, a sour-puss head nurse, three pretty regular nurses, and a dumb-dora student nurse.

The show will be given as a benefit for the Boswell Memorial Hospital Auxiliary on Tuesday and Wednesday, November 18th and 19th, at Town Hall South. Please buy tickets.

FRIENDS OF THE LIBRARY - At the regular monthly meeting, Dr. John F. Prince, President of the Maricopa County Junior College District, will review "IN THIS HOUSE OF BREDE", the latest novel of Rumer Godden, which has already made the best-seller list and will be available at the Sun City Library. The public is invited to attend this meeting at 1:30 PM November 3rd, in the Center Auditorium.

CONTINENTAL DANCE CLUB has changed the starting time of its dances from 8:30 PM to 8:00 PM. In the future, the dances will be from 8:00 PM till 9:30 PM. The club holds dances each month on the second and fourth Wednesdays at Town Hall South.

ROUND DANCE CLUB - Meeting at Town Hall Center every Monday, will change their set-up. Starting November 3rd, beginners classes will be from 8:30 to 9:30 AM; Intermediate from 9:30 to 11:00 AM, at Town Hall Center.

The GYM CLASS will be a separate class, meeting on Friday, November 7th and every Friday thereafter, from 8:30 to 9:45 AM, at Town Hall South.

Doing nothing is the most tiresome job in the world, because you cannot quit and rest.

MEN'S CLUB - meets each day at Town Hall North 12:00 to 5:00 PM, except Sunday and Holidays. On Saturday, 11:00 AM to 5:00 PM with lunch served beginning at 11:00 AM.

A golf tournament will be held for club members only on Nov. 10th at the North Course. Golfers can sign up at the North or South course not later than Wednesday, Nov. 5th. If you don't have a handicap but would like to play, see Gordon Evans.

A Bingo Party will be held on the 2nd and 4th Wednesdays of the month at Town Hall Center at 7:30 PM Sharp. Any Sun City resident with an activity card, and guests, are welcome.

Tickets are on sale at the club rooms for \$5.00 each, including Bus Fare, to a Ice Hockey Game at the Coliseum between the Phoenix Road Runners and the Vancouver Canucks. Bus will leave the Club Rooms at Town Hall North at 6:30 sharp. Bring the Ladies. We'll have a good time. We will also feed you all the peanuts and popcorn you can eat. The date for this game is Friday, Nov. 14th.

Please keep in mind our big Christmas party to be held on Friday, Dec. 19th, at Town Hall South. Tickets will go on sale at our club rooms on Nov. 1st and the deadline for tickets will be Dec. 10th. Tickets are \$5.00 each. All seats are reserved, so

please get yours early and get the best ones. Dutch treat at the cocktail hour from 6:00 to 7:00 PM. Deluxe dinner served from 7:00 PM to 8:30 PM. A few minutes for club business and then the Stage Show featuring the Sun City Male Chorus, Mr. Mark Cassell, Director; the Sun City Bell Ringers, Mrs. Jo Gerig, Director; the Wesley Methodist Church Choir, all colored cast, singing gospel songs; and two professional entertainers who will be in the Valley at this time to complete our program. Music will be furnished during the cocktail party by the Rhythm Ramblers of Sun City, and during the dinner by Mrs. Blance Lesser at the organ. You are all welcome to come. Every one with an activity card.

Election of officers for 1970 at Club Rooms, Saturday, Nov. 1st, Town Hall North. Polls open from 11:00 AM to 4:00 PM by secret ballot. The candidates are: Leslie Boyd, Alex Makarov, Lowell Elmore, Lloyd Wheadon, Rodney Estey, Amos Whitlock, George Tabor, Earl Corder, John Lagberg, Ernie Shields, Carl Schuetze, Ross Anderson and Clyde Butler.

NOTICE TO ALL CLUBS

Please have your club information for the Bulletin in by the 20th of each month.

PLEASE HAVE INFORMATION FOR THE TOWN HALL CALENDAR IN THE OFFICE ON OR BEFORE THE 15th OF THE PRECEDING MONTH. THE HEAVY SCHEDULE ON ALL FACILITIES REQUIRES MORE TIME IN THE ALLOCATION OF SPACE AND PREPARING THE CALENDAR. SEND TO ATTENTION OF RILL ABRISCH.

OUR FLAGS AT HALF MAST

Henry Ward Beecher said in 1887: "Our flag means all that our fathers meant in the Revolutionary War; It means all that the Declaration of Independence meant; it means all that the Constitution of our people organized for Justice, for Liberty and for Happiness, meant."

TOWN HALL MOVIES
TOWN HALL SOUTH AUDITORIUM
TUESDAYS 7:30 PM

- | | | |
|----------------------|----------------------------------|--|
| TUESDAY - Nov. 4th - | "THE LIVING DESERT" - | An Academy Award winner. Full length true life adventure. |
| TUESDAY - Nov. 11th- | "OKLAHOMA" - | Gordon MacRae, Gloria Grahame, Shirley Jones, Gene Nelson, Eddie Albert, Rod Steiger. |
| TUESDAY - Nov. 18th- | "TAKE YOUR MEDICINE" - | Live - Three-Act Comedy by the SUN CITY PLAYERS, FOR the benefit of the Boswell Memorial Hospital Auxiliary. |
| TUESDAY - Nov. 25th- | "THE TREASURE OF SIERRA MADRE" - | Humphrey Bogart, Tim Holt, Walter Huston, Bruce Bennett. |

Cooperation will solve most of our problems. Freckles would make a nice coat of tan if they could only get together.

ROSE & GARDENCLUB CHRISTMAS PARTY - 5:30 PM
Monday, December 8th, at Town Hall Center Auditorium. Turkey, ham and coffee will be furnished free for this pot-luck. Bring a casserole or dessert and your own table service.

Mr. Wendell Noell will entertain with two squares of Exhibition Square Dancers, with a professional caller, which you will enjoy. Make this evening a Big Fun Christmas Party to wind up the year.

Bring your Roses -- this is the last time to enter Roses for our Little Show. A trophy will be awarded for the highest point winner at the January 12th meeting. We hope to have Mr. Lewis Whitworth, Professional Citrus Consultant, on our program. Last January, his lecture and demonstrations on citrus trees of all kinds was very well received. New residents will enjoy this informative program very much. Everyone welcome.

CONTAGIOUS

Friendliness is contagious. The trouble is, many of us wait to catch it from someone else, when we might better be giving them a chance to catch it from us.

- - -

He has the right to criticize
who has the heart to help.
Abraham Lincoln

- - -

CHRISTMAS CONCERT - There will be a combined musical presentation by the Women's and Male Choruses, and the Handbell Ringers of a "Cavalcade of Christmas Music" on Sunday, December 7th, at 8:00 PM, in Town Hall South. This will feature all three of these groups of 125 voices and musicians offering pleasing selections appropriate for the Holiday Season.

Tickets are available now thru members of all three of the participating groups, or by calling 933-0085, 933-0397, or 933-4666 or at the door the night of the concert for a donation of \$1.00 per ticket.

MEN'S CLUB - meets each day at Town Hall North, 12:00 PM to 5:00 PM, except Sundays and holidays. Lunch served at 11:00 AM to 5:00 PM on Saturday.

December 3rd is the last day to sign up for the Dec. 8th golf tournament. See Gordon Evans for your handicaps. A trophy and prizes will be awarded each flight at our Christmas party. A Bingo party is held the 2nd and 4th Wednesdays at Town Hall Center at 7:30 PM. Any resident of Sun City with a current activity card, and guests, are welcomed. There will not be a Bingo party on December 24th. Remember the Christmas Party on Friday, Dec. 19th, Town Hall South. Get your tickets now - \$5.00 donation. The Rhythm Ramblers, Mrs. Blanche Lesser, organist; the Handbell Ringers; Sun City Male Chorus; Wesley Methodist Church Choir, an all colored singing group; and two professionals, Mr. Jerry Allen, comic Banjo, and Mr. Herbie Sells, comedian, will be our All-Star Christmas Show.

TOWN HALL MOVIES
TOWN HALL SOUTH AUDITORIUM
TUESDAYS 7:30 PM.

- | | | |
|---------------------------|---|--|
| Tuesday - December 2nd - | "A SONG TO REMEMBER" | - Starring Paul Muni, Cornell Wilde, Merle Oberon. |
| Tuesday - December 9th - | "TEN WHO DARED" | - Brian Keith, John Beal, James Drury. |
| Tuesday - December 16th - | "THE MAGNIFICENT REBEL" | - Walt Disney's Dynamic story of Ludwig Von Beethoven. |
| Tuesday - December 23rd - | "RUN, APPALOOSA, RUN"
"ONE DAY AT TETON MARSH" | Walt Disney's action filled story about an Indian girl. |
| Tuesday - December 30th - | "MARY, MARY" | Debbie Reynolds, Michael Rennie, Barry Nelson, Diana McBain. |

NOTICE TO ALL CLUBS

PLEASE HAVE YOUR CLUB INFORMATION FOR THE BULLETIN IN BY THE 20TH OF EACH MONTH.

PLEASE HAVE INFORMATION FOR THE TOWN HALL CALENDAR IN THE OFFICE ON OR BEFORE THE 15TH OF THE PRECEDING MONTH. THE HEAVY SCHEDULE ON ALL FACILITIES REQUIRES MORE TIME IN THE ALLOCATION OF SPACE AND PREPARING THE CALENDAR. SEND TO ATTENTION OF RILL ABRISCH.

PLEASE INFORM THE OFFICE, AS SOON AS POSSIBLE AFTER YOUR ELECTION, THE NAMES, ADDRESSES AND TELEPHONE NUMBERS OF YOUR 1970 OFFICERS.

January 1, 1970

VOL. 4, No. 1

SUN CITY CELEBRATES ITS 10TH ANNIVERSARY - 1960-1970

The calendar of events in January are available at all distribution points. It is hoped that all Sun City residents will participate in the events of their choosing.

SUN CITY CONTINENTAL DANCE CLUB will hold their first dance of 1970 on Wednesday, January 14th. At that time the new officers for 1970 will be inducted.

SUN CITY SPORTSMEN'S CLUB - To our new neighbors who have recently joined us here in Sun City - - A very warm welcome. This is one of the best States in the country for all outdoor activities. If you are interested in anything from bird watching to a big game hunt, do join us every third Monday of the month at 9:30 AM in the B and C clubrooms in Town Hall Center.

The Sun City Sportsmen's Club is affiliated with the Arizona Wildlife Federation and can supply information on where and when to fish and hunt. We can even find partners for you so you won't have to do these activities alone. We also have Archery enthusiasts who will teach, compete, or hunt, with you. We have guest speakers from the Arizona Wildlife Federation show pictures and inform us of all the interesting areas in the State.

Do come and join us January 19th at 9:30 A.M. for a fun-filled morning. Mr. Jack Mantle of the Arizona Fish and Game Commission will show slides and give a commentary of his 3-month African Safari this past summer. Refreshments will be served.

FRIENDS OF THE LIBRARY - Mr. Jack McDonald of the Public Relations Department of the Arizona Public Service Company will address the Friends of the Library at the next meeting Monday, January 5th, at 1:30 PM in the Town Hall Center Auditorium. His subject will be Here's to the Ladies: Women in Books. All Sun City residents are cordially invited.

SUN CITY ROSE & GARDEN CLUB will meet on Monday, January 12th, at 7:30 PM, at Town Hall Center. Activities will include a demonstration of proper rose pruning; presentation of Trophy to the 1969 winner of the Little Rose Show; and installation of new 1970 officers. There will be an outside demonstration of Rose pruning by a Maricopa County Agricultural Agent on Friday, January 16th, at 9:30 AM in the garden of Mr. & Mrs. Herbert Gillis, 9922 Edward Drive. Everyone is welcome.

SUN CITY WOMAN'S CHORUS will resume rehearsals on Wednesday, January 7th at 9:30 AM in the Town Hall Center Auditorium. Chorus officers for 1970 are: Chairman Harriet Bush; Vice-Chairman Ida Argersinger; Secy-Treasurer Gladys W. Queen; Librarian Louise Beemster. Chorus director is Jo Gerig, with Dorothy Giebelstein accompanist.

The Chorus will participate in the 10th Anniversary celebration program on the afternoon of January 17th in the Sun Bowl.

SUN CITY MEN'S CLUB meets in Town Hall North club rooms, 12:00 Noon to 5:00 PM daily except Sundays and holidays. Lunch served at 11:00 AM Saturdays.

Next golf tournament January 12th, North Course. Medal play, full handicap. Sign up for starting time either North or South Course by Wednesday, January 7th.

\$2.00 dues may be mailed in for 1970 membership cards to P. O. Box 519.

January Bingo parties Town Hall Center 7:30 PM Wednesday January 14th and 28th. Community Association activity card holders and house guests invited.

THE NEXT QUARTERLY MEETING OF THE SUN CITY COMMUNITY ASSOCIATION WILL BE HELD AT TOWN HALL SOUTH ON JANUARY 12, 1970 AT 1:30 PM, AT WHICH TIME THE NEWLY ELECTED MEMBERS OF THE BOARD WILL BE PRESENTED. PLEASE MARK YOUR CALENDARS AND PLAN TO ATTEND.

NOTICE ! ALL SUN CITIANS

SUN CITY COMMUNITY ASSOCIATION MEMBERSHIP DUES ARE NOW DUE. THEY MAY BE PAID AT THE TOWN HALL CENTER OFFICE ANY WEEKDAY FROM 9:00 AM TO 5:00 PM

NOTICE TO ALL CLUBS

PLEASE HAVE YOUR CLUB INFORMATION FOR THE BULLETIN IN BY THE 20th OF EACH MONTH.

PLEASE HAVE INFORMATION FOR THE TOWN HALL CALENDAR IN THE OFFICE ON OR BEFORE THE 15TH OF THE PRECEDING MONTH. THE HEAVY SCHEDULE ON ALL FACILITIES REQUIRES MORE TIME IN THE ALLOCATION OF SPACE AND PREPARING THE CALENDAR. SEND TO ATTENTION OF RILL ABRISCH.

PLEASE INFORM THE OFFICE, AS SOON AS POSSIBLE AFTER YOUR ELECTION, THE NAMES, ADDRESSES AND TELEPHONE NUMBERS OF YOUR 1970 OFFICERS FOR THE CLUB ROSTER.

* * * * *

DON'T FORGET TO ATTEND THE QUARTERLY MEETING OF THE SUN CITY COMMUNITY ASSOCIATION - 1:30 PM JANUARY 12, 1970 - TOWN HALL SOUTH AUDITORIUM - TO MEET YOUR NEW OFFICERS AND BOARD MEMBERS.

TOWN HALL MOVIES

Town Hall South Auditorium
Tuesdays 7:30 PM.

- Tuesday, January 6th - "I'D RATHER BE RICH" - Starring Robert Goulet, Andy Williams,
Sandra Dee, Maurice Chevalier.
- Tuesday, January 13th - "INTERLUDE" - Starring June Allyson, Rossano Brazzi.
- Tuesday, January 20th - "A VERY SPECIAL FAVOR" - Rock Hudson, Charles Boyer, Leslie Caron.
- Tuesday, January 27th - "TAMMY & THE BACHELOR" - Debbie Reynolds, Leslie Nielsen.

SUN CITY COMMUNITY ASSOCIATION

BULLETIN

VOL. 4, No. 2

February 1, 1970

THE DEL E. WEBB TENTH ANNIVERSARY CELEBRATION WAS A TREMENDOUS SUCCESS, THANKS TO THEIR OWN EFFORTS AND TO ALL THE WONDERFUL PEOPLE HERE IN SUN CITY, WHO HELPED MAKE IT SO.

The officers of the SUN CITY COMMUNITY ASSOCIATION for the year 1970 are:-

Paul W. Waltz, President; Douglas V. Lowther, Vice-President; Audrey N. Bock, Secretary; Kenneth A. Pearce, Treasurer; John W. Prather, Budget-Finance; Carl H. Anderson, Properties; George A. Shuck, Club Organization; Kenneth O. Marion, Committee on Committees; Gordon Evans, Public Relations-Publicity; and Jay S. M. Titus, Manager.

The various committee members will be announced next month.

SUN CITY SPORTSMEN'S CLUB - Were you at the last meeting? We had a splendid turnout. From all reports, they liked what they saw and heard, as many became new members. This automatically made their wives Associate Members. Dues are \$5.00 per year, which includes affiliation with Arizona Wildlife Federation and the National Wildlife Federation. You also receive the state newspaper published monthly. Mr. Jack Mantle, member of the Arizona Game & Fish Commission showed slides of his 1969 African Safari, and his lively comments on his experiences were enlightening and entertaining. How about joining us at our next meeting to hear Bill Younkers' stories and slides on Alaska. Some of his bear hunting stories will raise the hair on your head (if you have any.) Come and visit with us and see if you would like to join the Club. Ladies! If the old man wants to act like one, leave him home - come down and join our group. (He'll follow) There's something for everyone from Big Game Hunting to Bird Watching. Town Hall Center, Room B, February 16, 9:30 AM. Refreshments will be served.

SUN CITY CONTINENTAL DANCE CLUB - will have LIVE music at their dance on February 11th, starting at 8:00 PM. At that time, and also at the Feb. 28th Dance, 1970 dues of \$2.00 per couple will be collected. Please have your 1970 Sun City Community Association Activity Card with you. We meet the 2nd and 4th Wednesday from 8:00 to 9:30 PM at Town Hall South.

ROSE & GARDEN CLUB - Talk and demonstrations on Citrus growing by Mr. Louis Whitworth, Professional Citrus Consultant and a member of the Board of the Arizona Citrus Growers Association. Time and Date - 7:30 PM February 9th, Town Hall Center.

STITCH & KNIT - All those interested in such a club at Lakeview Center, please meet in the sewing room at Lakeview Center, Wednesday, February 4th, 1:30 PM.

FRIENDS OF THE LIBRARY - Miss Dorothy Weber will present the program for the meeting at 1:30 PM February 2nd in Town Hall Center auditorium. Miss Weber, formerly Assistant Librarian at the Central Public Library in Chicago, has been a volunteer worker in the Sun City library since 1965, and head librarian since Mrs. Mildner's resignation last year. She will talk on current books, many of which have been recently added to the library. She will also bring an exhibit of books purchased from the generous contributions of the Rotary Club over the past years. All meetings are open to the public. For information, please phone Mrs. Mildred Britton, 933-4985.

* DON'T BE A LITTER BUG - *
* EVERY LITTER BIT HURTS; *
* Let us Keep Sun City Homes, *
* Streets and all Facilities *
* CLEAN *

SUN CITY MEN'S CLUB - Meets in Town Hall North club rooms, 12:00 Noon to 5:00 PM daily except Sundays and Holidays. Lunch served at 11:00 AM Saturdays. Next golf tournament February 9th, South Course. Best nine, full handicap. Sign up for starting time, either North or South Course by Wednesday, Feb. 4th. If 1970 dues have not yet been paid, \$2.00 may be mailed to P. O. Box 519. February Bingo parties, Town Hall Center, 7:30 PM, Wednesday, Feb. 11th and 25th. Admittance limited to Community Association Activity Card holders and house guests.

* ARE YOUR 1970 DUES PAID? If *
* not, the Town Hall Center office *
* is open daily Monday thru Friday *
* for your convenience - 9:00 AM *
* to 5:00 PM. Is there anyplace *
* in the whole wide world that you *
* can get as many recreational *
* facilities for \$20.00 per person *
* as here in Sun City? *

- STOP WORRYING -
YOU WILL NEVER GET OUT OF THIS WORLD
ALIVE !

NOTICE TO ALL CLUBS

2/24 - 1/200
SR GEORGE

PLEASE HAVE YOUR CLUB INFORMATION FOR THE BULLETIN IN BY THE 20TH OF EACH MONTH.

PLEASE HAVE INFORMATION FOR THE TOWN HALL CALENDAR IN THE OFFICE ON OR BEFORE THE 15TH DAY OF THE PRECEDING MONTH. THE HEAVY SCHEDULE ON ALL FACILITIES REQUIRES MORE TIME IN THE ALLOCATION OF SPACE AND PREPARATION OF THE CALENDAR. PLEASE SEND TO ATTENTION OF RILL ABRISCH.

MOVIES MOVIES MOVIES MOVIES MOVIES

TOWN HALL SOUTH AUDITORIUM - TUESDAYS - 7:30 PM

- February 3rd - "THE LIVING DESERT" - A triumphantly beautiful search into the true meaning of the great American desert.
- February 10th - "GYPSY" - Starring Rosalind Russell, Natalie Wood, Karl Malden, Paul Wallace, Betty Bruce. Based on the Broadway hit by Arthur Laurents and the memoirs of Gypsy Rose Lee. 14 great songs and in Technicolor.
- February 17th - "THE GREAT RACE" - Starring Jack Lemmon, Tony Curtis, Natalie Wood, Peter Falk, and other great stars. An automobile race from New York to Paris gets under way with two rivals vying for the affections of a pretty reporter (Natalie Wood).
- February 24th - "THE TROUBLE WITH ANGELS" - Starring Rosalind Russell, Hayley Mills, Binnie Barnes, Gypsy Rose Lee, June Harding, and others. These two new students at St. Francis Academy are happy hellions in constant conflict with Mother Superior.

 * ON THE LIGHTER SIDE ! *
 *
 * A fellow said: "I think I'll run *
 * for Congress." His friend replied: *
 * "I wouldn't vote for you if you were *
 * St. Peter." The first man responded: *
 * "If I were St. Peter, you couldn't *
 * vote for me because you wouldn't be *
 * in my district." *
 * *

BILLIARDS SCHEDULE ANNOUNCED !

Because of the interest shown in billiards by the ladies, the entire day of Wednesday has been reserved for the fair sex ONLY at the new Lakeview Center. The Billiard Room will be open from 9:00 AM to 5:00 PM. Men will be permitted to instruct the ladies or observe their progress as they participate.

On Friday, the Billiard Room is reserved the same hours for MEN ONLY, with the ladies permitted to observe the various billiard techniques.

On Monday, Tuesday, Thursday and Saturday, the billiard room is open to BOTH men and women from 9:00 AM to 5:00 PM.

ALL CENTERS ARE OPEN TO SUN CITY COMMUNITY ASSOCIATION MEMBERS !

Due to a misunderstanding by many Sun City residents, the following announcement is made covering all facilities at the three Town Hall Centers, as well as the new Lakeview Center:

THESE FACILITIES ARE AVAILABLE TO ALL SUN CITY RESIDENTS WHO ARE MEMBERS OF THE SUN CITY COMMUNITY ASSOCIATION, REGARDLESS OF WHERE THEY LIVE IN SUN CITY.



Sun City Community Association

BULLETIN



VOL. 4, No. 3

March 1, 1970

GREETINGS TO ALL OF OUR NEW MEMBERS AND OLD. WE HOPE YOU WILL FIND OUR BULLETIN INTERESTING AND INFORMATIVE.

RHYTHM & GYM CLUB of Town Hall Center will have its annual spring party on March 30, at 9:00 AM, at Town Hall Center. A variety of entertainment will be provided by members of the club. Refreshments will be served.

SUN CITY ROSE & GARDEN CLUB

Dr. Elizabeth Rearick and Miss Cari Spencer, Sun Citians, will present a slide show entitled "High Country Odyssey" consisting of mountain scenes and wildflowers at the March 9th meeting, 7:30 PM, Town Hall Center auditorium. On March 18, the club will sponsor a desert-card party from 1:00 PM to 3:30 PM at Town Hall Center auditorium. You can play the game of your choice and players are urged to bring their own cards. Proceeds will go toward payment of expenses of the annual Rose Show to be held October 24 and 25. Tickets may be had by calling Miss Edna Volkman, 933-2367, or tickets may be purchased at the door.

FRIENDS OF THE LIBRARY

Mr. Richard B. Goldberg will review Nicholas and Alexander, by Robert K. Massie, at the next regular meeting, Town Hall Center auditorium, Monday, March 2, at 1:30 PM. Mr. Goldberg has been a member of the Phoenix College Social Science Dept. since 1964, specializing in English history, and has taught English history on television.

SUN CITY SPORTSMEN'S CLUB

Another excellent meeting was had on Feb. 16. During the business part of the meeting, information was passed on to the membership about the Javelina Hunt coming up. Of the 120 people attending the meeting, 18 were women who discovered how interesting the Sportsmen's Club meetings can be. At the March 16th meeting, the guest speaker will be Dr. Paul H. Jarrett, who will give a timely dissertation on "snake bite" and what to do about it. There will be NO snakes at the meeting but Dr. Jarrett will show slides of snake bite and how to treat it. Anyone planning a trip through the desert or forest this spring or summer would do well to attend for this information.

ATTENTION LAKEVIEW MALE RESIDENTS

Are you tired of loafing? Would you like to meet new people and make new friends each week? Are you interested in keeping occupied from 20 to 25 hours a week, with pay?

Then get an application from the Lakeview office for a position as monitor at the swim or therapy pools in the new Lakeview recreation complex. Do it today while openings are still available.

ATTENTION LAWN BOWLERS

Plans for the Arizona State Lawn Bowlers championship are completed. Play begins March 2nd and continues thru March 14th. Play will be at the Town Hall South green on Monday, Wednesday and Friday at 10:00 AM and 1:30 PM. Then on Tuesday, Thursday and Saturday, play will be at the same time at the Lakeview Center green. Spectators are welcome, but are requested not to occupy more than two seats on any bench of the playing end.

SUNSHINE SERVICE, INC., OF SUN CITY - will celebrate its 9th Anniversary on March 14th. All members are invited to attend open house at the Sunshine Service Bldg., 10307 Coggins Drive, in Sun City, on Saturday, March 14, between 10:00 AM and 4:00 PM. Our organization has come a long way since its modest beginning and sincere thanks is extended to all Sun Citians for the help they have given over the years. See you on March 14!

WOMAN'S LEAGUE - The Men's Chorus and the Handbell Ringers of Sun City will present a program for the Woman's League at 10:00 AM March 19th, in Town Hall South. New officers for 1970-71 will be elected during the business meeting. Mrs. MacLeod Coan and Mrs. J. Warner are in charge of hostesses.

SUN CITY MEN'S CLUB meeting in Town Hall North club rooms 12:00 Noon to 5:00 PM daily except Sundays & Holidays. Lunch served at 11:00 AM Saturdays. Next golf tournament, Monday, March 9, north course. Medal Play - Full Handicap. Sign up for starting time, either North or South course by Wednesday, March 4th. March Bingo Parties, Town Hall Center, 7:30 PM Wednesday, March 11th and 25th. Community Association activity card holders and house guests are cordially invited. Bus trips to outstanding big league baseball games will be planned if sufficient interest is shown. These trips last year were a lot of fun. Get your name on the list NOW by phoning 933-9974. You will then be contacted later with complete information as to dates, cost, etc. The ladies are most welcome, naturally.

SUN CITY WEAVERS GUILD - meets each Monday at 10:00 AM, in Craft Room, Lakeview Center. March 2 - Reading of By-Laws -- Weaving. March 9 - Vote on Constitution and Officers - Weaving. March 16, 23, and 30 -- Weaving. Anyone with weaving equipment or weaving books to donate, loan or sell - please let the Weaving Guild know.

MOVIESMOVIESMOVIESMOVIESMOVIESTOWN HALL SOUTH AUDITORIUM - TUESDAYS - 7:30 PM

- March 3rd - "THE MATING GAME" - Starring Debbie Reynolds, Tony Randall, Paul Douglas. A light-hearted spoof about a farmer who operates on a barter economy and has never paid taxes.
- March 10th - "BYE BYE BIRDIE" - Janet Leigh, Dick Van Dyke, Ed Sullivan, John Daly. The freshest, funniest, fastest film musical in years. A zestful show which pokes gentle fun at the younger generation.
- March 24th - "OCEAN'S 11" - Frank Sinatra, Dean Martin, Sammy Davis, Jr., Peter Lawford, Joey Bishop, and others. Guest stars Red Skelton and George Raft. An assorted group of men are called together for a hold-up of five Las Vegas gambling casinos on New Year's Eve.

SUN CITY WOMAN'S CHORUS - will present a musical program at the meeting of the P.E.O. to be held on Monday, March 16th, at 9:30 AM in Town Hall North. Jo Gerig is chorus director, and Dorothy Giebelstein accompanist.

SUN CITY ORGAN CLUB - will meet Wednesday, March 4th, at 7:30 PM, at Town Hall South. Guest organist will be Frank Grenger, Baldwin Organ Distributor of Phoenix. Mrs. Richard Shreve and Mrs. E. Schilling will also give a program of organ music.

SUN CITY COMMUNITY ASSOCIATION - OFFICERS AND COMMITTEE MEMBERS FOR 1970:

Paul W. Waltz, President; Douglas V. Lowther, Vice-President; Audrey N. Bock, Secretary; Kenneth A. Pearce, Treasurer; John W. Prather, Budget-Finance; Carl H. Anderson, Properties; George A. Shuck, Club Organization; Kenneth O. Marion, Committee on Committees; Gordon Evans, Public Relations-Publicity; and Jay S. M. Titus, Manager.

PROPERTIES COMMITTEE

Carl H. Anderson, Chairman	933-6531
Geo. C. Wilson, Vice-Chairman	5023
Wm. J. McDonnal, Member	3672
Kenneth O. Marion "	7539
Walter F. Schott "	5777
Frank C. Joseph "	4249
Daniel Cherry "	7375
Jack H. Newsom "	5648
Al Thomas-Moore "	6865
Harmon Kopperud "	4415
Edward Frey "	7546
Vernon H. Peterson "	3381
Phillip M. Snyder "	5949
Thomas F. Forrest "	4069
Otis Brown "	4451
Edwin L. Forest "	0460
A. LaMonte Loucks Alt. Member	1976
John Hellweg " "	0226
Lowell Petersen " "	4875

BUDGET-FINANCE

John W. Prather, Chairman	933-4485
Kenneth A. Pearce, Co-Chairman	4518
George Carter	5190
Byron Duncan	0506
William R. Loffer	6751

COMMITTEE ON COMMITTEES

Ken Marion, Chairman	933-7539
Geo. A. Shuck, Vice-Chairman	8404
Mrs. Bertha M. Cox	2660
Mrs. Audrey N. Bock	2145
Douglas V. Lowther	7752
Paul Albert	1698

TREASURER

Kenneth A. Pearce	933-4518
John W. Prather, Ass't. Treasurer	4485

PUBLICITY-PUBLIC RELATIONS

Gordon Evans, Chairman	933-4593
Lloyd Wheadon	4277
Edward H. Roos	2410

CLUB ORGANIZATION

George A. Shuck, Chairman	933-8404
Prime Bartley, Vice-Chairman	2696
Mrs. Ida Mae Schwartz	0919
George Eiker	0344
Mrs. Walter Aebischer	2979
Grant Conner	5630
Leo Yort	3512
Elbert Bushnell	7433

"GOOD HEAVENS," SAID THE SWEET YOUNG GIRL, "70 ISN'T OLD FOR A MILLIONAIRE !"

A LOT OF DESIRES ARE NIPPED IN THE BUDGET.



Sun City Community Association

BULLETIN



VOL. 4, No. 4

April 1, 1970

FRIENDS OF THE LIBRARY - In celebration of LIBRARY WEEK in April, we will have open house on Monday, April 6th, at 1:30 PM, Town Hall Center Auditorium. Mrs. Elaine Rice, English instructor at Phoenix College, will review the book "Mr. Sammler's Planet" by Saul Bellow. Miss Dorothy Weber, Sun City Librarian, will display books recently acquired by the library. Following the program, refreshments will be served and guests are invited to browse in the library.

WOMEN'S LEAGUE - The Rev. Dr. Culver Nelson will present a book review at the April 16th meeting, Town Hall South, at 10:00 AM. Mrs. Berlin Henderson and Mrs. Hubert James will be in charge.

SUN CITY SPORTSMEN'S CLUB - At the March 16th meeting of the Sun City Sportsmen's Club, 125 members and guests heard a lecture and saw slides on what to do and what not to do for snake bite. The guest speaker was Dr. Paul B. Jarrett, a Phoenix physician and surgeon, who has made an extensive study of snake bite. This was a timely lecture because the snake season starts in April, peaks in July, and tapers off in September.

The next meeting of the Sportsmen's Club will be Monday, April 20th, 9:30 AM, at Town Hall Center, Clubroom B. The guest speaker will be Bob Hirsch of KTAR-TV Channel 12. Mr. Hirsch is Editor of the Arizona Sportsmen's News Magazine. His talk will be on fishing in Arizona. Everyone is invited to attend.

A picnic will be sponsored by the Sun City Sportsmen's Club April 10th at a beautiful site on the West side of Lake Pleasant. Take the Dirty Shirt turnoff and follow the signs put up by the club to lead you to the picnic site. This is a brand new place so those wishing to attend should bring their own chairs, card tables, food and drinks. There will be boats for rides and fishing from the boats or bank. Bring your friends and neighbors.

A clean-up campaign will be sponsored by the Sportsmen's Club in April - the tentative date is April 23rd.

Come join us at the picnic April 10th and attend our meeting April 20th. Everyone is welcome.

SUN CITY WOMEN'S CHORUS-HAND BELL RINGERS - will present a spring Concert, Town Hall South, Sunday evening, April 12, at 8:00 PM. No tickets will be sold but a contribution of 1.00 per person will be received at the door. Part of the proceeds will help furnish the chapel of Boswell Memorial Hospital. Bob Gerig is Director for both, and Dorothy Heibelstein is accompanist for the chorus. On APRIL 1st, the Chorus will have a luncheon at SIR GEORGE'S BUFFET at 11:30 AM, followed by cards at Town Hall Center. The Women's Chorus has been invited to sing at the State convention of National Federation of Music Clubs April 25th at Travelodge in Phoenix.

SUN CITY ROSE & GARDEN CLUB - The April 13 meeting of the Sun City Rose & Garden Club will be held at 7:30 PM in Social Hall #3, Lakeview Center. Mr. Lowell True, Maricopa County Agricultural Agent, will give an illustrated lecture on the care of lawns, gardens and flowers in Sun City. Residents of Phase II are invited to attend this meeting to hear Mr. True and become acquainted with the purpose of the Club and the members. Every one be sure to bring your roses for our monthly specimen Rose Show.

SUN CITY ORGAN CLUB - will meet Wednesday, April 15th at 7:30 PM, at Town Hall South. Mrs. Robert Cory, Mrs. Clifford Finley, Miss Mary Jordan, Mrs. Leslie Myers, Mrs. Melvin Shikes and Carl Williams will give the program. Refreshments will be served.

TRAVEL TRAILER CLUB IMPORTANT NOTICE TO MEMBERS

Please be advised that the "COMPOUND AREA" is to be moved to a new location - west of the Sunland Memorial Park. It is anticipated that the move will be in the next 90 days. All users of the facility will be advised in ample time to move their equipment, and it shall be the responsibility of the equipment owners to either personally perform the move or make advance arrangements for others to move their equipment. The Club will not assume the responsibility of moving your equipment. Those who will be away from Sun City during and after the final move, shall contact the compound manager upon return to learn their new space number. ANY EQUIPMENT LEFT IN THE OLD COMPOUND AREA AFTER THE FINAL DATE OF OCCUPANCY SHALL BE DISPOSED OF AS JUNK. As the move progresses, details and schedules will be made available to all.

SUN CITY MEN'S CLUB - meeting in Town Hall North Club Rooms 12 Noon to 5:00 PM daily except Sundays and Holidays. Lunch served at 11:00 AM Saturdays. Next golf tournament Monday, April 13, South Course - best ball two-some; full handicap. Sign up at either North or South course. Sign up early as available times are taken quickly. April BINGO parties, Town Hall Center, 7:30 PM April 8th and 22nd. Community Association Card Holders and their house guests are cordially invited. The Men's Club is the most popular of all chartered clubs in Sun City. If you are a male resident and have a 1970 Activity Card, it costs only \$2.00 per year to belong. In addition to our monthly golf tournaments, you may enjoy the good fellowship of other members who meet daily. Also, an annual event, in itself worth more than the yearly dues, is the MOTHER'S DAY PANCAKE BREAKFAST. This year it will be on Saturday, May 9th, in

- over -

MEN'S CLUB (continued)

WANT TO LOSE WEIGHT?

Town Hall Center Auditorium. All Men's Club members and their wives are served a complete breakfast - fruit juice, pancakes, bacon, coffee, etc., as guests of the club. Men, if you are not already a member, you should immediately investigate the benefits of becoming one.

Sun Citians who are overweight will be glad to know that a new Weight Watchers Club has been formed. It is for both men and women and meets each Tuesday evening at 7:30 PM in the exercise room of Town Hall South. Come and find out about the diet that really works.

THE SUN CITY PLAYERS are presenting a delightful 2-Act Comedy, "SUSAN SLEPT HERE", at Town Hall South on Monday, April 6th and Tuesday, April 7th. The action takes place in Pacific Palisades, Los Angeles, when a Hollywood writer, bachelor Joe Norton, played by J. George Bender, through no act on his part, is presented with a Christmas present in the person of a 17 year old delinquent, Susan Landis, played by Lois Moulton. Ralph Gump, as Sergeant Hanlon, and Don Stewart, as Sergeant Maizel, are detectives who decide that Joe needs Susan for research material. Ken O'Blenes, as Virgil, Joe's commanding officer; Gertrude Pryor as Georgette, Joe's maid; Helen Hilden as Maud, Joe's secretary; and Judith Ann Trevillion as Isabella, Joe's Girl.

MOVIES

MOVIES

MOVIES

MOVIES

MOVIES

TOWN HALL SOUTH AUDITORIUM - TUESDAYS - 7:30 PM

APRIL 14th - "A STORM CALLED MARIA"
and "VANISHING PRAIRIE"

- "A Storm called Maria" based on the best seller "STORM", by George Stewart. This unique pictorial biography of one titanic hurricane becomes a drama as suspenseful as any fictional thriller. "Vanishing Prairie" relates the story of THE GREAT AMERICAN PRAIRIE, the vanishing wildlife of the American scene, bringing intimate stories of birds and animals now almost extinct.

APRIL 21st - "BRIGHTY OF THE GRAND
CANYON"

- Starring Joseph Cotten, Pat Conway, Dick Foran, Dandy Curran, Karl Swensen, as Theodore Roosevelt and "Brighty", the donkey. "Brighty" is the wonderful story of the shaggy little burro with a natural instinct for discerning good and bad in human beings, a mountain lion hunter, an old prospector, and a boy, all of whom lived in and around the Grand Canyon.

APRIL 28th - "MOVE OVER, DARLING"

- Starring Doris Day, James Garner, Polly Bergen, Chuck Connors, Thelma Ritter and Don Knotts. A Remake of a hilarious comedy of the late 1930's - My Favorite Wife - retains all the fun of the original.

* * * * *

* * * * *

What this world really needs is a computer that can figure out all the things in life that don't add up.

"I understand you're a TV producer," said the lady. "What shows are you to blame for?"



Sun City Community Association

BULLETIN



Vol. 4, No. 5

May 1, 1970

HEAR YE, HEAR YE, ATTENTION ALL SUN CITY RESIDENTS

The next regular quarterly meeting of the Sun City Community Association Corporation will be held MONDAY, MAY 11, 1970, at 1:30 PM, AT TOWN HALL SOUTH.

Please be sure to mark your calendars and plan to attend this very important meeting. There will be a very comprehensive report given by Mr. Paul Waltz, your president, and all of the members of the board. Mr. Jay Titus, your very able manager, will give his report for the past quarter.

There will be a question and answer period. This is the time for all Sun Citizens to find out about the activities that are taking place within the Association.

The Board of Directors welcome and urge each of you to attend so that you may be heard from. We will welcome any constructive ideas to make your Association a better one. SO, PLEASE DO COME.

I would ask the Chairmen of all the Sun City clubs to remind their members of this meeting and to urge them to attend.

Gordon Evans, Chairman
Public Relations

SUN CITY SPORTSMEN'S CLUB

At the April 20th meeting of the Sun City Sportsmen's Club, members and guests heard Bob Hirsch of Channel 12, KTAR-TV, tell about the best places to fish in Arizona. Newcomers to Arizona were amazed at the information of the many lakes and streams to be fished. Bob Hirsch is editor of the magazine, Arizona Wildlife Sportsman, and is happy to share his knowledge of fishing in Arizona with everyone.

The next meeting of the Sportsmen's Club will be Monday, May 18, 9:30 AM, Town Hall Center, Clubroom B. The guest speaker will be James Sparks, manager of the White Mountain Recreation Enterprise. He will lecture on the Apache Indian Reservation at White River, Ariz., and show films on Indian activities. Everyone is invited to come and learn about the recreational features of the Apache Indian Reservation - home sites and Hawley Lake trailer sites. For fishermen, there will be literature on fishing near Show Low and Pinetop; for hunters there will be brochures on Elk, Antelope, Bear and Lion. This should be one of the outstanding lectures of the year. You are in Indian Country - so shouldn't you learn something about your new environment?

Mark your calendar for May 18th and join us for fun and information. Bring your friends, and that includes your lady.

FASHION SHOW - Mark your calendar - Wednesday May 6th, 10:00 AM. This is the date for the Fashion Show sponsored by the Stitch & Knit Club and the Sew 'N Sew Club, to be held around the pool at LAKEVIEW CENTER. Dresses, suits, swim suits, play clothes and accessories made by Sun City Ladies will be modeled. Music by the Rhythm Ramblers. Don't forget the date. MEN ARE WELCOME.

LAKEVIEW CLAY CLUB

Activities have been going strong at our Clay Club, with classes in decorating greenware, casting, and freeform work. Anyone interested in wheel work would enjoy the wheel provided. This wheel is the very latest in this type of equipment.

The next business meeting will be on May 7th at 1:00 PM. This will be the last meeting until Sept. 3rd. There will be no program in May but the business meeting will be followed by a general Ceramic workshop for those interested, and also for the freeform group.

Mark May 7th on your calendar and bring your work. Happy Ceramic-ing.

ORGAN CLUB

The Organ Club will meet May 6th at 7:30PM at Town Hall South. This will be the last meeting until September. The program will be given by Mrs. Stephen Fulmer and Mr. Lee A. Donnell. Mrs. Fulmer will give a musical travelog. Mr. Lee A. Donnell, of Gavetts Piano & Organ Salon of Phoenix, will play on E-3 Model Yamaha Organ.

There will be a social hour after the program. Please come.

FRIENDS OF THE LIBRARY - Will present Mr. M. Peter Overson, head of the Theater Arts Dept., Glendale College, as the speaker at their last regular meeting of the season, Monday, May 4th, 1:30 PM, Town Hall Center Auditorium. His topic will be "The Trend of the Theater and of the Musical Theater Today". Mr. Overson directs plays at G.C.C. and is house manager at Palace West. He spent four years in New York studying, acting, and directing. All are welcome.

HOW ABOUT A PAT ON THE BACK FOR MR. JACK JACKLEY AND HIS STAFF * * * * *

Since April 1st, the four SCCA swim pools have been in full operation seven days a week on a 10:00 AM to 6:00 PM schedule. The three therapy pools are open 10:00 AM to 6:00 PM Monday thru Friday; 10:00 AM to 5:00 PM on Saturdays; closed on Sundays. Jay Titus, SCCA Manager, is gratified by the periodic inspection reports from Maricopa County Health Dept. officials on the excellent condition of all SCCA pools and shower rooms. Says Titus, "There are no pools in the entire county that excell our own in cleanliness and inpurity of water, and this includes those at the luxury resort hotels." Full credit must be given to our pools supervisor, Jack Jackley, and his staff of dedicated monitors who start the day at 6:00 AM in order to be ready for the 10 o'clock opening.

Total attendance at all pools is now running over 500 per day and is expected to increase to well over 1,000 during the summer months. This makes the pools by far the most used facility in Sun City. We appreciate your fine work, fellows.

ON MOTHER'S DAY

By Robert W. Norris

Could I but write to Mother
In that home so far away
And say how much I think of her
On this dear Mother's day.
Of the lessons that she taught me
As I knelt down by her knee,
The man that in the future years
She hoped that I would be.

The passing years cannot erase,
From out my memory,
The vision of her kindly face,
And all she did for me.
So when I think of all these things,
For which I can't repay,
It reminds me of the debt I owe,
On this dear Mother's Day.

TO GRANDMAS

While we're honoring our mothers
With songs and words of praise
While we tell about their kindness
And their tender loving ways
We should like to honor grandmas
They are mothers too, tho old
For they mothered our dear mothers
In the fond memories we hold.

PARODY ON THE STAR SPANGLED BANNER

Oh, say can you see by the dawn's early light
How we sit by de creek for dem fishes to bite,
We is non working poor folks wid nary a care
Cause de goberment send us dat lovely welfare
Dey mails us de momey we don't give back
Dat's why we can drive our new Cadillac
And don't have to work, cause rich folks pay.
Po rich folks must labor from sun to sun
To pay welfare taxes while we has de fun
We don't pay no taxes, we don't rake no goods
Just raise mo' little kids way back in the woods.
Dey pay us to vote and reward us for sin
While dem sweet demmycratics keep de checks comin in.

SUN CITY ROSE & GARDEN CLUB

Will hold a pot luck supper and dance on Monday, May 11th, at 6:00 PM at Town Hall Center Auditorium. Every one is invited to attend with guests and friends. Ladies are to bring a hot dish, salad, or dessert, and the men will bring a one dollar donation. Anyone expecting to attend, please phone Miss Edna Volkman, 955-2367, and advise her what you will bring. Coffee will be furnished by the Club.

Proceeds will be used towards the expenses of the annual Rose Show which will be held October 24th and 25th. In the past the local Rose Show has been the largest and most outstanding in Arizona.

HELP KEEP SUN CITY BEAUTIFUL.

SUN CITY MEN'S CLUB - meeting in Town Hall North Club Rooms, 12:00 Noon to 5:00 PM daily except Sundays and Holidays. Lunch served at 11:00 AM Saturdays. Next golf tournament Monday, May 11th, North Course - Medal Play, full handicap. Sign up at either North or South Course. Sign up early as available times are taken quickly. May BINGO parties, Town Hall Center, 7:30 PM 13th and 27th. Community Association card holders and their house guests are cordially invited.

The Men's Club is the most popular of all chartered clubs in Sun City. If you are a male resident and have a 1970 Activity Card, it costs only \$2.00 per year to belong. In addition to our monthly golf tournaments, you may enjoy the good fellowship of other members who meet daily. Also, an annual event, in itself worth more than the yearly dues, is the MOTHER'S DAY PANCAKE BREAKFAST. This year it will be on Saturday, May 9th, in Town Hall Center Auditorium. All Men's Club members and their wives are served a complete breakfast - fruit juice, pancakes, bacon, coffee, etc., as guests of the club. Men, if you are not already a member, you should immediately investigate the benefits of becoming one.

* * * * *

LAST BULLETIN UNTIL SEPTEMBER

* * * * *

We take this opportunity to wish each and everyone of you a most pleasant summer, whether it be spent here at home on the desert or in the cool, cool, north country. Best of health, and may the good Lord bless you.



Sun City Community Association

BULLETIN



VOL. 4 No 6

September 1, 1970

ATTENTION ALL SUN CITY RESIDENTS

The next regular quarterly meeting of the Sun City Community Association will be held Monday, September 14, 1970, at 1:30 PM, at Town Hall South.

There will be a discussion of possible amendments to our present By-Laws and a complete report by the Board covering the past three months; also a report by the Manager.

We urge you to attend and bring your neighbors. It is hoped that all Chairmen of the clubs in Sun City will be there and bring their members along.

ADMITTANCE BY MEMBERSHIP CARD ONLY.

Gordon Evans, Chairman
Public Relations

- - -

Mr. George Shuck resigned from the Board for health reasons and was replaced by Mr. R. J. Meinert on August 17, 1970. The Board of Directors wish to thank Mr. Shuck for his very fine work while on the Board and wish him a speedy recovery. It was the feeling of the Board that his replacement should come from Phase II, in order to give them representation - so welcome aboard Mr. R. J. Meinert - you are now Chairman of the Club Organization Committee and we know you will do a good job for the Association.

- - -

IMPORTANT NOTICE TO ALL CLUB OFFICERS

We welcome your news items for the BULLETIN. Please turn them in not later than the 20th of each month. It would help us a great deal if you would type them in single lines and not more than 1 1/4 inches wide. By doing them this way, most of the time they will fit in the space in the Bulletin and we can use them as written. Please contact Mrs. Rill Abrisch, Town Hall Center office, for further information.

- - -

SEWING CLUB - The sewing technique classes taught by Mrs. Raymond Kruke, will begin on Monday, September 21, 1970. In the sewing room at Town Hall Center on Peoria Avenue.

HAND BELL RINGERS OF SUN CITY - Will begin fall practice for experienced Ringers at 9:00 AM Friday, Sept. 18, Club Rooms at Town Hall Center. A meeting for others with musical backgrounds who are interested in ringing will be held on Thursday, Sept. 24, Same Place and Hour. An interesting fall program is planned with two tentative dates for performing in Phoenix as well as a festival of bells for Sun City.

LAKEVIEW LAPIDARY CLUB - The Lapidary Shop is open from 8:00 AM to 4:00 PM. Monthly meetings are held every third Thursday, beginning with Sept. 17th at 1:30 PM. Meetings are held in the crafts room of Lakeview Center. Lapidary instruction takes place every Thursday afternoon from 1:00 to 4:00 PM and will get under way on Sept. 10th.

RHYTHM CLASS - The Tuesday morning Rhythm Class will resume meetings on Sept. 1, 1970 at Town Hall North, 9:00 AM, for three weeks. Beginning Sept. 22, and every Tuesday thereafter, they will meet at 8:30 AM.

SUN CITY MEN'S CLUB - Meets at 10725 Oakmont Drive, 12 to 5, Monday thru Friday (except holidays); Saturday 11 to 5, with luncheon served. Membership meeting is scheduled for 12:30 PM Saturday, Sept. 5, to approve changes in Articles of Incorporation. Bingo dates during September will be Wednesday, Sept. 2nd, 9th, 16th and 23rd. Town Hall Center auditorium will not be available on Sept. 30th. Community Association Activity Card holders and house guests are invited.

Persons interested in making up bus trips to hockey, basketball or Dog Track during the winter months (both members and non-members) should register their names so they may be called when such trips are arranged. No bus to football games - no buses available or satisfactory tickets. Alex Makarov is Director of Special Events. Write him at Box 519, or phone 933-9974. Mr. Owen Childress, Vice-President, Del E. Webb Development Co., has advised that construction of the new addition to Town Hall North will begin the first week in September.

* * *

I used to like fresh air
When it was there.
And water - I enjoyed it
Til we destroyed it.
Each day the land's diminished,
I think I'm finished.

MOVIES

MOVIES

MOVIES

MOVIES

TOWN HALL SOUTH AUDITORIUM

TUESDAYS

7:30 PM

Sept. 15th - "KISSES FOR MY PRESIDENT"

- For the first time in history, a woman is elected President. Trouble really pyramids for the family - she feels overworked, her husband feels underprivileged, their son becomes a delinquent, and she discovers she is going to have a baby.

Sept. 22nd - "CALL ME MADAM"

- Based on the Leland Hayward stage production, the wonderful musical about an uninhibited Washington hostess who is appointed Ambassador to the grand duchy of "Lichtenburg".

Sept. 29th - "GREEN FIRE"

- Starring Stewart Granger, Grace Kelly, Paul Douglas and John Ericson. A couple of rough-tough mining engineers, by accident, discover a long-forgotten emerald mine. Against the advice of the local priest, they pool their resources to buy equipment to re-open the mine. Complications arise when the mine shaft collapses.

SUN CITY MALE CHORUS - Rehearsals for the 1970-71 musical season of the Sun City Male Chorus will begin on Saturday, Sept. 12, at 8:30 AM in Auditorium "A" of Town Hall Center. This year, as last year, the chorus will be under the very capable leadership of the distinguished director, William Walley.

Preparations are being made for another successful Christmas Concert to be presented together with the Sun City Woman's Chorus on December 13 and 14.

Present members invite new members to come to the first rehearsal on Sept. 12. Men who enjoy singing, who instinctively sing for the love of singing, and who enjoy the sociability and fun engendered by a group of men having like interests, are invited to join the Male Chorus.

SUN CITY WOMAN'S CHORUS - will begin rehearsals on Wednesday, Sept. 9, at 9:30 AM in the Town Hall Center Auditorium. Marion F. Jewell will direct the chorus this year, replacing Jo Gerig who has retired. Mrs. Gerig will remain a member of the chorus and will continue as director of the Handbell Ringers. Mrs. Jewell has been a resident of Sun City and a member of the chorus for the past year and has had considerable experience as a director. Dorothy Giebelstein will again be chorus accompanist. Chorus officers are: Harriet Bush, Chairman, phone 933-6271; Ida Argersinger, Vice-Chmn., 933-6250; and Gladys Queen, Secy-Treas., 933-6035. Women interested in singing three-part music should contact the director, Marion Jewell, 10426 El Capitan Circle, phone 933-9609, or one of the officers.

A THOUGHT

You have never lived a "perfect day" even though you have earned your wage, unless you have done something for someone who will never be able to repay you.

"PROMISE YOURSELF"

- To be strong that nothing can disturb your mind.
- To talk health, happiness and prosperity to every person you meet.
- To make all your friends feel that there is something good in them.
- To give so much time to the improvement of yourself that you have no time to criticize others.
- To be too large for worry, too noble for anger, and too happy to permit the presence of trouble.

SUN CITY SPORTSMAN'S CLUB - NOTE CHANGE OF MEETING PLACE. Will meet Monday, Sept. 21, 9:30 AM, at Lakeview Center, Social Hall #3. This change brought about due to the increase in membership and attendance.

Two very interesting films will be shown: "TO HAVE AND TO HARVEST" - Methods used in today's deer management and many shots of deer and other wildlife.

"KAIBAB BUCK" - This film is a bow and arrow hunt in the famous North Kaibab Forest. It takes you through Navajo and Hopi country. Scenery shots reveal typical deer range and some fine Kaibab Deer. Don't forget the date and new meeting place - bring your wife and outdoor friends. Refreshments will be served.

A man may love a woman even though he hates her cooking, but no man can love a woman's cooking without feeling some sort of tenderness for her.



Sun City Community Association

BULLETIN



Vol. 4, No. 7

October 1, 1970

STELLA S. PRATHER, BELOVED WIFE OF JOHN W. PRATHER, ONE OF OUR DIRECTORS, PASSED AWAY ON SEPTEMBER 15, 1970. OUR SYMPATHY GOES OUT TO JOHN AND HIS FAMILY.

* * * * *

IMPORTANT NOTICE TO ALL CLUBS

IT IS NECESSARY THAT ANY SCHEDULE CHANGES BE GIVEN TO MRS. RILL ABRISCH AT TOWN HALL OFFICE BY THE 15TH OF THE MONTH, IN ORDER TO BE INCORPORATED IN THE NEXT MONTH'S CALENDAR. ANY CHANGES AFTER THE 15TH WILL NOT BE SHOWN ON THE CALENDAR.

* * * * *

SUN CITY ROSE & GARDEN CLUB - Busy days are ahead for the members of the Sun City Rose & Garden Club. On Tuesday, October 6, they will have their fall card party at the Town Hall Center Auditorium from 1:00 PM to 3:30 PM. There will be dessert, table prizes and door prizes. Bring your own cards and play the game of your choice.

On October 9 and 10, they will have a table at the Sun City Merchants Fair, where they will dispense information about roses and gardens in general.

Regular membership meeting will be held on October 12 at 7:30 PM at Town Hall Center Auditorium. Guest speakers will be Mr. & Mrs. James Long of Phoenix who are outstanding Rosarians. This will be the last meeting before the annual Rose Show and anyone wishing information about showing roses is welcome to attend.

The FIFTH ANNUAL ROSE SHOW will be held October 24 and 25 at Town Hall Center Auditorium. Everyone is invited to exhibit their roses. Membership in the Club or the American Rose Society is not required. Specimen roses for the show must be entered before 10:00 AM on October 24. The show will be open to the public on Saturday, Oct. 24, from 2:00 PM to 8:00 PM and on Sunday, October 25, from 10:00 AM to 6:00 PM. Awards will be distributed on Sunday, Oct. 25, at 4:30 PM. Admission is free.

Classes in Flower arrangements will be held Tuesdays, October 13 and 20, at 9:00 AM at the Club Rooms, Peoria Avenue.

FRIENDS OF THE LIBRARY - The first regular meeting of the new season will be held on Monday, October 5th, at 1:30 PM in the Town Hall Center Auditorium. On display will be many of the new books acquired by the library over the summer months, and Miss Dorothy Leber, Head Librarian, of the Sun City Library, will review one of her favorites. The public is cordially invited to all meetings.

SUN CITY CLAY CLUB - Will hold Open House on Sunday, November 1, from 2:00 to 5:00 PM. Members will display their ceramic works of art made since the Club began last January. They will also offer many interesting articles for sale for the benefit of the Club. A cordial invitation is extended to one and all - a good way to get acquainted and to see what can be accomplished in this very popular craft.

Fall activities have already started, with classes for beginners and advanced decorating on Tuesdays, beginning freeform on Wednesday afternoons, and workshops on Wednesday mornings and all day Thursday. A class in intermediate freeform will begin October 16th and new classes for beginners and advanced decorating will begin Oct. 20. There will also be classes on Mondays when a sufficient number enroll. Sign-up sheets are posted on the bulletin board in the club room for those wishing to join classes.

LAKEVIEW CENTER ART CLUB - Will meet Friday, October 2nd, at 1:00 PM. "Introduction to Decoupage" will be given by Mrs. Hershel Palmer, who will show a collection of her work and give a brief introduction to decoupage, both Victorian and Modern. Mrs. Palmer is a newcomer to Sun City from Detroit, Mich. She has taught decoupage for three years and has studied with Marie Mitchell of Detroit and Patricia Nimocks of Louisville, Ky. She is presently teaching at Witch Craft.

SUN CITY ORGAN CLUB - Will meet Wednesday, October 7, at 7:30 PM at Town Hall South. The program will be given by Mrs. George Lovgren, Mrs. Blanche Lesser and Mr. Al Dickey, all members of the club. Membership is open to all Sun City residents.

TOWN HALL LAWN BOWLS CLUB - Will meet on Monday, October 5th, at 3:30 PM, at Town Hall South Auditorium. Nominating Committee will make their report and the time of day for lawn bowling will be given consideration.

* * * * *

Common sense is the knack of seeing things as they are and doing things as they should be.

WEAVERS' GUILD--Monthly meetings are held the first Monday of each month in the craft room at Lakeview Center. Many interesting programs have been planned for the coming season. At the Oct. 5th meeting, Agnes Rominger from Sedona, well known weaver, lecturer and teacher, will give a program on "Color". At the Nov. 5th meeting, there will be an exhibition of hand woven Christmas items, plus an interesting program. Anyone interested in weaving is invited to attend the meetings. Lucia Mysch will give a beginners class in weaving starting in October. Anyone interested, call Vera Cooily 933-8591. The craft room is open each Monday for weavers who wish to work on projects.

SUN CITY MEN'S CLUB - Club rooms, 10725 Oakmont Drive - Meets Monday through Friday, 12 Noon to 5:00 PM; Saturdays 11 to 5, with luncheon served. Membership meeting Saturday, October 10, at 12:30 PM, when candidates for 1971 Board of Directors will be introduced. Bingo dates in October: Wednesday, 14th, 21st, and 28th, Town Hall Center Auditorium. Activity card holders and house guests cordially invited.

The sweetest music we've heard in many a moon is that of carpenters' hammers at work on the new addition. If the progress made to date is any criterion, it should be ready for occupancy within a few weeks.

Unless more interest is shown (by registering names) it is unlikely the Club will sponsor bus trips to various events this fall. If interested, phone 933-9974, so that you may be notified when bus trips are finalized.

SOCIAL NOTICE

Effective October 1st, the usual fall schedule will obtain at all pools - Open 10:00 AM to 6:00 PM, daily and Sundays. There will be no change in therapy pool hours which are 10:00 AM to 6:00 PM daily, Monday through Friday; 10:00 AM to 5:00 PM on Saturday - closed on Sunday.

Mini-Golf, Tennis & Boats will be open from 9:00 AM to 10:00 PM, daily and Sunday.

SUN CITY SPORTSMEN'S CLUB - held their first Fall meeting Monday, Sept. 21. The Fall program proposed for the Club included Auto Emissions Check by Arizona Public Health the last week of September; for October - a display booth at the Country Fair, and a club picnic. A Buffalo Bar-B-Q is planned for November and a Johnny Horizon Clean-up for December.

There were 21 new members and guests at the September meeting. For the information of new Sun City arrivals, the Sportsmen's Club is affiliated with the Arizona Wildlife Federation and the National Wildlife Federation. The wives of male members are associate members, but the Ladies who join the club are non-voting members.

The Club is open to all who have a SCCA Activity Card and are interested in the outdoors, ranging from Bird Watching to Big Game Hunting.

The next meeting of the Club is Monday, October 19, 9:30 AM, at Lakeview Center Social Hall #3, just to the left of the West ramp. Come, attend the meeting as our guest to see if you would like to join us. A Red Cross program in first aid will be given.

MOVIES

MOVIES

TOWN HALL SOUTH AUDITORIUM

MOVIES

MOVIES

TUESDAYS

7:30 PM

October 6th - "THE MERRY WIDOW"

- Starring LANA TURNER. Based on the operetta by Frank Lehár. A rich American widow is invited back to her husband's birthplace by the king, who needs her money. Disgusted by fortune hunters, she heads to Paris for a good time, pursued by the king's nephew.

October 13th - "TRUE GRIT"

- Starring JOHN WAYNE, GLENN CAMPBELL. A spunky teenager, Kim Darby, determined to avenge her father's murder, enlists the aid of a tough, one-eyed marshall, John Wayne. They are also helped by a young Texas Ranger, Glenn Campbell, in tracking down the same killer for a reward.

October 20th - "GREEN FIRE"

- Starring STEWART GRANGER, GRACE KELLY, PAUL DOUGLAS, AND JOHN ERICSON. A couple of rough-tough mining engineers, by accident, discover a long-forgotten emerald mine. Against the advice of the local priest, they pool their resources to buy equipment to re-open the mine. Complications arise when the mine shaft collapses.

October 27th - "CAT BALLOU"

- Starring JANE FONDA, LEE MARVIN & NAT KING COLE. "Cat Ballou" is a classic kooky American comedy. Lee Marvin won an academy award as best actor of the year for his performance as the drunkest gun fighter in the West. Nat King Cole sings "The Ballad of Cat Ballou", providing an amusing musical commentary.

Form Good Habits. They're as hard to break as bad ones.



Sun City Community Association



BULLETIN

Vol. 4, No. 9

December 1, 1970

IMPORTANT

IMPORTANT

IMPORTANT

ANNUAL ELECTION TO THE BOARD OF DIRECTORS

DATE: Thursday, December 3, 1970
TIME: 10:00 AM to 6:00 PM
PLACE: TOWN HALL SOUTH AUDITORIUM

Mark your calendar NOW! Come out and VOTE! Be an active PARTICIPANT, not a spectator. Elect and support your Sun City Community Association Board of Directors for continued progressive and efficient management of the myriad of complex problems faced in the operation of the facilities for all members in this beautiful city. Remember Civic Pride is the only remuneration received by any board member.

NOTE: BRING YOUR CURRENT ASSOCIATION MEMBERSHIP CARD TO VOTE

FIVE DIRECTORS TO BE ELECTED

You may vote by absentee ballot until November 30th if ill or out of Maricopa County on December 3rd.

NOTICE: A SPECIAL ELECTION NEWS BROCHURE HAS BEEN PREPARED AND IS AVAILABLE AT ALL TOWN HALLS, IN THE BUSINESS OFFICE, AND FROM CLUB CHAIRMEN.

THE BOARD OF DIRECTORS AND STAFF OF THE SUN CITY COMMUNITY ASSOCIATION WISHES TO EXTEND TO ALL RESIDENTS AND ASSOCIATES A VERY MERRY CHRISTMAS AND A HAPPY NEW YEAR. MAY YOU HAVE A JOYOUS YULETIDE SEASON WITH PEACE, HARMONY AND LOVE OF YOUR FELLOW MAN PREVAILING.

NOTICE TO ALL CLUBS

PLEASE INFORM THE OFFICE, AS SOON AS POSSIBLE AFTER YOUR ANNUAL ELECTION, THE NAMES, ADDRESSES AND TELEPHONE NUMBERS OF YOUR 1971 OFFICERS, FOR NEW CLUB LIST WHICH WILL BE ISSUED JANUARY 15.

SUN CITY ROSE & GARDEN CLUB - will have its annual Christmas party on Monday, Dec. 14, at 6:30 PM, at Town Hall Center Auditorium.

The Club will furnish Baked Ham and Turkey and the Ladies are to bring potatoes, vegetables, salads, desserts, or whatever else they consider should go with a Christmas Dinner, sufficient for 6 to 8 servings. The men will be charged \$1.00 each. BE SURE TO BRING YOUR OWN TABLE SERVICE. EVERYONE is welcome - whether a member of the club or not. Ladies, will you please advise Miss Edna Volkman, phone 933-2367, or write 9433 - 111th Avenue, what you plan to bring.

ORGAN CLUB - will meet at Town Hall South Wednesday, December 2nd, at 7:30 PM.

Officers for the coming year will be elected. The guest organist will be Bill Dutcher. Mr. Dutcher began his professional career with Horace Heidt and has played for Radio and TV. His program will feature Christmas music, old familiar numbers and popular songs of the day. A social hour will follow the program.

MEN'S CLUB - Meets daily Monday thru Friday in the Club rooms, Town Hall North, 12:00 to 5:00 PM; Saturday 11:00 to 5:00 PM, with luncheon served at 11:00 AM. LATEST PROJECT: To supply meats for baskets to be distributed for Christmas to needy families in El Mirage and Peoria. Donations may be either money or canned meats. It is hoped enough money is received so poultry or a ham may be included in each basket. Checks made payable to "MEN'S CLUB, NEEDY FUND" should be mailed to Box 519, Sun City, or turned in at the Club rooms. December "Games Nite" in Town Hall Center Auditorium will be on December 9th and 23rd ONLY, due to unavailability of auditorium on other Wednesday nights.

FRIENDS OF THE LIBRARY - For the Christmas program, Mrs. Mary Ann Dutton, Music Professor of Glendale College, will present in costume the Chamber Singers, 20 students of the Music Dept., in Madrigals and Christmas Music, a capella. Meeting will begin at 2:00 PM Monday, Dec. 7, in THC Auditorium. Please note later time. The AARP will

(over)

FRIENDS OF THE LIBRARY (continued)
 meet with us for the musical program and
 will be co-hosts for the tea following.
 Coffee, punch, and cookies will be served.

SUN CITY WOMAN'S CHORUS and the SUN CITY
 MALE CHORUS - will present a Christmas con-
 cert at Town Hall South Auditorium on Sunday
 December 13th, and Monday, December 14th,
 at 8:00 PM.

The combined choruses number over 100
 voices. The Woman's Chorus is directed by
 Marion Jewell with Dorothy Giebelstein as
 the accompanist. The Male Chorus is
 directed by Willis Walley, with Esther Weiss
 and Elizabeth Clifton as the accompanists.

The concert will again consist of an
 interesting program of numbers by each of
 the choruses and will conclude with Handel's
 Messiah being sung by the combined choruses.

For \$1.00 donations each, tickets may be
 obtained from members of the choruses, and
 will be available at the South auditorium
 on the concert evenings.

SUN CITY SYMPHONY ORCHESTRA - HOLDERS OF
 SEASON TICKETS, PLEASE NOTE:

The concert scheduled for evening of Sun-
 day, December 20, at Town Hall South, will
 start at 8:15 PM, rather than the usual
 8:00 PM. An additional musical treat, in
 keeping with the Season, will precede the
 Symphony Concert. Please note the change
 in time.

FEDERATED WOMAN'S CLUB OF SUN CITY - Founders
 Day Anniversary Tea will be held in Town
 Hall Center on Sunday, Dec. 6th, from 2 to
 4 o'clock. All members are invited, espec-
 ially Charter members. Our State President,
 Mrs. A.W. Spence, and Mrs. Clarence Prather,
 Central Distr. President, will be present;
 also Mrs. Wm. Wade, who helped organize Sun
 City Federated Woman's Club.

SUN CITY SPORTSMEN'S CLUB - An election for
 three new Board members resulted in John
 Anderson, John Doremus and Charles Funden-
 berg being elected to serve for three years
 starting January 1st. The Board of nine
 members will choose the new Chairman for
 1971 at the Board meeting December 7th.

Please note - the Archery Range has been
 moved to Town Hall Center. Archers can use
 it anytime, but those wishing instruction
 or who have never done Archery, but would
 like to try it, John Bogar will instruct
 every Thursday from 9:00 to 10:00 AM.

The Sportsman's Club tries to keep Sun
 City clean by picking up the litter twice
 a year. The 4th litter pickup will be
 December 14, starting at 8:00 AM and will
 last about two hours. At least 40 people
 are needed to help so that our town will be
 clean for Christmas. Anyone who would like
 to help, call either Franklin Rose, 933-7317
 or Harry Kieling, 933-2946, and they will
 assign you to a short section close to home.

Anyone interested in Trap Shooting? Our
 trap shooters use the Peoria Rod & Gun Club
 range every Wednesday at 9:00 AM. For
 further information, call Dr. Earl Blair,
 933-2664.

The next meeting of the Sun City Sports-
 men's Club will be December 21, 9:30 AM,
 at Lakeview Center, Social Hall #3. Bring
 your wife, neighbors, or anyone interested
 in the outdoors. Refreshments served.

FRIENDS OF CHAMBER MUSIC - Last concert of
 the 1970 Season will be Sunday at 3:00 PM
 November 29, 1970, at the United Presbyter-
 ian Church, 103rd & Alabama, with Dr. James
 Barber, violinist; Dr. Gordon Epperson,
 cellist, and Dorothy Beason, lyric Soprano.
 Program will consist of violin and cello
 duo's by Boccherini, Ravel, Kodaly, and
 songs by Bach and Vivaldi.

MOVIES

MOVIES

MOVIES

MOVIES

MOVIES

TOWN HALL SOUTH AUDITORIUM

TUESDAYS

7:30 PM

ORGAN CONCERT AT 7:00 PM - BLANCHE E. LESSER

- December 1st - "MACKENNA'S GOLD" - With Gregory Peck, Keenan Wynn, Lee J. Cobb,
 and others. This is a story of adventure, but
 it is also a story of man's hunger for gold.
- December 8th - "SHOW BOAT" - Starring Ava Gardner, Joe E. Brown, Agnes Moore-
 head and William Warfield. A colorful story
 of a group of entertainers who travelled the
 Mississippi River on a showboat at the turn of
 the century.
- December 15th - "TOBY TYLER" - Starring Kevin Corcoran, Henry Galvin, Gene
 Sheldon and "Mr. Stubbs". A boy, a scene-
 stealing chimpanzee, and a small traveling
 circus at the turn of the century.
- December 22nd - "RHAPSODY IN BLUE" - Joan Leslie, Oscar Levant, Chas. Coburn and
 Julie Bishop. George Gershwin's career, from
 New York's East Side to the Music Hall and
 concert stages of the world.
- December 29th - "BRIGHTY OF THE
 GRAND CANYON" - Starring Joseph Cotton, Pat Conway, Karl Swenson
 as Theodore Roosevelt, and "Brighty", the donkey.
 The story of a shaggy burro with a natural
 instinct for discerning good and bad in human
 beings.

PROPOSED PRESENTATION TO SUN CITY TOWN HALL CENTER
MEMBERS OF AGREEMENT SUBMITTED BY DEL E. WEBB DEVELOPMENT
CO. FOR PROVIDING ADDITIONAL GROUNDS AND FACILITIES, AND
ALTERATIONS AND ADDITIONS TO PRESENT TOWN HALL CENTER FOR
ADDING 1,700 RESIDENCES BEYOND PRESENT CONTRACT OF 3,500.

I. REASONS FOR MEETING AND PROPOSAL

PRESIDENT'S INTRODUCTION

In our May Town Hall Center Corporation meeting and subsequent newspaper articles, you were advised of negotiations being carried on between the Del E. Webb Development Co., and Town Hall Center. You were told that the Webb Company expect to build approximately 1,700 more residences in new units South of Peoria Avenue in addition to the 3,500 residences being attached to Town Hall Center under the present agreement.

In their planning they had set aside about seven acres at 107th Avenue and Mountain View Road for additional recreational facilities. They have however, been very anxious to avoid building another separate recreation center serving only the new units to be built, thus compounding the problems that now exist with Community Center and Town Hall Center operating independently and with separate memberships. As a result they ask us if Town Hall Center would consider the combining of the new facilities under the management and ownership of Town Hall Center on consideration of adding the additional 1,700 residences to the 3,500, thus making a total then of 5,200 so a negotiating committee was appointed from your Board to try and work out with the Del E. Webb Development Co., a fair and equitable solution for presentation to the Town Hall Board and, if approved by the Board, to the Town Hall members for vote.

On August 22, 1966, Del E. Webb Development Co., officials presented to our negotiating committee an agreement for consideration of what they propose to do if Town Hall Center will accept the 1,700 additional residences. This agreement is very much in line with the recommendations submitted to them by our negotiating committee.

We are here today to present this agreement to you for your consideration.

I do want to comment on the negotiations. Hundreds of hours were spent in investigations and conferences with many Town Hall clubs and people and in visitations to other retirement facilities in order to most accurately determine our needs

now and in the future and the best solutions for meeting those needs. We believe the Webb proposed agreement is not only fair and equitable but also meets our recommendations for future needs and expansion in a very excellent manner. The proposed alterations and additions will be of great benefit to all present and future members of Town Hall Center and Sun City, Arizona.

As the result of the above efforts the committee can now inform the residents of Town Hall Center of their results. This will be done in a brief resume in Exhibit A and Exhibit B following:

MODIFICATIONS AND ADDITIONS TO TOWN HALL FACILITIES - 107th AND PEORIA AVENUE

1. LIBRARY: Library to be relocated in the present sewing room space. Part of the dark room space to be partitioned off for a library storage room.
2. SEWING ROOM: Enlarge the sewing room by installing a pair of swinging doors into the present ceramics and art room. Replace and build additional storage cabinets in the storage room.
3. DARK ROOM: Relocate partitions, door and cabinets in the dark room.
4. REST ROOMS AND SHOWER ROOMS: Remodel present shower room. The janitor storage and basket storage area will be partitioned to enlarge the shower and dressing facilities by eight shower and dressing spaces. Add adequate water heater in the janitor storage area.
5. COPPER ENAMELING - MOSAICS - JEWELRY MAKING, ETC.: The storage room partitions between present library and enameling room will be removed. Storage shelving will be added along the north and east walls.
6. WOODWORKING: Install a door in the partition between the present woodworking shop and lapidary storage room and use all of the combined facilities for woodworking.
7. ARTS AND CRAFTS BUILDING: Construct a new building with underwriter's approved fire sprinkler system, adequate air conditioning, approximately 32' x 125', to keep all arts and crafts facilities at present Town Hall Center location. The new structure will provide space and facilities for:
 - A. Lapidary room;
 - B. Ceramics and firing room;
 - C. Art and music room;
 - D. Janitor and equipment storage.
8. SHUFFLEBOARD: New canopies will be built at the shuffleboard courts with revised lighting and equipment racks.
9. SNACK BAR: A snack bar will be located east of the existing swimming pool. The building to have necessary plumbing and electrical facilities for a short order snack bar. Kitchen equipment to be furnished by Town Hall Center.
10. No repainting will be done except that required by relocation of equipment or partitions.

NEW COMMUNITY AND RECREATION FACILITIES AT 107th AVENUE AND MOUNTAIN VIEW ROAD

1. NEW AUDITORIUM: Construct an auditorium building with adequate air conditioning to seat between 1,000 and 1,200 people, with a stage dressing rooms, chairs and a projection booth. Covered and open terraces will overlook the pool area for dining, dancing and lounging. An underwriter's approved fire sprinkler system will be installed in this building.
2. SWIMMING POOL: A swimming pool will be constructed in a completely landscaped, recessed area, with kool-decking surrounding the pool. Cabanas will be located in the southwest corner of the pool area, with toilet, shower room and basket storage building on the north side. Certain pool and terrace furniture will be provided. The recessed pool area will be accessible by two ramps from the terraces. The pool equipment will be located in the equipment area referred to in paragraph 7 of this exhibit.
3. HEALTH AND EXERCISE FACILITIES: A building with adequate air conditioning will be constructed to enclose a therapeutic pool, exercise room with certain equipment, toilet facilities and dressing rooms. This building will also include a kitchen facilities for serving catered banquets or parties. A snack bar space with necessary plumbing and electrical will be provided, kitchen equipment to be furnished by Town Hall Center. This building will have an underwriter's approved fire sprinkler system.
4. BOWLING GREEN: A bowling green with proper lighting will be provided.
5. SHUFFLEBOARD: Twelve shuffleboard courts with canopies, lighting and equipment racks will be provided. Toilet facilities will be located in a building between the shuffleboard courts and the bowling green, along with a general storage room for use in connection with the recreation area.
6. CROQUET: Four croquet courts will be located in the recreation area.
7. EQUIPMENT STORAGE: A recessed equipment yard accessible only by a service road from Mountain View Road. The pool equipment will be located in this equipment yard. A covered area will be provided for equipment storage.
8. PARKING: Parking area will be provided with ingress and egress to and from 107th Avenue and Mountain View Road.

Following Exhibit A and Exhibit B, herein is a breakdown of our present Town Hall area and a breakdown of the New Proposed Additions.

APPROX. PRESENT TOWN HALL AREAS

BUILDINGS

North - Arts and Crafts	2,904 Sq. ft.	
South - " " "	2,728	
Showers and Janitor Room	1,204	
Auditorium	7,600	
Lounge and offices	1,800	
Card rooms	2,240	
	<hr/>	
TOTAL SQUARE FOOT BUILDINGS		18,476 sq. ft.

GROUNDS

Swimming pool	3,845 Sq. ft.	
Concrete around pool	15,694	
Concrete patio and theatre area	16,457	
Bowling Green	14,400	
Shuffleboard Court	5,940	
Parking area	30,618	
Walks	18,586	
	<hr/>	
Lawns & Shrubs	84,547	105,540 sq. ft.
		<hr/>
TOTAL TOWN HALL AREA (PRESENT)		208,563 sq. ft.

APPROX. PROPOSED NEW ADDITIONS

BUILDINGS

I. TOWN HALL CENTER LOCATION *

New Arts & Crafts Bldg.	4,000 sq. ft.	
Snack Bar	600	
		4,600 sq. ft.

II. NEW RECREATION CENTER

Auditorium	9,700 sq. ft.	
Toilets & equip. storage	1,880	
Exercise & kitchen bldg.	4,960	
Pool equip. bldg.	684	
		17,224 sq. ft.
New site bldgs.		17,224 sq. ft.
TOTAL NEW BLDGS. PROPOSED		21,824 sq. ft.

GROUNDS & OUTSIDE FACILITIES

New Swimming Pool	7,293 sq. ft.	
Lawn Bowling area	22,500	
Shuffleboard	7,995	
Pool terrace area	22,977	
Terraces	9,450	
Parking	62,200	
Walks	16,520	
Service Yard	3,855	
Service road	9,300	
Shrubs & Lawns	139,211	
		301,301 sq. ft.
TOTAL OUTSIDE FACILITIES		301,301 sq. ft.
TOTAL PROPOSED BUILDINGS		17,224
TOTAL AREA NEW SITE		318,525 sq. ft.

* Figures do not include shuffleboard canopies or remodeling of Arts & Crafts rooms and shower additions.

On September 1, 1966 your Town Hall Board of Directors voted favorably on this Agreement and on certain amendments and changes in the By-Laws and Articles of Incorporation which are required to proceed with this agreement. While the Articles of Incorporation and the By-Laws give the Town Hall Board the authority to enter into contracts or agreements, in order to increase the residential areas or number of residences attached to Town Hall Center these By-Laws and Articles of Incorporation changes have to be made.

Motion was made and seconded that the Articles of Incorporation be amended as follows:

"ARTICLE I. The name of this corporation shall be SUN CITY TOWN HALL CENTER and its principal place of business shall be at Sun City, Maricopa County, Arizona, but the board of directors may designate other places within the State of Arizona where other offices may be established and maintained and corporate business transacted. Members of the corporation shall be residents of Sun City Units 2,

3, 4, 5, 6 and such additional geographical designations as may be formed, created or zoned within the bounds of Peoria Avenue, 99th Avenue, Olive Avenue and a boundary line west of 111th Avenue as shown on a map of Sun City, Arizona, identified as Exhibit "C" attached hereto." (Explained later)

ARTICLE III, Paragraph 2. Amend to read: "2. To coordinate, implement and aid the various recreational and social clubs within Units 2, 3, 4, 5, 6 and such additional geographical designations as may be formed, created or zoned within the bounds of Peoria Avenue, 99th Avenue, Olive Avenue and a boundary line west of 111th Avenue, and shown on map of Sun City, Arizona, identified as Exhibit C.

ARTICLE III, Paragraph 3. Amend to read: "3. To promote cooperation in all matters of interest and benefit to the residents of Units 2, 3, 4, 5, 6 and such additional geographical designations as may be formed, created or zoned within the bounds of Peoria Avenue, 99th Avenue, Olive Avenue and a boundary line west of 111th Avenue, as shown on map of Sun City, Arizona, identified as Exhibit C."

The following changes and/or amendments to the By-Laws were approved:

In all instances where reference is made to "Units 2, 3, 4, 5 or 6" or "Units 2, 3, 4, 5 and 6", such geographical identifications shall be changed to read "Units 2, 3, 4, 5, 6 and such additional units or other geographical designations as may be formed, created or zoned within the bounds of Peoria Avenue, 99th Avenue Olive Avenue and a boundary line west of 111th Avenue."

ARTICLE III, Section 2. Amend the first paragraph by adding the following sentence: "No member shall be denied the use of any facility of Sun City Town Hall Center, even though he has no membership in any recognized club and no recognized club shall have any rule or regulation prohibiting the use of any facility by such member."

ARTICLE III, Section 3. Add following sentence to paragraph 1: "This assessment will entitle each member to a membership card in all Town Hall activities."

BALLOT

"The proposed contract between the Del E. Webb Development Company and the Sun City Town Hall Center for the expansion of the area to be serviced by the said Town Hall Center from the present 3,500 Units to 5,200 Units and the recreational facilities be expanded as set forth in Exhibits "A" and "B" is approved."

FOR

AGAINST

A YES VOTE will include the necessary changes to our Articles of Incorporation and By-Laws which will have to be amended to honor the proposal.

SUN CITIZEN
NOV. 10, 1966

Ground Broken For Complex

Another mile-stone was reached Monday, when Del E. Webb, president and chairman of the board of the Del E. Webb Corporation, turned over the first shovelful of earth, which indicated the start of the building for the new

Town Hall Recreation Center. Also using the silver plated special shovel to help along the project were John Meeker, vice president and general manager of the Community Development Division for the Del E. Webb Corporation and president of the Del E. Webb Development Company in Sun City; Owen Childress, vice president and project manager of the Webb Development Company; and Burr Welch, president of Town Hall Corporation. The shovel with a suitable inscription was then presented to Mr. Welch and will be given a place of honor in the Town Hall.

Present plans call for work on the new complex to start in January, 1967 with the possible completion by May 15. A progress chart (billboard) will be installed on the site to keep residents up to date on its progress.

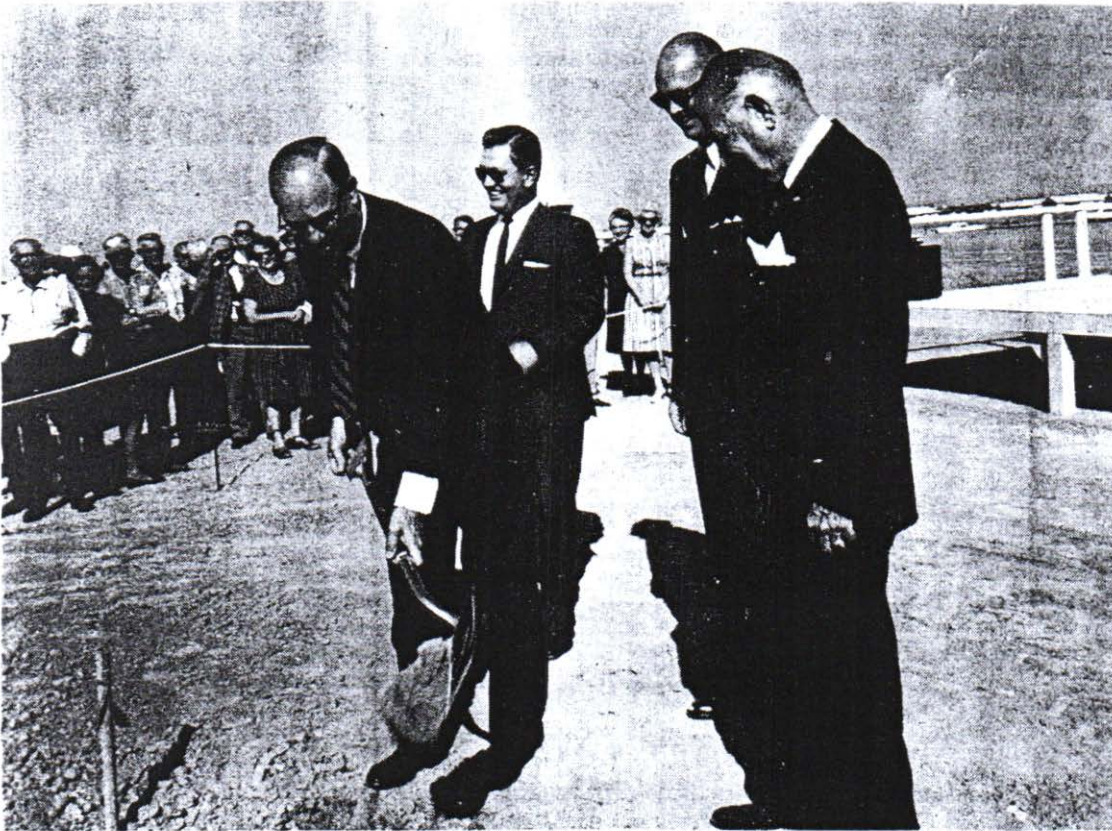

GROUNDBREAKING — Ground was broken on Monday, Nov. 14, for the new Town Hall Complex. Del E. Webb, turns the first shovel full of

earth. With Mr. Webb are left, John Meeker, and Owen Childress, of the Webb Company and Burr Welch, Town Hall president. Reckner Photo

1961

FIRST ANNUAL EASTER SUNRISE SERVICE

DEL WEBB'S **Sun City** TOWN HALL

6:00A.M.
(on Patio, weather permitting)

ORGAN PRELUDE
Easter Selections

TRUMPETEERS
Lindy Kiser, Craig Wacker, Jim Wagoner

Call to Worship All Standing
"Praise God From Whom All Blessings Flow"

INVOCATION
The Rev. E. Duane Thistlewaite All Standing

CHORUS
"Teach Us to Pray" Daniel H. Johnson

WELCOME
Mr. T. G. Austin
"Hallelujah, Christ Arose" Bonar-Lowry
Mrs. Mamie Hite, Mrs. Otis Ferrell and Chorus

SCRIPTURE READING
Dr. S. A. Allen
"I Know That My Redeemer Liveth" Handel's "Messiah"
Mrs. Eugene Gilbert

"Because He Rose" by Peter Marshall
Pastor Albert B. Schwertz

"In the End of the Sabbath" Oley Speaks
Mrs. Stephen Quayle and Chorus

SERMON
By the Dawn's Early Light The Rev. Walter W. Witt

CHORUS
"Christ Our Passover" Daniel H. Johnson
Closing Prayer (All Standing) BENEDICTION

POSTLUDE
Director of Chorus — Otto Highfield
Organist — Mrs. Albert B. Schwertz Pianist — Mrs. Otto Highfield

Sun City is just 12 miles Northwest of Phoenix out Grand Ave.
EVERYONE IS INVITED TO ATTEND

Sun City Town Hall Center

Operating Statement Jan. 1st to Dec. 31st, 1965

Cash on Deposit Jan. 1st, 1965			\$ 2,316.61
Accounts Receivable from Webb Jan. 1st			<u>10,571.91</u>
			\$ <u>12,888.52</u>

Receipts:

Membership Dues 1965	\$ 71,314.41		
Membership Dues 1966	<u>12,102.33</u>	\$ 83,416.74	
Hall Rentals		1,319.01	
Interest Received		1,288.99	
Special Entertainment-Luaus		389.14	
Other Income		<u>330.71</u>	<u>86,744.59</u>
			\$ 99,633.11

Expenses:

Payroll - Office	\$ 4,556.74		
- Janitorial	13,784.36		
- Grounds	<u>6,545.83</u>	\$ 24,886.93	
Utilities: Trash	\$ 180.00		
Water	2,545.07		
Sewer	189.60		
Telephone	351.91		
Electric	6,112.11		
Gas	<u>1,274.17</u>	10,652.86	
Supplies - Office & Operating		3,395.95	
Insurance		4,158.56	
Repairs & Maintenance		3,358.60	
Payroll Tax & Corp. Fee		359.04	
Excise Tax		10,647.00	
Real Estate Tax		2,607.86	
Club Expenses		112.01	
Printing & Stationery		936.33	
Postage		388.80	
Professional & Legal		958.50	
Publicity		<u>299.47</u>	<u>62,761.91</u>
Operating Balance			\$ 36,871.20

Capital Expenditures:

Sprinkler System on a/c	\$ 13,660.00
Exhausts in Card Rooms	308.00
Audio System Installations	369.78
Furniture & Office Machines	1,658.49
Other Equipment	<u>2,358.88</u>
	\$ 18,355.15

Sun City Town Hall Center

Balance Sheet as of December 31st, 1965

Current Assets:

Cash on Hand and in Banks \$ 18,711.61

Fixed Assets:

Building Improvements \$ 14,337.78
Office Furniture 2,486.24
Other Equipment 3,442.05
\$ 20,266.07

Total Assets \$ 38,977.68

Current Liabilities:

Payroll Taxes \$ 248.44

Capital Accounts:

Property Bal. 1/1/65 \$ 1,858.04
Operating Balance Yr.to date 36,871.20
\$ 38,729.24

Total Liabilities \$ 38,977.68

*Calh*BUDGET1966 - with Billiard Hall

SALARIES AND WAGES

General Manager	10,500
Full time and Part Time Secretaries	4,800
	2,400
Maintenance Men	
Kirchner	5,510
Willis	5,300
Hawkins	3,750
Beeler	3,750
Additional Man	3,750
Swim- Rosenthal	1,000
Boals	800
F.I.C.A.	1,209
C.S.U.I.	970
F.U.I.	295
W.C.I.	687
Operating Supplies (Pool, Plants, Rock Shop, Wood Shop, Uniforms, Soaps, etc.)	7,000
Legal Fees	1,500
Utilities	10,900
Postage	750
Stationery, Printing and Office Supplies	788
Grounds Maintenance	9,600
Miscellaneous, Piano Tuning, Mileage Election Expense	1,000
Taxes - Real Estate & Pers. Prop.	9,400
Lawn Bowling Green Maint.	4,500
Insurance	5,000
Miscellaneous	2,000
Equipment	

Estimated

\$ 97,159

(OVER)

BUDGET

1966 Budget - without Billiard Hall

SALARIES AND WAGES

General Manager 10,500

Full time and Part Time Secretaries 4,800

2,400

Maintenance Men

Kirchner 5,510

Willis 5,300

Hawkins 3,750

Beeler - 3,750

Swim - Rosenthal 1,000

Boals 800

F.I.C.A. 1,075

C.S.U.I. 850

F.U.I. 260

W.C.I. 612

Operating Supplies (Pool, Plants,
Rock Shop, Uniforms, Soaps, etc.) 6,300

Legal Fees 1,500

Utilities 9,975

Postage 750

Stationery, Printing and Office Supplies 788

Grounds Maintenance 9,300

Miscellaneous, Piano tuning, Mileage,
Election Expense, etc. 1,000

Taxes- Real Estate and Pers. Prop. 8,600

Lawn Bowling Green Maintenance 4,100

Insurance 4,565

Miscellaneous 2,000

Estimated \$ 89,485

SUN CITY TOWN HALL - BudgetINCOME AND EXPENSE BUDGET

YEAR 1966

Salaries & Wages:

Manager	\$ 12,000.
Office (2 full time - 1 part time)	8,800.
Custodians (including over-time and extra part-time help)	13,500.
Pool Monitors (est. @ 60 hours per week @ \$1.50 per hour)	4,800.
Grounds maintenance	<u>7,200.</u>

TOTAL SALARIES & WAGES

\$ 46,300.

Payroll Taxes (Social Security, Work-
men's Compensation & Unemployment
Insurance)

2,500.

TOTAL PAYROLL & PAYROLL TAXES

\$ 48,800.

Utilities

Electricity	6,700.
Gas	1,200.
Telephone (includes adding another line)	600.
Trash	180.
Sewer	190.
Water	2,930.
Rural Fire Protection	<u>200.</u>

UTILITIES TOTAL

12,000.

Supplies

Office	900.
Other	<u>2,000.</u>

SUPPLIES TOTAL

2,900.

Repairs & Maintenance

Buildings (normal upkeep)	2,400.
Janitorial Equipment	150.
Grounds	650.
Shop Equipment	<u>1,600.</u>

REPAIRS & MAINTENANCE TOTAL

4,800.

Taxes

Property tax

3,000.

(OVER)

1966 SUN CITY TOWN HALL BUDGET - Continued

Insurance

Public Liability	\$ 288.	
Fidelity Bonds on Employees	55.	
Movie Equipment	15.	
Buildings & Equipment	<u>2,462.</u>	
INSURANCE TOTAL		\$ 2,820.

Other Expenses

Club Expense	100.	
Corporation Fee (annual)	5.	
Stationery & Printing	1,200.	
Postage	500.	
Publicity	600.	
Legal & Accounting	750.	
Interest	350.	
Miscellaneous	<u>250.</u>	
OTHER EXPENSES TOTAL		3,755.

Capital Improvements

Balance due in 1966 on sprinkler System	7,200.	
Bowling Green renovation	1,500.	
Other - estimated	<u>800.</u>	
CAPITAL IMPROVEMENTS TOTAL		9,500.

"Reserve for Major Repairs and Replacements"

Buildings(20 year estimated remaining life)	9,748.	
Air cond. equip. 5-yr remaining life	3,257.	
Shop Equipment " " "	600.	
Furniture & Fixt. " " "	<u>2,000.</u>	
RESERVE TOTAL		<u>15,605.</u>

GRAND TOTAL - Expenses and Reserve \$103,180.

Income

Membership Fees (5,000 @ \$20.00)	\$100,000.	
Other (commissions, fees & int.)	<u>2,450.</u>	
INCOME TOTAL		\$102,450.

Estimated Cash on Hand at 1-1-66 (not including membership fees prepaid for part of the coming year) 10,000.

TOTAL FUNDS AVAILABLE \$112,450.

SUN CITY TOWN HALL CENTER

BALANCE SHEET as of AUGUST 31, 1966

CURRENT ASSETS:

Cash on Hand and in Banks	\$ 47,901.19	
		\$ 47,901.19

OTHER ASSETS:

Deposit Premium - Ind. Comm.	195.00	
Prepaid Insurance	<u>530.07</u>	
TOTAL OTHER ASSETS		725.07

FACILITIES:

Land	\$ 74,550.00	
Buildings	275,115.00	
Furniture & Equip,ent	58,625.36	
Land Improvements	<u>42,000.00</u>	
	\$450,290.36	
Less Deprec. Reserves	<u>(32,984.54)</u>	
Total Facilities		\$417,305.82
TOTAL ASSETS		<u>\$465,932.08</u>

CURRENT LIABILITIES:

Advance Assessments	\$ 4,224.88	
Payroll Taxes	<u>881.44</u>	
		\$ 5,106.32

OPERATING BALANCE:

Balance Jan. 1, 1966	\$416,208.86	
Balance 1/1 to 8/31/66	<u>44,616.90</u>	
Total Balance Aug, 31		\$460,825.76
Total Liabilities		\$465,932.08

SUN CITY TOWN HALL CENTER

OPERATING STATEMENT Jan. 1, to Aug. 31, 1966

INCOME:

Assessments 1966	\$ 95,287.15	
Hall Rentals	2,053.07	
Interest Received	747.33	
Other Income	<u>39.26</u>	
TOTAL INCOME		\$ 98,126.81

EXPENDITURES:

Salaries & Wages	\$ 23,735.34	
Grounds Maintenance	<u>3,737.50</u>	
		+ 27,472.84
Payroll Taxes		1,832.83
Repairs & Maintenance - ordinary		2,412.25
Repairs - Major	8,195.25	
Paid by Del E. Webb	<u>(4,097.62)</u>	4,097.63
Grounds & Lawn Bowl Expense		1,298.62
Club Expense		199.98
Utilities		7,773.56
Operating Supplies		1,703.86
Corporation Fee		5.00
Insurance		1,873.65
Office Supplies & Expense		1,176.62
Printing & Stationery		427.28
Postage		252.30
Legal & Professional		1,142.75
Publicity		235.56
Interest Paid		99.02
Executive Travel & Expense		1,306.16
Contribution		<u>200.00</u>
TOTAL EXPENDITURES		\$ <u>53,509.91</u>
Operating balance		\$ 44,616.90
Capital Expenditures not included in above		\$ 7,685.64
Balance on sprinkler system	\$ 2,291.00	
Shop & Lawn Equipment	3,493.17	
Office Equipment	<u>1,901.47</u>	
		\$ 7,685.64

TOWN HALL ESTIMATED ANNUAL EXPENSE BUDGET
FOR CONSIDERATION OF TOWN HALL FINANCE COMMITTEE

Payroll:

Salaries - Manager, full time; and secretary, part time; bookkeeper, part time; and office assistant part time; combined	\$ 9,600.00	
Wages - 4 part time maintenance men for grounds	4,800.00	
3 part time maintenance men for buildings	3,600.00	
3 part time maintenance men for equipment	3,600.00	
4 part time men for guards and miscellaneous services	4,800.00	
Payroll taxes and insurance	<u>3,500.00</u>	\$29,900.00

Property Taxes

2,750.00

Insurance - fire, etc., vandalism, pub. liab. and property damage

3,000.00

Repairs

4,800.00

Utilities:

Electricity	7,000.00	
Gas	1,800.00	
Water	2,000.00	
Garbage Service	150.00	
Sewer	150.00	
Telephone	240.00	
Rural Fire Protection	<u>200.00</u>	11,540.00

Operating Supplies

5,000.00

Office Supplies - postage, printing, etc.

600.00

Miscellaneous General Expenses

750.00

TOTAL - excluding depreciation 58,340.00

Depreciation:

Buildings (on valuation of \$250,000 over 25 year life)	10,000.00	
Furnishings and office equipment (value \$40,000 over 10 year life)	4,000.00	
Shop and yard equipment (value \$30,000 over 10 year life)	<u>3,000.00</u>	<u>17,000.00</u>

TOTAL EXPENSES 75,340.00

NOT INCLUDED ABOVE

Replacements ???

2,500.00

Capital Expenditures (additions) ???

3,500.006,000.00

GRAND TOTAL

\$81,340.00

PROJECTED COSTS OF OPERATING TOWN HALL

	<u>By Webb</u>		<u>By Martin Coniff</u>	
Salaries:	\$ -	\$ -	\$ -	\$ 9,600
Manager			3,600	
Secretary - part time			1,800	
Bookkeeper - part time			2,400	
Office Assistant - part time			<u>1,800</u>	
Labor:				
4 Maintenance Men		15,974		16,800
4 part time Ground Maintenance			4,800	
3 part time Building Maintenance			3,600	
3 part time Equipment Maintenance			3,600	
4 part time Guards			4,800	
Supplies:		804		8,600
Grounds			2,000	
Custodial - Building Supplies	300		3,000	
Swimming Pool	504			
Recreation and Activity Supplies and Repairs			3,600	
Utilities:		12,644		8,800
Water	4,216		2,400	
Gas	1,343			
Electricity	6,905			
Heat and Light			6,000	
Telephone			400	
Sewage	-		-	
Garbage	180		-	
Insurance:		2,868		1,500
Taxes:		2,424		7,000
Real Estate			3,000	
Payroll and Workmens' Compensation			3,500	
Miscellaneous			500	
TOTAL - and Sub-Total for Martin Coniff		34,714		56,500
Add Depreciation:				17,000
Buildings (\$250,000 - 25 year life)			10,000	
Furnishings (\$30,000 - 10 year life)			3,000	
Equipment (\$15,000 - 10 year life)			1,500	
Replacements and Improvements			2,500	
		<u>34,714</u>		<u>73,500</u>
	TOTALS	<u>\$34,714</u>		<u>\$73,500</u>

TOWN HALL ESTIMATED ANNUAL INCOME BUDGET
FOR CONSIDERATION OF TOWN HALL FINANCE COMMITTEE

Assumptions:

Income from operation of activities at Town Hall during the years 1962 and 1963 have produced net profit of a few hundred dollars per year. The amount is not considered sufficient to consider in forecasting future income under local ownership.

For the present, at least, we are assuming that the area to be served by Town Hall will consist of Units 2, 3, 4 and 5 - containing, in all, 2,470 housing units.

It appears reasonable to assume that the percentage of annual assessments which will be currently collected will range between 90% and 98%. Obviously the smaller the population in the area to be served, the higher will the assessments have to be; and this could present a problem in collections. On the other hand, if the population of the area becomes too large, the Town Hall facilities will become so over-crowded that perhaps many of the residents will refuse to pay their assessments in protest. A reasonable mid-point is required for the best prospects of satisfied Town Hall members and the maximum in current collection of assessments at all times.

There are three factors which will influence Town Hall income, and which cannot be determined precisely at present. One of our jobs will be to approximate them as closely as we can. They are:

1. The average number of residents per housing unit, which may vary slightly from time to time.
2. The number of delinquencies.
3. The amount of annual assessment per resident.

There is attached a schedule showing an assortment of combinations of the three factors mentioned above and the resulting annual income to Town Hall in such cases. Our principal task in forecasting the income will be to decide upon the most highly probable combination of these factors. The 20% Federal Tax on these assessments is disregarded, as it goes out of the Town Hall Treasury nearly as soon as it comes in.

TOWN HALL ESTIMATED ANNUAL INCOME BUDGET

FOR CONSIDERATION OF TOWN HALL FINANCE COMMITTEE

<u>Assessment per person</u>	<u>Persons per unit</u>	<u>90% current</u>	<u>92% current</u>	<u>94% current</u>	<u>96% current</u>	<u>98% current</u>
\$16.00	1.7	\$60,466	\$61,809	\$63,153	\$64,497	\$65,840
17.00	1.7	64,248	65,675	67,103	68,531	69,959
18.00	1.7	68,027	69,536	71,024	72,559	74,016
16.00	1.8	64,022	65,445	66,867	68,290	69,713
17.00	1.8	68,024	69,535	71,047	72,559	74,071
18.00	1.8	72,025	73,626	75,226	76,827	78,427
16.00	1.9	67,579	69,081	70,583	72,084	73,586
17.00	1.9	71,803	73,239	74,675	76,111	77,547
18.00	1.9	76,027	77,716	79,406	81,095	82,785
16.00	2.0	71,136	72,717	74,298	75,878	77,459
17.00	2.0	75,582	77,268	78,941	80,621	82,300
18.00	2.0	80,028	81,806	83,585	85,363	87,142

TOTAL VOTES CAST 1.

OFFICIAL BALLOT

SUN CITY TOWN HALL CENTER, INC.

DECEMBER 7, 1965

FOR PRESIDENT

Vote For One Only

599 Herbert F. Martin

721 Burr O. Welch

1320 _____

FOR VICE PRESIDENT

Vote For One Only

690 William A. Chapman, Jr.

585 William J. McDonnal

FOR SECRETARY

Vote For One Only

472 Carl J. Baumgartner

827 Louise F. Poehls

FOR TREASURER

Vote For One Only

473 C. D. Glenn

833 Bertha A. Roberts *

FOR DIRECTORS

Vote For Not More Than Seven

708 R. Glenn Daugherty

701 T. Karl Dimmitt

783 Ruth S. Finch

751 Forrest H. Fullerton

470 George H. Garside

657 David H. Gerig *

821 Earl M. Holmes *

598 Olaf W. Osnes

1048 Taylor Smith *

814 Leland T. Teal

763 Clyde P. Wells

603 Trevor W. White

C. D. Glenn

RIL ABRISCH

H. S. MARSHALL

* Incumbent

HAWAIIAN LUAU

TOWN HALL CENTER

OCT. 18th, 1965

Celebrating the Start of the Town Hall Center Social Season.
For 1965-66.

Three and one half hours of

FUN FOOD FROLIC

5:30 P.M. SOCIAL HOUR: Meeting New and Old Friends around the
Hawaiian Punch Bowls and watching the KANE-WAHINE DANCERS
PERFORMING UNDER THE PALM TREES.

6:30 P.M. DINING: Twenty Five Beautiful Wahines to serve you
Delicious Food in Charming surroundings.

7:45 P.M. ENTERTAINMENT: The Minehune Troupe of Polynesian
to Dancers performing Island Dances to the tune of
9:00 P.M. Hawaiian guitars. See the facinating FIRE DANCE.
Listen to the beautiful songs.

TICKETS: Admission is by ticket only. Due to limited space
the tickets are restricted to only 600 active members
of Town Hall Center and their House Guests. First come
First Served (Tickets).

Get your tickets from any Town Crier Club Member (see list)
or from the Chairment of all Town Hall Clubs.

CONTRIBUTION \$2.00 per Person.

WEAR YOUR MUMU, LAVA LAVA, HAWAIIAN SHIRT.

LETS MAKE A DATE FOR OCTOBER 18th, HAWAIIAN LUAU.

Margaret Cook, Luau Chairman
11409 109th Ave
933-3739

Art Mathis, Ticket Chairman
10151 Sun City Blvd.
933-3150

May 3, 1965

Leland D. Cornell
President
A. Lambert Bergman
Vice President

Bertha A. Roberts
Treasurer
John E. Davis
Secretary



Sun City
ARIZONA

Phone 933-5281

Zip Code 85351

Town Hall Center

10600 Peoria Ave.

May 3, 1965

TO: Leo Yort
Helen Foster
Bertha Roberts
Lambert Bergman ✓
Leland Cornell
Landon Atkins

SCHEDULE OF RENTAL RATES, TOWN HALL AREA

<u>SPACE</u>	<u>A. M.</u>	<u>P.M.</u>	<u>EVENING</u>
Auditorium	\$20.00	\$35.00	\$75.00
Administration, Lounge	10.00	15.00	25.00
Clubrooms - 3 units	15.00	25.00	50.00
Clubroom - 1 unit	5.00	9.00	17.00
Kitchen Use - extra	10.00	10.00	10.00
Patio	5.00	5.00	10.00

House Committee Approved 4/24/65

Board of Directors Approved 5/3/65

*Above are Minimums.
Renter pays 15% of Gross or Minimum
whichever ever is the greater*

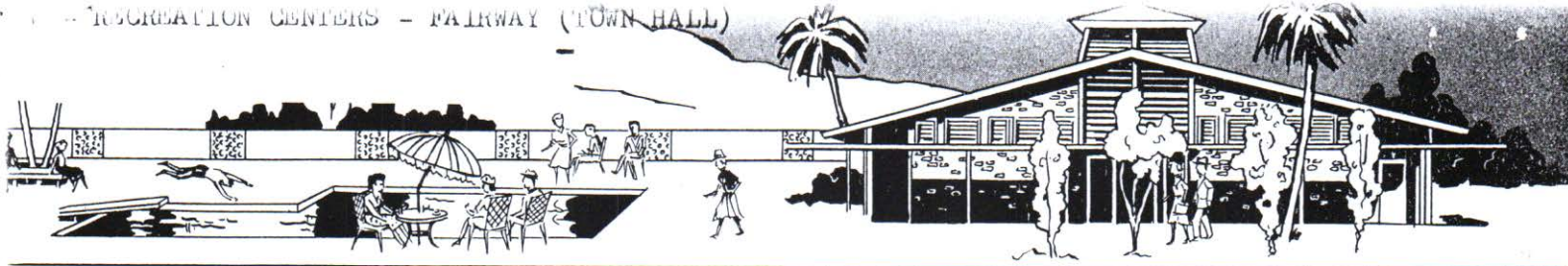

TOWN HALL RECREATIONAL ACTIVITIES CENTER

10600 PEDRIA AVENUE

DEL WEBB'S
Sun City
ARIZONA

3/65

On December 31, 1964, all resident members of the Town Hall area were notified by letter that the membership dues for Town Hall were \$20.00 per member per year, payable January 1st.

As of March 1st there were a small number who had failed to claim their 1965 membership cards. In as much as we have had no response to the several notices which were mailed to these members, your Board of Directors on March 15, 1965, passed the attached resolution. Briefly, this resolution means; that delinquent members names shall be posted on the Town Hall bulletin board on April 1, 1965.

We hope that the non-payment of your membership dues are purely an oversight and that it will not be necessary to include your name on the delinquent list. Your 1965 card is available in the office in Town Hall Lounge.

We sincerely regret the necessity of this letter as we believe you have overlooked the fact that the value of your property is greatly enhanced by your membership in the Town Hall Club.

Sincerely,

Leland D. Cornell, President.
TOWN HALL CENTER

RESOLUTION

RESOLUTION REGARDING UNPAID MEMBERSHIP DUES.

Authorized by the Board of Directors on March 15th meeting.

- Whereas - When each purchaser bought a home from the Del E. Webb Development Company in the Valley of the Sun, here in Sun City, the purchase included his proportionate share of Sun City privileges, all of the facilities - swimming pool, shuffleboard courts, lawn bowling, putting greens, Town Hall facilities, Art and Craft Center and Agricultural Center;
- Whereas - Each purchaser of a home in Town Hall Center area signed a Community Facilities Agreement in which he assumed responsibility for his proportionate share of the operation and maintenance expenses of Town Hall Facilities;
- Whereas - At a regular meeting of Sun City Town Hall Center, the members voted to accept from Del E. Webb Development Company the complete ownership, operation and maintenance of Town Hall Center including grounds and all facilities;
- Whereas - On January 1st, 1965, and thereafter, all expenses connected with the operation and maintenance of Town Hall Center became the financial and management responsibility of all residents residing in Sun City Town Hall Center area;

And Whereas - All resident members who have not paid their dues by March 1st of each year shall be considered to be delinquent;

Therefore Be It Resolved - That such delinquent members of Sun City Town Hall area shall be notified, and if their membership dues for the current year are not paid by April 1st, their names shall be posted on an Official Bulletin Board in Sun City Town Hall Center.

*Amended
Sept 7th 1965*

COMMUNITY FACILITIES AGREEMENT

Date _____

I realize and understand that the community recreation facilities located at the northeast corner of Peoria Avenue and 107th Avenue, Sun City, Arizona, are presently owned and controlled by the Del E. Webb Development Co., and are being maintained and operated by that company.

I further understand that at a time when the homes in that vicinity are substantially occupied by home owners such as myself, the Del E. Webb Development Co. will convey, at no cost to me, the entire community facilities to a non-profit corporation formed by the Del E. Webb Development Co. for the benefit of the home owners. I realize that while this transfer will be free to me as a home owner, subsequently the operation and maintenance of the community facilities will be an expense of the non-profit corporation whose members will be the home owners. I agree to pay the assessments deemed necessary by the Board of Directors of the non-profit corporation for the operation and maintenance of the community facilities when the same are transferred. It is understood, however, that the transfer to the non-profit corporation will not be made by the Del E. Webb Development Co. until such time as there are sufficient home owners so that not more than Twenty Dollars (\$20.00) of annual operating costs of the community facilities are attributed to each resident home owner, or if transferred before said time by Webb, Webb agrees to pay the actual operating costs over \$20.00 per resident home owner.

Until the transfer mentioned above has taken place, I agree to pay annually and in advance to the Del E. Webb Development Co., or the non-profit corporation mentioned above, the sum of One Dollar (\$1.00) per month for each resident in the home which I am purchasing until the property is transferred to the non-profit group and different arrangements are made by the governing body of that group. This annual payment shall be on a calendar year basis and the first payment shall cover the period commencing with the home owner's pro-ration date and shall be paid through escrow.

I further agree that in the event of any future sale of my home that the above understanding and agreement will be made a part of the Sales Contract and an obligation of the buyer.

I agree also that my purchase of a home in the Sun City community is subject to my acceptance as a member of the association which will maintain and own the community recreational facilities, such acceptance to be given by the entity in control of those facilities at the time of my purchase.

I agree that in any subsequent sale, assignment or lease of my home by me that, as a condition of such transfer, any purchaser, assignee or lessee of me shall be subject to the same requirement. Any sale, assignment or lease without such written acceptance by the entity controlling the community facilities being deposited in escrow shall be void and of no effect.

Purchaser

Purchaser

Copy



DEED TO TOWN HALL FACILITIES is presented by Tony Kohl (right), Del E. Webb Development Co.'s Sun City project manager, to Town Hall board president Leland Cornell

in ceremony witnessed by Webb officials and Town Hall officers and board members.

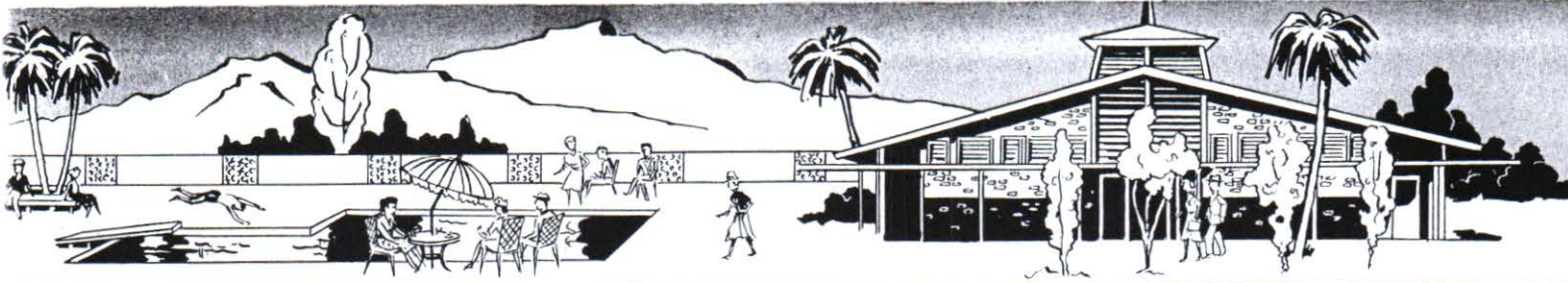

TOWN HALL RECREATIONAL ACTIVITIES CENTER

POST OFFICE BOX 555

DEL WEBB'S
Sun City
 A R I Z O N A

December 31, 1964

TO ALL RESIDENTS OF TOWN HALL AREA:

At the regular November meeting of the Sun City Town Hall Center the members voted to accept from the Del E. Webb Development Company, the complete ownership and operation of Town Hall Center including all facilities. This means that land and improvements estimated to be worth about \$450,000 becomes the property and the responsibility of we the people of Town Hall Center.

As of January 1st, all expenses connected with the maintenance and operation of Town Hall Center shall become the financial and management responsibility of we the people of Town Hall Center.

Considerable discussion has been directed, by your Town Hall Center Board of Directors, to the fact that while some members of Town Hall Center are charged a \$12.00 fee for an activity card, other members must pay \$20.00 for the same privileges. Also since your Board of Directors has no basis upon which to estimate accurately the cost of operation and maintenance to Town Hall facilities, it was decided by your Board that the fee be equalized at \$20.00 per person in order to keep accounts in the black, and provide proper and efficient management.

The Sun City Town Hall Center as it now stands will become the property of the people of Town Hall Center on January 1st, 1965. The additional building and the remodeling of Town Hall granted by the Webb Company will be completed within a few months. The second swimming pool is also to be added to our facilities by the Webb Company.

Your Town Hall Center Board of Directors believe that we the people can be justly proud to own and operate facilities of the calibre we shall have when these additions have been made.

Won't you aid your Board by cheerfully accepting your responsibilities? Whether or not you personally avail yourselves of the many opportunities offered at Town Hall, it still remains an asset to the Community and to your personal property value.

For your information we are attaching a copy of your Community Facilities Agreement. Activity cards are now being issued in the Town Hall Lounge.

Sun City Town Hall Center

Landon B. Atkins Vice Pres.
 Landon B. Atkins

Nov., 1964

VF - RECREATIONAL CENTERS - FAIRWAY (TOWN HALL)



TOWN HALL RECREATIONAL ACTIVITIES CENTER

POST OFFICE BOX 555

DEL WEBB'S
Sun City
A R I Z O N A

November 19, 1964

IMPORTANT NOTICE

To Members of the Sun City Town Hall Center:

At the Nov. 9th meeting of your corporation, we presented the final Proposal of the Del E. Webb Development Corp. regarding turning over the Town Hall Facilities to the Sun City Town Hall Center Corp. This corporation is a non-profit corporation owned by the home owners in the Town Hall area. Briefly this proposal is to build a new building 32 feet by 76 feet, for club facilities, additional parking area space for 100 cars, and another swimming pool when the 3051st residence is sold, plus needed repairs, replacements and redecoration.

This final proposal is based on the facilities serving 3500 residences in Sections 2, 3, 4, 5 and 6.

The members attending the meeting voted approximately two to one for accepting this proposal. (544 for the proposal and 296 against).

The Articles of Incorporation must be changed to add "Section #6" and this requires a vote by the membership. A Special Meeting has been called for 10:00 A.M. Nov. 24, at Town Hall Center and your Board of Directors are respectfully asking that YOU and YOUR NEIGHBORS living in Section 2, 3, 4 and 5 attend this brief meeting to cast your vote.

This is a very important meeting. It will be a short meeting. BE SURE TO BRING YOUR 1964 ACTIVITIES CARD. PASS THIS NOTICE ON TO YOUR NEIGHBORS. MEETING IS NOV. 24 at 10:00 A.M.

Yours truly,
Earl Daniels
Earl Daniels, Secretary.

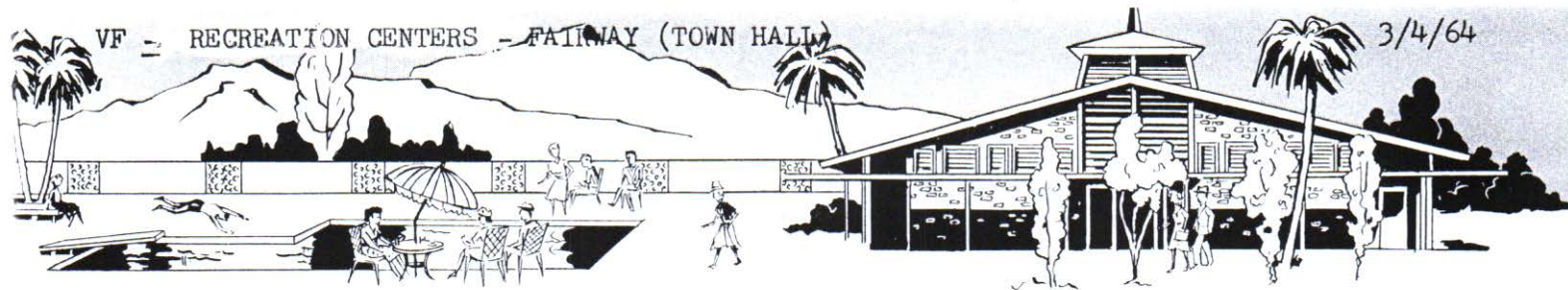

OWN HALL RECREATIONAL ACTIVITIES CENTER

POST OFFICE BOX 555

DEL WEBB'S
Sun City
 A R I Z O N A

March 4, 1964

STATEMENT OF PRINCIPLE FOR TOWN HALL CENTER

The Board of Directors of Town Hall Center in the regular monthly meeting of March 2, 1964, approved the "STATEMENT OF PRINCIPLE" as recommended by the House Committee which follows:

The facilities of Town Hall Center are for the use of all persons holding current Town Hall Center Membership Cards.

Members of Recognized Town Hall Clubs shall not have special advantages over non-club members in the use of Craft Facilities.

For the Safety and Protection of all Town Hall Center members, the Recognized Clubs shall formulate rules and safety regulations covering the use of tools and/or equipment utilized by Club Members and Non-Club Members. (Per By Laws of Sun City Town Hall Center, Article VII, Section 1. paragraph d) All such rules and regulations must be submitted to the CLUB ORGANIZATION COMMITTEE for their approval. Approved rules and regulations must be posted in the area used by the Club.

The facilities in the Arts and Craft Rooms are for hobbies and not for the manufacture of articles to be sold by individuals for private gain.

Recognized Clubs may offer for sale, articles made in the Arts and Craft Rooms provided the profit is retained by the Club.

Recognized Clubs may employ instructors, entertainers, etc., for the benefit of and by the request of its members. Fees, if any, are to be collected by the club.

COPY

(Signed) R. Earl Daniel
 Sec'y Town Hall Center.

RESOLUTION

RESOLUTION REGARDING UNPAID MEMBERSHIP DUES.

Authorized by the Board of Directors on March 15th meeting.

- Whereas - When each purchaser bought a home from the Del E. Webb Development Company in the Valley of the Sun, here in Sun City, the purchase included his proportionate share of Sun City privileges, all of the facilities - swimming pool, shuffleboard courts, lawn bowling, putting greens, Town Hall facilities, Art and Craft Center and Agricultural Center;
- Whereas - Each purchaser of a home in Town Hall Center area signed a Community Facilities Agreement in which he assumed responsibility for his proportionate share of the operation and maintenance expenses of Town Hall Facilities;
- Whereas - At a regular meeting of Sun City Town Hall Center, the members voted to accept from Del E. Webb Development Company the complete ownership, operation and maintenance of Town Hall Center including grounds and all facilities;
- Whereas - On January 1st, 1965, and thereafter, all expenses connected with the operation and maintenance of Town Hall Center became the financial and management responsibility of all residents residing in Sun City Town Hall Center area;
- And Whereas - All resident members who have not paid their dues by March 1st of each year shall be considered to be delinquent;
- Therefore Be It Resolved - That such delinquent members of Sun City Town Hall area shall be notified, and if their membership dues for the current year are not paid by April 1st, their names shall be posted on an Official Bulletin Board in Sun City Town Hall Center.

SUN CITY TOWN HALL CENTER

BY-LAWS

(Adopted September 9, 1963)

(Amended December 8, 1964)

ARTICLE I - NAME

SECTION 1. The name of this non-profit corporation shall be SUN CITY TOWN HALL CENTER.

ARTICLE II - PURPOSES

SECTION 1. The name of this non-profit corporation be identical to those set forth in Article III of the Articles of Incorporation.

ARTICLE III - MEMBERSHIP

SECTION 1. Classification of membership shall be active and associate. Active members shall be home owners, beneficial and/or legal, and/or spouses and other members of the household living in Units 2, 3, 4, 5, or 6, or subsequent beneficial and/or legal owners living within these units who have paid the required assessments.

Associate members shall be renters or lessees of property in Units 2, 3, 4, 5, or 6 and shall have paid the required assessments for their classification.

Membership shall not be transferable.

SECTION 2. Privileges of active members shall be to vote, to hold office, to use all available facilities, subject to the rules and regulations of the recognized clubs, and to participate and become members of all activities and clubs of the Sun City Town Hall Center. They shall have guest privileges as provided by each recognized club.

Privileges of associate members shall be the same as those of active members except to vote or to hold office.

SECTION 3. The assessments shall be determined and collected by the Del E. Webb Company until they formally transfer the properties to this corporation. Thereafter, the assessments for active members for each fiscal year, January 1 through December 31, shall be determined by the Board of Directors of this corporation. Such assessments shall be due and payable prior to January 1 of each year.

If home ownership should be established during the fiscal year, the assessment shall be pro-rated on a monthly basis until the end of the current fiscal year.

Assessments for associate members shall be determined by the Board of Directors on a quarterly, semi-annual or annual basis, payable as of the beginning of their residence.

SECTION 4. Any membership may be suspended by the Board of Directors, after a hearing before the Board, for gross misconduct or violation of the rules or regulations of Sun City Town Hall Center.

SECTION 5. Regular meetings shall be held on the second Monday of the months of January, May, September and November, at 1:30 P.M. at Town Hall, unless otherwise changed by the Board of Directors. One hundred (100) active members may file a request with the Secretary of the Board of Directors for a special meeting, stating the reasons for the meeting. The President shall call such a special meeting within ten (10) days after receiving the request. A quorum for any meeting shall consist of not less than one hundred (100) active members and Roberts' Rules of Order, Revised, shall prevail.

ARTICLE IV - OFFICERS

SECTION 1. The officers of this corporation shall consist of a President, a Vice President, a Secretary, and a Treasurer.

SECTION 2. They shall be elected by secret ballot for the term of one year by the active members of the corporation, according to Article IX, sections 2 and 3.

SECTION 3. Action for removal of any elected officer may be initiated by not less than one hundred (100) bona-fide active members of the corporation, who shall submit their reasons in writing to the Secretary. The request for recall shall be publicized for not less than twenty-six (26) days, after which and within seven (7) days, the members of the corporation may vote on the recall by secret ballot, according to Article IX, section 2 and 3. Two-thirds of all votes cast at the last annual election in December shall be necessary for the recall of an elected officer.

SECTION 4. In case of a vacancy in an elected office, the Board of Directors, subject to the approval of the members, may appoint an active member of the corporation in good standing to serve the unexpired term.

SECTION 5. The duties of the elected officers shall be to:

a. The President

- (1) Preside at all meetings of the corporation and Board of Directors.
- (2) Enforce the By-Laws and Articles of Incorporation.
- (3) Enforce all policies, rules, and regulations as determined by the Board of Directors.
- (4) Call special meetings of the Board of Directors, when necessary.
- (5) Appoint all committees, except the Nominating Committee and the Balloting Committee, with the advice and consent of the Board of Directors.
- (6) Call special meetings of the corporation according to Article III, section 5, or with approval of the Board of Directors.

b. The Vice President

- (1) Assume all the powers and duties of the President, in his absence.

c. The Secretary

- (1) Issue notices of all meetings, keep minutes and necessary records of the corporation and of the Board of Directors.
- (2) Conduct all correspondence relating to the corporation
- (3) Maintain a roster of all members of the Corporation.

d. The Treasurer

- (1) Receive all monies payable to the Corporation.
- (2) Make all disbursements, authorized by the Board of Directors, by check countersigned by the President or such other officers or Board members as may be designated by the Board of Directors.
- (3) Deposit all funds in a bank, designated by the Board of Directors, to the account of Sun City Town Hall Center.

- (4) Report the financial standing of the corporation at all regular Board of Directors and Corporation meetings.
- (5) Submit his financial records on July 1 and January 2 to the Finance Committee for audit.
- (6) a. All officers and board members designated to handle corporation funds shall be bonded.
b. The fiscal year of the corporation shall be January 1 through December 31, of each year.

ARTICLE V - BOARD OF DIRECTORS

SECTION 1. There shall be eleven (11) directors, including the four elected officers, none of whom shall receive a salary for his service to the corporation.

SECTION 2. They shall be elected for the term of one year by the active members of the corporation, according to Article IX, sections 2 and 3.

SECTION 3. They may be removed in the same manner as described in Article IV, section 3.

SECTION 4. A vacancy shall be filled in the same manner as described in Article IV, section 4.

SECTION 5. Regular meetings shall be at Town Hall on the first Monday of each month at 9:00 A.M., unless otherwise specified by the President who shall preside at all meetings. Two-thirds of the members shall constitute a quorum. All meetings shall be conducted in accordance with the By-Laws and Roberts' Rules of Order, Revised.

SECTION 6. The duties of the Board of Directors shall be to:

- a. Govern the proper use of all of the facilities of the corporation including the following:
 - (1) Determination of policies governing the use of all facilities by the recognized clubs and/or other groups.
 - (2) Management of all financial affairs of the corporation.
 - (3) Preservation and control of all physical equipment, including health and safety provisions.
 - (4) Approval and supervision of all necessary committees as provided in Article VI, section 2.
 - (5) Perform all other duties as may be necessary or desirable.
- b. Coordinate the activities of all committees and clubs.
- c. Conduct all elections as provided in Article IX, sections 2 and 3.

ARTICLE VI - COMMITTEES

SECTION 1. Only residents of Sun City Units 2, 3, 4, 5 and 6 holding active membership cards shall be eligible to serve on any committee.

SECTION 2. Standing committees shall be appointed by the President with the advice and consent of the Board of Directors.

SECTION 3. The standing committees and their duties shall be as follows:

- a. COMMITTEE ON COMMITTEES - To recommend qualified persons to the President for committee membership. It shall consist of not less than seven (7) active members.
- b. FINANCE COMMITTEE - To have general control of the finances, subject to the approval of the Board of Directors, including ways and means for obtaining funds nec-

essary to meet the authorized budget for carrying out the work of the corporation.

To present in writing, not later than December 15 of each year, an itemized estimate of the income and expenses for the ensuing year, which upon approval of the Board of Directors shall become the authorized budget for that year, and no obligation beyond the amount thus authorized shall be incurred by any committee or agent of the corporation unless specially authorized by the Board of Directors.

To receive on July 1 and January 2 from the treasurer of the corporation his financial record and not later than July 31 and January 31 audit and report their findings to the Board of Directors who shall have it reported to the members of the corporation at their next regular meeting.

It shall consist of not less than nine (9) active members. The chairman shall attend meetings of the Board of Directors and make such reports as necessary or as requested by the President.

- c. HOUSE COMMITTEE - To have general management, subject to the Board of Directors, of the use of the facilities and equipment of Sun City Town Hall Center and adjoining buildings and grounds, except that which is under direct supervision of recognized clubs.

To receive and consider requests from recognized clubs and/or other groups and organizations within and without Units 2, 3, 4, 5 and 6, who desire to use the facilities and equipment; issue permits according to the rules and regulations governing Sun City Town Hall Center; and make available such facilities and equipment as needed to cover the terms of the permit.

To determine all charges and fees for use of facilities and equipment, collecting same from any group subject to such fees.

To remit promptly to the Treasurer of the corporation all monies received from any source.

To schedule and coordinate all activities and events in which buildings, facilities and equipment of the corporation is involved in and about Sun City Town Hall Center.

To determine, organize, promote and supervise all special entertainment other than that of recognized clubs which will be of interest and benefit to the members of the corporation.

To maintain an inventory and review the use and care of all power and hand tools, equipment facilities, furniture fittings and appliances, and requisition new or replacement materials from the Finance Committee.

To form such sub-committees as properties, scheduling and special entertainment, determining their duties and functions in order to accomplish the purposes and duties of the committee.

To hold regular monthly meetings and assume such duties as may be determined by the Board of Directors.

It shall consist of not less than nine (9) active members, including the Vice-President of the corporation. The Chairman shall attend meetings of the Board of Directors and make such reports as necessary or as requested by the President

- d. SAFETY COMMITTEE - To survey and recommend to the Board of Directors rules and regulations regarding safety precautions and elimination of hazards in the entire Sun City Town Hall Center.

It shall consist of not less than five (5) active members.

- e. **CLUB ORGANIZATION COMMITTEE** - To receive, review and recommend to the Board of Directors applications that conform to Article VII, sections 1 and 2, for new and/or recognized clubs and to assist in their organization and functions.

To review annually all recognized clubs and to report to the Board of Directors any changes in their program, operation and/or By-Laws.

It shall consist of not less than five (5) active members.

- f. **PUBLIC RELATIONS COMMITTEE** - To provide information to all residents of Units 2, 3, 4, 5 and 6 concerning the available facilities, activities and purposes of the corporation, through appropriate publicity.

To maintain good public relations between all residents of Sun City.

It shall consist of not less than five (5) active members plus the publicity chairman of each recognized club.

SECTION 4. Special committees may be appointed by the President with the advice and consent of the Board of Directors.

SECTION 5. All committee members shall declare their availability and willingness to attend the necessary meetings of their respective committee.

SECTION 6. All committee chairmen shall report at least quarterly to the Board of Directors, or when requested by it. They shall attend all corporation meetings and be prepared to make a report, if requested by the President.

ARTICLE VII - RECOGNIZED CLUBS

SECTION 1. A recognized Sun City Town Hall Club is one recommended by the Club Organization Committee and approved by the Board of Directors. The minimum requirements shall be as follows:

- a. It shall have at least 25 members, who shall meet regularly. A list of members shall be made available for inspection upon request of the Club Organization Committee.
- b. It shall have By-Laws approved by the Club Organization Committee, stating its purposes and functions.
- c. It shall be organized with at least three officers: a Chairman, a Vice-Chairman, and a Secretary-Treasurer, all of whom shall be active members of the Sun City Town Hall Center.
- d. Membership shall be open to all assessment paying residents of Units 2, 3, 4, 5 and 6 who may use the equipment and facilities as provided by the club rules and regulations.
- e. Membership shall consist of at least 65% of assessment paying residents of Units 2, 3, 4, 5 and 6, while the remaining membership may consist of residents holding current membership cards from other activity centers of Sun City, provided there is sufficient room for all, as determined by the Club itself.
- f. It shall maintain an inventory, accept and be responsible for tools and equipment under its custody.
- g. All club chairmen shall attend all corporation meetings and be prepared to report, if requested by the President.

SECTION 2. There shall be no conflict between club rules and regulations with the Articles of Incorporation or the By-Laws of the Corporation.

ARTICLE VIII - NOMINATION PROCEDURE

SECTION 1. A nominating committee of nine (9) active members shall make nominations at the November meeting of the Corporation for the eleven directors of the Board, including the four elected officers.

SECTION 2. The nominating committee shall consist only of Sun City Town Hall Center residents to be chosen as follows:

- a. Not later than September 15 of each year, each recognized Sun City Town Hall club shall submit in writing the names of two of its members to the Chairman of the Committee on Committees.
- b. The Committee on Committees shall transmit to the Board of Directors not later than October 1, at least fifteen (15) of the submitted names.
- c. The Board of Directors, at their regular October meeting, shall select nine (9) names from the list submitted to them to serve as the Nominating Committee and shall arrange appropriate announcement of the committee.

SECTION 3. The Nominating Committee shall prepare a slate of not less than two (2) persons for each of the four (4) elected officers, listed alphabetically. They shall also prepare a slate of at least twelve (12) persons, listed alphabetically, for the other seven (7) Directors of the Board. This slate shall be published in the local newspapers and posted on the official bulletin board of the corporation after it is announced at the November meeting.

SECTION 4. Any member of the Nominating Committee, if requested by the committee, may be nominated for any office.

SECTION 5. A person nominated for any office shall declare his availability for attendance at necessary meetings of the office.

SECTION 6. Not less than twenty-six (26) days, nor more than forty (40) days following announcement and publicity of the slate, the Board of Directors shall conduct an election as provided in Article IX, sections 2 and 3.

SECTION 7. Nominations for the eleven directors of the Board, including the four elected officers, may be made from the floor at the November meeting of the Corporation.

SECTION 8. There shall be no members ex-officio on the Nominating Committee.

ARTICLE IX - VOTING PROCEDURE

SECTION 1. A voice or standing vote shall prevail on all matters of business except as follows:

- a. The election of all officers and directors.
- b. Amendments to the By-Laws.
- c. Recall of any officer and/or any member of the Board of Directors.
- d. When a majority of the Board of Directors request a secret ballot.
- e. When a secret ballot is requested by a majority vote of the eligible members of the corporation at a regular meeting.
 - (1) The question or questions to be voted on shall be open for discussion in at least one Corporation meeting and publicized for not less than twenty-six (26) days nor more than forty (40) days prior to the date designated for voting.

(2) Voting date shall be decided by the Board of Directors.

SECTION 2. Procedure for voting by secret ballot shall be as follows:

- a. Voting shall proceed under supervision of the Balloting Committee composed of five (5) members of the Board of Directors appointed by the Board. Ballot boxes and election procedure shall be prepared by this Committee.
- b. Voting shall be in the Sun City Town Hall area and polls shall be open from ten o'clock (10:00) A.M. to seven o'clock (7:00) P.M. on date set for voting.
- c. At least two members of the Balloting Committee shall be in attendance at all times during voting and they shall determine eligibility (Article III, section 1) of all voters, issue all official ballots and witness the casting of the ballot.
- d. Ballot boxes shall remain sealed until polls are closed, then opened and votes tabulated in the presence of at least three (3) members of the Balloting Committee.
- e. Any recognized club of Sun City Town Hall Center may designate one watcher to be present at the tabulation of the votes.
- f. The person receiving the highest number of votes for each office shall be declared elected by the Chairman of the Balloting Committee.

SECTION 3. An absentee ballot may be cast as follows.

1. An eligible voter (Article III, section 1) if he will be absent from Maricopa County on the date set for balloting, may cast an absentee ballot at the place and time, or by mail, as designated by the Balloting Committee, but not more than fifteen (15) days nor less than three (3) days prior to the voting date.
2. When requested by an ill or incapacitated eligible voter (Article III, section 1) not more than five (5) days nor

less than two (2) days prior to the voting date, any two members of the Balloting Committee shall take an official ballot and a sealed ballot box to his home and witness the casting of his absentee ballot.

- c. Ballot boxes containing absentee votes shall be opened and the ballots tabulated at the same time and place and under the same conditions as the regular ballots.

SECTION 4. The newly elected officers and members of the Board of Directors shall take office at the regular January meeting of the Corporation.

ARTICLE X - AMENDMENTS

SECTION 1. Action on changes and/or amendments to the By-Laws may be initiated by the Board of Directors or by petition of at least one hundred (100) active members of the Corporation. In either case such proposed changes and/or amendments shall be given to the Secretary of the Board of Directors at least ten (10) days prior to a regularly scheduled meeting of the corporation at which meeting the proposed changes and/or amendments shall be read. Immediately following such public reading, the Secretary shall post a facsimile of the proposed changes and/or amendments on the official bulletin board of the corporation and provide for its publication in the local newspapers. Such proposed changes and $\frac{1}{8}$ or amendments shall be publicized for not less than twenty-six (26) days, nor more than forty (40) days prior to voting on them.

SECTION 2. Voting shall be according to Article IV, section 2 and 3. A two-thirds vote of all votes cast at the last annual election in December shall be required to change or amend the By-Laws.

ARTICLE XI - RESTRICTION

SECTION 1. No article in these By-Laws shall be in conflict with the Articles of Incorporation.

SUN CITY TOWN HALL CENTER, INC.**BY-LAWS**

(Adopted September 9, 1963)

ARTICLE I - NAME

SECTION 1. The name of this non-profit corporation shall be SUN CITY TOWN HALL CENTER.

ARTICLE II - PURPOSES

SECTION 1. The purposes of this corporation shall be identical to those set forth in Article III of the Articles of Incorporation.

ARTICLE III - MEMBERSHIP

SECTION 1. Classifications of membership shall be active and associate. Active members shall be home owners, beneficial and/or legal, and/or spouses and other members of the household living in sections 2, 3, 4, or 5, or subsequent beneficial and/or legal owners living within these sections who have paid the required assessments.

Associate members shall be renters or lessees of property in sections 2, 3, 4 or 5 and shall have paid the required assessments for their classification.

Memberships shall not be transferable.

SECTION 2. Privileges of active members shall be to vote, to hold office, to use all available facilities, subject to the rules and regulations of the recognized clubs, and to participate and become members of all activities and clubs of the Sun City Town Hall Center. They shall have guest privileges as provided by each recognized club.

Privileges of associate members shall be the same as those of active members except to vote or to hold office.

SECTION 3. The assessments shall be determined and collected by the Del E. Webb Company until they formally transfer the properties to this corporation. Thereafter, the assessments for active members for each fiscal year, January 1 through December 31, shall be determined by the Board of Directors of this corporation. Such assessments shall be due and payable prior to January 1 of each year.

If home ownership should be established during the fiscal year, the assessment shall be pro-rated on a monthly basis until the end of the current fiscal year.

Assessments for associate members shall be determined by the Board of Directors on a quarterly, semi-annual or annual basis, payable as of the beginning of their residence.

SECTION 4. Any membership may be suspended by the Board of Directors, after a hearing before the Board, for gross misconduct or violation of the rules or regulations of Sun City Town Hall Center.

SECTION 5. Regular meetings shall be held on the second Monday of the months of January, May, September and November, at 1:30 P.M. at Town Hall, unless otherwise changed by the Board of Directors. One hundred (100) active members may file a request with the Secretary of the Board of Directors for a special meeting, stating the reasons for the meeting. The President shall call such a special meeting within ten (10) days after receiving the request. A quorum for any meeting shall consist of not less than one hundred (100) active members and Roberts' Rules of Order, Revised, shall prevail.

ARTICLE IV - OFFICERS

SECTION 1. The officers of this corporation shall consist of a President, a Vice President, a Secretary, and a Treasurer.

SECTION 2. They shall be elected by secret ballot for the term of one year by the active members of the corporation, according to Article IX, sections 2 and 3.

SECTION 3. Action for removal of any elected officer may be initiated by not less than one hundred (100) bonafide active members of the corporation, who shall submit their reasons in writing to the Secretary. The request for recall shall be publicized for not less than twenty-six (26) days, after which and within seven (7) days, the members of the corporation may vote on the recall by secret ballot, according to Article IX, section 2 and 3. Two-thirds of all votes cast at the last annual election in December shall be necessary for the recall of an elected officer.

SECTION 4. In case of a vacancy in an elected office, the Board of Directors, subject to the approval of the members, may appoint an active member of the corporation in good standing to serve the unexpired term.

SECTION 5. The duties of the elected officers shall be to:

- a. The President
 - (1) Preside at all meetings of the corporation and Board of Directors.
 - (2) Enforce the By-Laws and Articles of Incorporation.
 - (3) Enforce all policies, rules, and regulations as determined by the Board of Directors.
 - (4) Call special meetings of the Board of Directors, when necessary.
 - (5) Appoint all committees, except the Nominating Committee and the Balloting Committee, with the advice and consent of the Board of Directors.
 - (6) Call special meetings of the corporation according to Article III, section 5, or with approval of the Board of Directors.
- b. The Vice President
 - (1) Assume all the powers and duties of the President, in his absence.
- c. The Secretary
 - (1) Issue notices of all meetings, keep minutes and necessary records of the corporation and of the Board of Directors.
 - (2) Conduct all correspondence relating to the corporation.
 - (3) Maintain a roster of all members of the Corporation.
- d. The Treasurer
 - (1) Receive all monies payable to the corporation.
 - (2) Make all disbursements, authorized by the Board of Directors, by check countersigned by the President or such other officers or Board members as may be designated by the Board of Directors.
 - (3) Deposit all funds in a bank, designated by the Board of Directors, to the account of Sun City Town Hall Center.

- (4) Report the financial standing of the corporation at all regular Board of Directors' and Corporation meetings.
- (5) Submit his financial records on July 1 and January 2 to the Finance Committee for audit.
- (6) He shall be bonded.
- (7) The fiscal year of the corporation shall be January 1 through December 31 of each year.

ARTICLE V - BOARD OF DIRECTORS

SECTION 1. There shall be eleven (11) directors, including the four elected officers, none of whom shall receive a salary for his service to the corporation.

SECTION 2. They shall be elected for the term of one year by the active members of the corporation, according to Article IX, sections 2 and 3.

SECTION 3. They may be removed in the same manner as described in Article IV, section 3.

SECTION 4. A vacancy shall be filled in the same manner as described in Article IV, section 4.

SECTION 5. Regular meetings shall be at Town Hall on the first Monday of each month at 9:00 A.M., unless otherwise specified by the President who shall preside at all meetings. Two-thirds of the members shall constitute a quorum. All meetings shall be conducted in accordance with the By-Laws and Roberts' Rules of Order, Revised.

SECTION 6. The duties of the Board of Directors shall be to:

- a. Govern the proper use of all of the facilities of the corporation including the following:
 - (1) Determination of policies governing the use of all facilities by the recognized clubs and/or other groups.
 - (2) Management of all financial affairs of the corporation.
 - (3) Preservation and control of all physical equipment, including health and safety provisions.
 - (4) Approval and supervision of all necessary committees as provided in Article VI, section 2.
 - (5) Perform all other duties as may be necessary or desirable.
- b. Coordinate the activities of all committees and clubs.
- c. Conduct all elections as provided in Article IX, sections 2 and 3.

ARTICLE VI - COMMITTEES

SECTION 1. All residents of Sun City sections 2, 3, 4 and 5 holding active membership cards shall be eligible to serve on any committee.

SECTION 2. Standing committees shall be appointed by the President with the advice and consent of the Board of Directors.

SECTION 3. The standing committees and their duties shall be as follows:

- a. COMMITTEE ON COMMITTEES - To recommend qualified persons to the President for committee membership. It shall consist of not less than seven (7) active members.
- b. FINANCE COMMITTEE - To have general control of the finances, subject to the approval of the Board of Directors, including devised ways and means for obtaining funds necessary to meet the authorized budget for carrying out the work of the corporation.

To present in writing, not later than December 15 of each year, an itemized estimate of the income and expenses for the ensuing year, and upon approval of the Board of Directors, it shall become the authorized budget for that year, and no obligations beyond the amount thus authorized shall be incurred by any committee or agent of the corporation unless especially authorized by the Board of Directors.

To receive on July 1 and January 2 from the treasurer of the corporation, his financial record and not later than July 31 and January 31, audit and report their findings to the Board of Directors who shall have it reported to the members of the corporation at their next regular meeting.

It shall consist of not less than nine (9) active members. The chairman shall attend meetings of the Board of Directors and make such reports as necessary, or as requested by the President.

- c. HOUSE COMMITTEE - To have general management, subject to the Board of Directors, of the use of the facilities and equipment of Sun City Town Hall Center and adjoining buildings and grounds, except that which is under direct supervision of recognized clubs.

To receive and consider requests from recognized clubs and/or other groups and organizations within and without Sections 2, 3, 4 and 5, who desire to use the facilities and equipment; issue permits according to the rules and regulations governing Sun City Town Hall Center; and make available such facilities and equipment as needed to cover the terms of the permit.

To determine all charges and fees for use of facilities and equipment, collecting same from any group subject to such fees.

To remit promptly to the Treasurer of the corporation all monies received from any source.

To schedule and coordinate all activities and events in which buildings, facilities and equipment of the corporation is involved in and about Sun City Town Hall Center.

To determine, organize, promote and supervise all special entertainment other than that of recognized clubs which will be of interest and benefit to the members of the corporation.

To maintain an inventory and review the use and care of all power and hand tools, equipment facilities, furniture, fittings and appliances, and requisition new or replacement materials from the Finance Committee.

To form such sub-committees as properties, scheduling and special entertainment, determining their duties and functions in order to accomplish the purposes and duties of the committee.

To hold regular monthly meetings and assume such duties as may be determined by the Board of Directors.

It shall consist of not less than nine (9) active members, including the Vice-President of the corporation. The Chairman shall attend meetings of the Board of Directors and make such reports as necessary or as requested by the President.

- d. SAFETY COMMITTEE - To survey and recommend to the Board of Directors, rules and regulations regarding safety precautions and elimination of hazards in the entire Sun City Town Hall Center.

It shall consist of not less than five (5) active members.

- e. CLUB ORGANIZATION COMMITTEE - To receive, review and recommend to the Board of Directors, applications that conform to Article VII, sections 1 and 2, for new and/or recognized clubs and to assist in their organization and functions.

To review annually all recognized clubs and to report to the Board of Directors any changes in their program,

operation and/or By-Laws.

It shall consist of not less than five (5) active members.

- f. **PUBLIC RELATIONS COMMITTEE** - To provide information to all residents of Sections 2, 3, 4 and 5 concerning the available facilities, activities and purposes of the corporation, through appropriate publicity.

To maintain good public relations between all residents of Sun City.

It shall consist of not less than five (5) active members plus the publicity chairman of each recognized club.

SECTION 4. Special committees may be appointed by the President with the advice and consent of the Board of Directors.

SECTION 5. All committee members shall declare their availability and willingness to attend the necessary meetings of their respective committee.

SECTION 6. All committee chairmen shall report at least quarterly to the Board of Directors, or when requested by it. They shall attend all corporation meetings and be prepared to make a report, if requested by the President.

ARTICLE VII - RECOGNIZED CLUBS

SECTION 1. A recognized Sun City Town Hall Club is one recommended by the Club Organization Committee and approved by the Board of Directors. The minimum requirements shall be as follows:

- a. It shall have at least 25 members, who shall meet regularly.
- b. It shall have By-Laws approved by the Club Organization Committee, stating its purposes and functions.
- c. It shall be organized with at least three officers: a Chairman, a Vice-Chairman, and a Secretary-Treasurer.
- d. Membership shall be open to all assessment paying residents of Sections 2, 3, 4 and 5 who may use the equipment and facilities as provided by the club rules and regulations.
- e. Membership may consist of at least 65% of assessment paying residents of Sections 2, 3, 4 and 5, while the remaining membership may consist of residents holding current membership cards from other activity centers of Sun City, provided there is sufficient room for all, as determined by the Club itself.
- f. It shall maintain an inventory, accept and be responsible for tools and equipment under its custody.
- g. All club chairmen shall attend all corporation meetings and be prepared to report, if requested by the President.

SECTION 2. There shall be no conflict between club rules and regulations, the Articles of Incorporation, and the By-Laws of the Corporation.

ARTICLE VIII - NOMINATION PROCEDURE

SECTION 1. A nominating committee of nine (9) active members shall make nominations at the November meeting of the Corporation for the eleven directors of the Board, including the four elected officers.

SECTION 2. The nominating committee shall be chosen as follows:

- a. Not later than September 15 of each year, each recognized Sun City Town Hall club shall submit in writing the names of two of its members to the chairman of the Committee on Committees.
- b. The Committee on Committees shall transmit to the Board of Directors not later than October 1, at least fifteen (15) of the submitted names.

- c. The Board of Directors, at their regular October meeting, shall select nine (9) names from the list submitted to them to serve as the Nominating Committee and shall arrange appropriate announcement of the committee.

SECTION 3. The Nominating Committee shall prepare a slate of not less than two (2) persons for each of the four (4) elected officers, listed alphabetically. They shall also prepare a slate of at least twelve (12) persons, listed alphabetically, for the other seven (7) Directors of the Board. This slate shall be published in the local newspapers and posted on the official bulletin board of the corporation after it is announced at the November meeting.

SECTION 4. Any member of the Nominating Committee, if requested by the committee, may be nominated for any office.

SECTION 5. A person nominated for any office shall declare his availability for attendance at necessary meetings of the office.

SECTION 6. Not less than twenty-six (26) days, nor more than forty (40) days following announcement and publicity of the slate, the Board of Directors shall conduct an election as provided in Article IX, sections 2 and 3.

SECTION 7. Nominations for the eleven directors of the Board, including the four elected officers, may be made from the floor at the November meeting of the Corporation.

SECTION 8. There shall be no members ex-officiis on the Nominating Committee.

ARTICLE IX - VOTING PROCEDURE

SECTION 1. A voice or standing vote shall prevail on all matters of business except as follows:

- a. The election of all officers and directors.
 - b. Amendments to the By-Laws.
 - c. Recall of any officer and/or any member of the Board of Directors.
 - d. When a majority of the Board of Directors request a secret ballot.
 - e. When a secret ballot is requested by a majority vote of the eligible members of the corporation at a regular meeting.
- (1) The question or questions to be voted on shall be open for discussion in at least one Corporation meeting and publicized for not less than twenty-six (26) days nor more than forty (40) days prior to the date designated for voting.
 - (2) Voting date shall be decided by the Board of Directors.

SECTION 2. Procedure for voting by secret ballot shall be as follows:

- a. Voting shall proceed under supervision of the Balloting Committee composed of five (5) members of the Board of Directors appointed by the Board. Ballots, ballot boxes and election procedure shall be prepared by this Committee.
- b. Voting shall be in the Sun City Town Hall area and polls shall be open from ten o'clock (10:00) A.M. to seven o'clock (7:00) P.M. on date set for voting.
- c. At least two members of the Balloting Committee shall be in attendance at all times during voting and they shall determine eligibility (Article III, section 1) of all voters, issue all official ballots and witness the casting of the ballot.
- d. Ballot boxes shall remain sealed until polls are closed, then opened and votes tabulated in the presence of at least three (3) members of the Balloting Committee.

- e. Any recognized club of Sun City Town Hall Center may designate one watcher to be present at the tabulation of the votes.
- f. The person receiving the highest number of votes for each office shall be declared elected by the Chairman of the Balloting Committee.

SECTION 3. An absentee ballot may be cast as follows:

- a. An eligible voter (Article III, section 1) if he will be absent from Maricopa County on the date set for balloting, may cast an absentee ballot at the place and time, or by mail, as designated by the Balloting Committee, but not more than fifteen (15) days nor less than three (3) days prior to the voting date.
- b. When requested by an ill or incapacitated eligible voter (Article III, section 1) not more than five (5) days nor less than two (2) days prior to the voting date, any two members of the Balloting Committee shall take an official ballot and a sealed ballot box to his home and witness the casting of his absentee ballot.
- c. Ballot boxes containing absentee votes shall be opened and the ballots tabulated at the same time and place and under the same conditions as the regular ballots.

SECTION 4. The newly elected officers and members of

the Board of Directors shall take office at the regular January meeting of the Corporation.

ARTICLE X - AMENDMENTS

SECTION 1. Action on changes and/or amendments to the By-Laws may be initiated by petition of at least one hundred (100) active members of the Corporation. It shall be given to the Secretary of the Board of Directors at least ten (10) days prior to a regularly scheduled meeting of the corporation at which meeting the petition proposing changes and/or amendments shall be read. Immediately following such public reading, the Secretary shall post a facsimile of the petition on the official bulletin board of the corporation and provide for its publication in the local newspapers. Such petition shall be publicized for not less than twenty-six (26) days, nor more than forty (40) days prior to voting on it.

SECTION 2. Voting shall be according to Article IX, sections 2 and 3. A two-thirds vote of all votes cast at the last annual election in December shall be required to change or amend the By-Laws.

ARTICLE XI - RESTRICTION

SECTION 1. No article in these By-Laws shall be in conflict with the Articles of Incorporation.

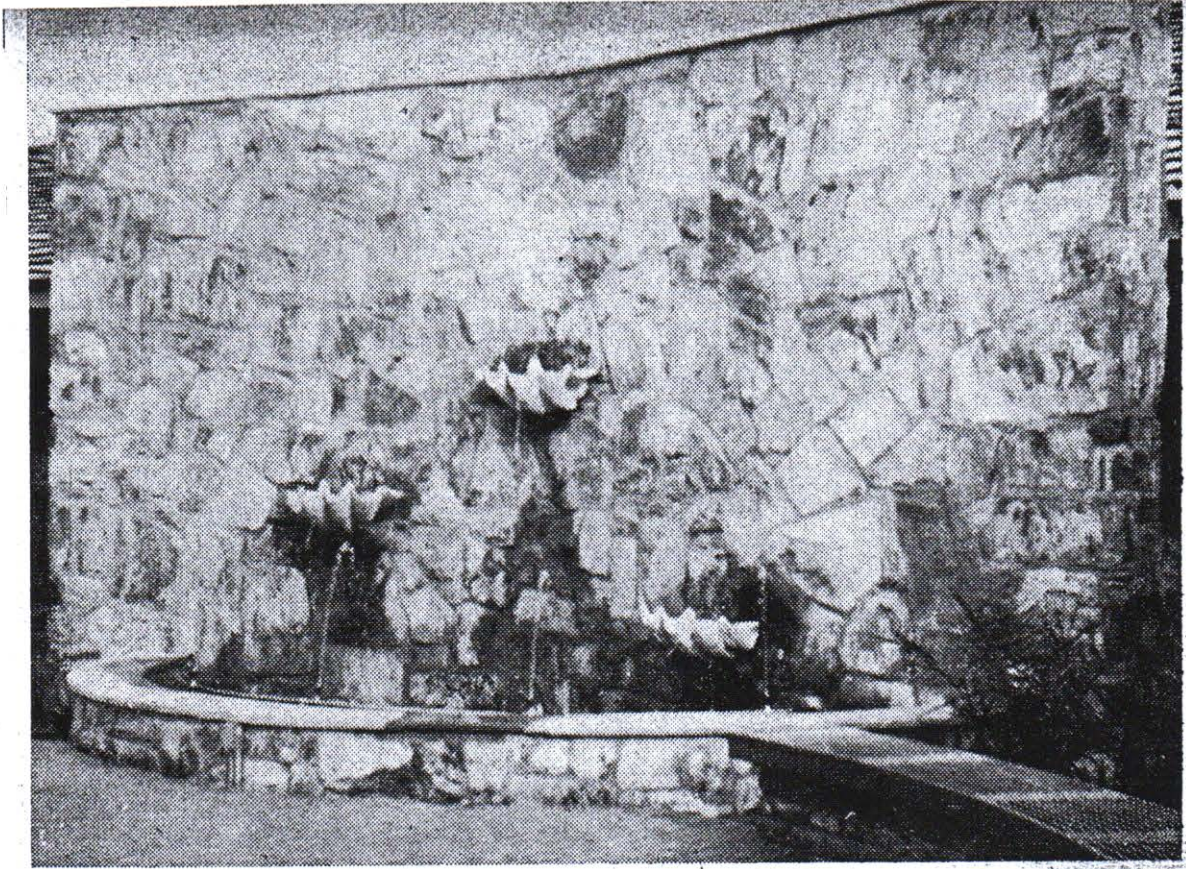

(NEWS-SUN STAFF PHOTO)

DRAMATIC HIGHLIGHT of Town Hall patio in new Sun City recreation area is this fountain and pool, with waterfall effect created by three giant seashells. New area will open officially Sunday, with special entertainment program starting at 2 p.m.

Sun Citians Accept Recreation Facility

By a vote of 1,051 to 54, members of the Sun City civic association expressed their overwhelming approval of the proposal to accept the area recreation facilities from the Del E. Webb Development Co.

The crowd which turned out last Thursday long before voting began was so large that the open meeting held prior to the casting of votes had to be moved out of the Community Center into the patio. Even so, the throng overflowed the seats and extended from the Webb offices to the swimming pool.

ACTING SWIFTLY subsequent to the approval, the association board met Friday with members of the Webb organization and signed the documents completing the transfer. Immediately thereafter the articles incorporating the association were sent into Phoenix for filing and the board met in special session to establish a corporation to take title to the properties.

By unanimous vote, the officers of the association, Ralph Hawley, president; Lynn Olsen, vice president; and Leo B. Wilson, secretary-treasurer, were

elected to identical positions in the corporation.

SPEAKERS OF the vote on the recreation facilities transfer, Hawley said that he and the board were naturally highly gratified at the overwhelmingly favorable outcome, as they considered it to be an expression of confidence in the board's efforts and a desire to retain the facilities for the exclusive use of Sun City residents.

After election of officers, the board took up the question of by-laws. The amount of the membership dues that will have to be charged was left in abeyance until a report can be received from a special finance committee composed of six men not now on the board.

THEY ARE Wright Paterson, 10717 Cherry Hills Dr., Stewart Greisen, 12041 Hacienda Dr., Stephen Wirtz, 12006 Pebble Beach, Clarence Dilfill, 12202 105th Ave., Steve Quayle, 10614 Riviera Dr., and Arthur Reed, 11610 Desert Hills Dr.

These men have all had long experience qualifying them to handle their task. Paterson was a director for Northern States Power Co.; Greisen was an executive for McCrory Stores; Wirtz was an Omaha bank executive for 40 years; Dilfill was operating vice president of a railway; Quayle was mining superintendent for M. A. Hanna Co., and Reed was an accounting division executive for Union Oil Co.



CENTER OPEN FOR SUN CITY NO. 2

Luxuriously landscaped \$350,000 recreational and community center is the core of a new \$25 million development of homes and apartments for senior citizens which the Del E. Webb Corp. will open tomorrow at Sun City northwest of Phoenix.

Webb Gives Clubroom To Sun City

Special to The Gazette

SUN CITY—The \$250,000 recreation center and community hall built by the Del E. Webb Corp. here was turned over as a gift this week to the residents of the retirement community.



HAWLEY

A retired Yale professor, Ralph Hawley, president of the Sun City Civic Association, accepted the gift from Tom Breen, head of the Webb housing division.

Facilities included in the gift, promised to the residents by Webb when the community was begun, are a swimming pool, community hall which will seat 150, stage and dressing rooms, clubrooms, arts and crafts building, shuffleboard courts, all on 1.5 acres of land.

The turnover signified the completion of Webb's "first" Sun City. The announcement of the start of a second development adjacent and identical to the first came today.

Sun City is the subject of a feature in the January issue of the Rockwell Water Journal, published monthly at Pittsburgh, Pa., by the Rockwell Manufacturing Co.

Second Sun City's Recreation Center, Homes To Be Displayed

By JIM WERNER
Gazette Real Estate Editor

A second Sun City retirement community larger than the first—a \$25 million project—has been started northwest of Phoenix.

The Del. E. Webb Corp. will open a completed recreation center to serve the new community, and model homes, tomorrow.

The development, the second phase of the retirement city being developed by Webb on 30,000 acres northwest of Peoria, will adjoin the first Sun City project, and will become a part of the overall development.

IT WILL HAVE its own recreation center, a \$350,000 project already completed, as well as 2,000 homes and eventually its own commercial center.

The first nine holes of a second 18-hole Sun City golf course also are currently under construction to serve homes in the development's second section.

The development will center around the community center and recreational facilities located at 107th Avenue about a mile south of U.S. Highway 60-70-89.

The center includes a town hall auditorium with stage, dressing rooms and kitchen facilities, a sound system and furnishings, a swimming pool with cabana and sun terraces, a sewing room, art room, photographic lab, ceramics room, basket room, wood-working and lapidary shops, leather work room, and jewelry, enameling, and modeling rooms.

ALL ARE ALREADY furnished and equipped for use by the first residents to occupy homes in the new section.

Outside the community hall is

a large Greek theater-like patio area for year-round outdoor events.

New homes will include three expanded versions of earlier models. Tom Breen, head of the Del E. Webb Development Co., said the firm has learned that many of the senior citizens want larger homes, and a number will be offered.

One new design will offer two bedrooms, two baths, and a leisure room. Another will have three bedrooms, two baths, and a leisure room. Prices will range from \$9,150 to \$14,550.

NOW NEARING completion at Sun City are the last of 1,600 homes in the first section and 200 co-operative apartments, representing \$17 million in improvements.

The new development calls for

1,975 single-family homes and 400 cooperative apartments, some in two-story structures.

The HiwayHouse at Sun City is being expanded by an additional 36 rooms and a swimming pool, and the commercial center is being doubled in size. Several new stores are to open in mid-February.

N.D.

SUN CITY TOWN HALL CENTER FACILITIES AGREEMENT

For and in further consideration of the Warranty Deed to me made and to be delivered for the property described as Lot _____

and located at _____ Sun City, Arizona, I enter into this Facilities Agreement with Sun City Town Hall Center, a nonprofit corporation, which owns and operates the Town Hall recreation facilities located at the northeast corner of Peoria Avenue and 107th Avenue, Sun City, Airzona.

I understand that the operation and maintenance of the Town Hall facilities are obligations of Sun City Town Hall Center whose members are the home owners and for whose benefit the said facilities are operated and maintained.

I further understand that the said facilities enhance the value of my property, that they were an inducement to me and other home owners to purchase our homes and also added to the prestige of this retirement center in all parts of the United States and the Americas.

I agree to pay annually in advance to Sun City Town Hall Center the amount of the assessments deemed necessary and determined by the Board of Directors for the operation and maintenance of its Town Hall facilities, currently Twenty (\$20.00) Dollars per person. The first payment shall be for a period of one year beginning on the date the home owner closes, said payment to go into escrow to the escrow agent, and said escrow agent shall pay said amount to Sun City Town Hall Center upon closing of the escrow. At the end of the first year I agree to make payment of a prorated assessment to the end of the calendar year and thereafter pay annually in advance for each calendar year.

I further agree that, in the event of sale by me of my home, this agreement shall be transferred and assigned to the purchaser and made a part of the transfer of title, obligating the purchaser to pay all further assessments to become due under the terms of this agreement.

Dated this _____ of _____ 196__

Purchaser

Purchaser

STATE OF ARIZONA)
) SS.
COUNTY OF MARICOPA)

On this _____ day of _____ 196__, before me the undersigned officer, personally appeared _____ and _____, who acknowledged themselves to be the persons who executed the foregoing instrument by signing their names thereto.

In witness whereof, I have hereunto set my hand and official seal.

Notary Public in and for said County and State.

COMMUNITY FACILITIES AGREEMENT

Date _____

I realize and understand that the community recreation facilities located at the northeast corner of Peoria Avenue and 107th Avenue, Sun City, Arizona, are presently owned and controlled by the Del E. Webb Development Co., and are being maintained and operated by that company.

I further understand that at a time when the homes in that vicinity are substantially occupied by home owners such as myself, the Del E. Webb Development Co. will convey, at no cost to me, the entire community facilities to a non-profit corporation formed by the Del E. Webb Development Co. for the benefit of the home owners. I realize that while this transfer will be free to me as a home owner, subsequently the operation and maintenance of the community facilities will be an expense of the non-profit corporation whose members will be the home owners. I agree to pay the assessments deemed necessary by the Board of Directors of the non-profit corporation for the operation and maintenance of the community facilities when the same are transferred. It is understood, however, that the transfer to the non-profit corporation will not be made by the Del E. Webb Development Co. until such time as there are sufficient home owners so that not more than Twenty Dollars (\$20.00) of annual operating costs of the community facilities are attributed to each resident home owner, or if transferred before said time by Webb, Webb agrees to pay the actual operating costs over \$20.00 per resident home owner.

Until the transfer mentioned above has taken place, I agree to pay annually and in advance to the Del E. Webb Development Co., or the non-profit corporation mentioned above, the sum of Twenty Dollars (\$20.00) per year for each resident in the home which I am purchasing until the property is transferred to the non-profit group and different arrangements are made by the governing body of that group. This annual payment shall be on a calendar year basis and the first payment shall cover the period commencing with the home owner's possession and shall be paid through escrow.

I further agree that in the event of any future sale of my home that the above understanding and agreement will be made a part of the Sales Contract and an obligation of the buyer.

I agree also that my purchase of a home in the Sun City community is subject to my acceptance as a member of the association which will maintain and own the community recreational facilities, such acceptance to be given by the entity in control of those facilities at the time of my purchase.

I agree that in any subsequent sale, assignment or lease of my home by me that, as a condition of such transfer, any purchaser, assignee or lessee of me shall be subject to the same requirement. Any sale, assignment or lease without such written acceptance by the entity controlling the community facilities being deposited in escrow shall be void and of no effect.

Purchaser

Purchaser

N.D.

DEL WEBB'S
Sun City
 ARIZONA
TOUR MAP
 of
POINTS OF INTEREST

1. Kings Inn Motor Hotel
2. Activities and Arts & Crafts Center #2
3. Town Hall
4. Information and Sales Office
5. St. Joachim's Catholic Church
6. Shepherd of the Desert Lutheran Church
7. United Church of Sun City (Represents over 40 denominations)
8. St. Christopher's Episcopal Church site
9. United Presbyterian Church site
10. Sun Valley Lodge site (Nursing Home)
11. U.S. Post Office
12. Community Center — Activities and Arts & Crafts Center #1
13. Medical Center
14. Fire Station
15. Shopping Center
- *16. Golf Course Pro Shop (18 hole North Course)
- *17. Golf Course Pro Shop (18 hole South Course)
18. Shopping Center #2 site
19. Office Building

*Two 18 hole Championship Courses
 Putting Greens — Driving Ranges.

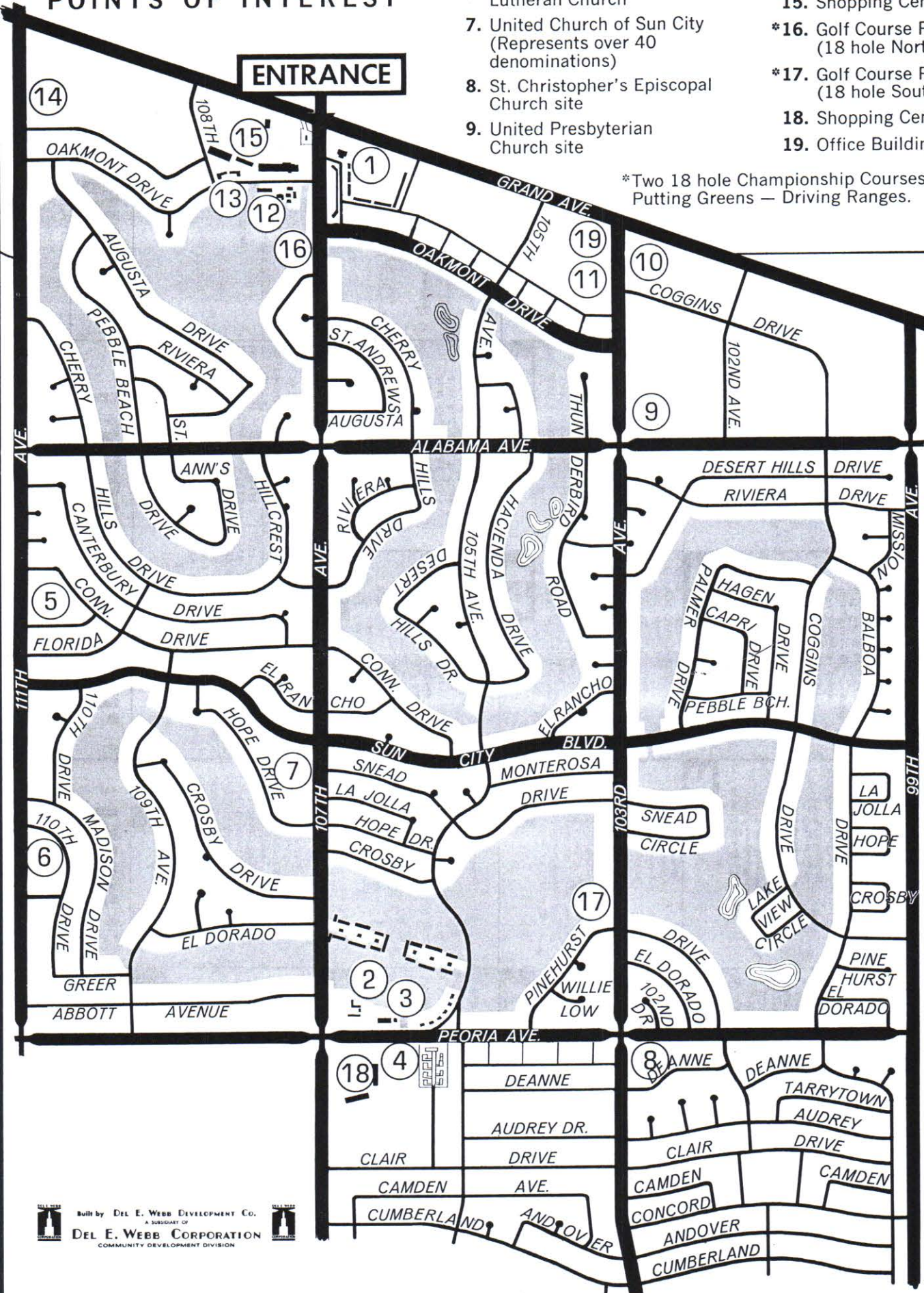

built by DEL E. WEBB DEVELOPMENT CO.
 A SUBSIDIARY OF
DEL E. WEBB CORPORATION
 COMMUNITY DEVELOPMENT DIVISION

WE USUALLY FILL THE BACK PAGE OF THE MONTHLY CALENDAR with info about future Sun Citians, but this month decided to give you a tour map of Sun City. Should friends or relations be planning a visit sometime this year, it might be well to send them one of these maps with your street circled. Extras are available at Kings Inn, Town Hall or at the Sales and Information Office. Happy Easter to you from the Del E. Webb Development Company staff. Expect we'll have a regular Newsletter for you in May.

Jerry Svendsen

Public Relations, P. O. Box 555, Sun City, Arizona

Sun.	Mon.	Tues.	Wed.	Thur.	Fri.	Sat.
	<p>LIBRARY HOURS MONDAY thru FRIDAY 10:00 A. M. - 12:00 Noon Friday - 6:00 P. M. - 8:00 P. M.</p>	<p>CHURCHES IN SUN CITY Catholic - 11625 111th Ave. 8:00-9:30 - 11:00 Christian Science - Community Center - 9:30 Sunday Episcopal - 103rd & Peoria Ave. - 11:00 Sunday Jewish Church - Community Center - 8:00 P. M. Friday Latter Day Saints - Community Center - 5:00 P. M. Sunday Lutheran Church - 11025 111th Ave. 9:00 & 10:30 Sunday Methodist - Town Hall - 11:00 A. M. Sunday Presbyterian Church - Town Hall - 9:30 A. M. / Sunday United Church - 107th & Sun City Blvd. - 9:30 & 11:00 Sunday</p>		<p>1 8:30 Drivers License 9:00 Ceramic Molding 9:30 HOME OWNERS ASSOC. 10:00 Lawn Bowling Instructions 12:45 Ladies Duplicate Bridge 1:00 Leathercraft 1:00 Puppet Club 1:00 Art Class 1:30 Shuffleboard 1:30 Swim Club Meeting 7:30 Bridge Club</p>	<p>2 8:30 Drivers License 9:00 Mosaics 9:00 Trailer Club Meeting 1:00 Ladies Bridge 1:30 Lawn Bowling 1:30 Lapidary Meeting 6:00 Dance Classes 7:00 Sun City Twirlers Square Dance-Beginners 7:00 Mens Club Bridge Tournament 8:30 Sun City Square Dance Intermediates</p>	<p>3 9:30 Gymnastics 11:00 Presbyterian Choir 1:00 Pinochle 8:30 Ballroom Dancing</p>
<p>4 ATTEND THE CHURCH OF YOUR CHOICE 3:00 PRESBYTERIAN MEETING 7:30 WOMENS CHORUS</p>	<p>5 9:00 Ceramics 9:00-4:00 Copper Enameling 10:00 Daughters of the Nile (Sewing) 1:00 Lawn Bowling Meeting 1:30 Lawn Bowling 1:30 Friends of the Library 2:00-4:00 Art Class 7:30 Movies</p>	<p>6 9:00 Sewing Class 9:00 Ceramic Molding 9:00-4:00 Copper Enameling 10:00 Agriculture Club 1:00-4:00 Art Work Shop 1:00 Shuffleboard Meeting 1:30 Shuffleboard 2:30 S. C. & Y. T. Chorus 7:00 Duplicate Bridge 7:30 Goren Bridge Club</p>	<p>7 8:00 Camera Club Field Trip 8:30 Drivers License 9:00 Stitch & Knit 9:00 Art Class 9:00-4:00 Copper Enameling 9:30 Womens Chorus 1:00 Art Class 1:30 Lawn Bowling 2:30 Rhythm Ramblers 4:30 Methodist Choir 7:30 Lenten Service</p>	<p>8 8:30 Drivers License 9:00 Ceramic Molding 10:00 Lawn Bowling Instructions 12:45 Ladies Duplicate Bridge 1:00 Art Class 1:00 Leathercraft 1:00 Puppet Club 1:30 Shuffleboard 7:30 Coin Club 7:30 Bridge Club</p>	<p>9 8:30 Drivers License 9:00 Mosaics 1:00 Ladies Bridge 1:30 Lapidary 1:30 Lawn Bowling 6:00 Dance Classes 7:00 Sun City Twirlers Square Dance-Beginners 7:00 Mens Club Bridge Tournament 8:30 Sun City Twirlers Square Dance-Intermediate</p>	<p>10 9:30 Gymnastics 11:00 Presbyterian Choir 1:00 Pinochle 8:30 Ballroom Dancing</p>
<p>11 ATTEND THE CHURCH OF YOUR CHOICE 2:30 SUN CITY - YOUNGTOWN CHORUS</p>	<p>12 9:00 Ceramics 9:00-4:00 Copper Enameling 10:00-12:00 Help a Neighbors Child 1:30 Lawn Bowling 2:00-4:00 Art Class 7:30 Rock Hound Club 7:30 Movies</p>	<p>13 9:00 Sewing Class 9:00 Ceramic Molding 9:00-4:00 Copper Enameling 12:30 Social & Business for Art Class 1:30 Shuffleboard 3:00 Sr. Womens Golf Assoc. 7:00 Duplicate Bridge 7:30 Goren Bridge Club 7:30 Rose & Garden Society</p>	<p>14 8:30 Drivers License 9:00 Stitch & Knit 9:00 Art Class 9:00-4:00 Copper Enameling 9:30 Womens Chorus 1:00 Art Class 1:30 Lawn Bowling 2:30 Rhythm Ramblers 4:30 Methodist Choir 7:00 Mens Club 7:30 Camera Club</p>	<p>15 8:30 Drivers License 9:00 Ceramic Molding 9:30 Sunshine Board Meeting 10:00 Sunshine Service Meeting 10:00 Lawn Bowling Meeting 10:00 Sr. Women League 12:45 Ladies Duplicate Bridge 1:00 Art Class 1:00 Leathercraft 1:00 Puppet Club 1:30 Shuffleboard 7:30 Bridge Club</p>	<p>16 GOOD FRIDAY 8:30 Drivers License 9:00 Mosaics 1:00 Ladies Bridge 1:30 Lapidary 1:30 Lawn Bowling 6:00 Dance Classes 7:00 Sun City Twirlers Square Dance-Beginners 7:00 Mens Club Bridge Tournament 8:30 Sun City Twirlers Square Dance-Intermediate</p>	<p>17 9:30 Gymnastics 10:00 Woodworking Meeting 11:00 Presbyterian Choir 1:00 Pinochle 8:30 Ballroom Dancing</p>
<p>18 EASTER SUNDAY</p>	<p>19 9:00 Ceramics 9:00-4:00 Copper Enameling 1:30 Lawn Bowling 2:00-4:00 Art Class 7:30 Movies</p>	<p>20 9:00 Sewing Class 9:00 Ceramic Molding 9:00-4:00 Copper Enameling 9:00 Swim Club Breakfast 1:00 Art Work Shop 1:30 Shuffleboard 2:30 Lakeview Coop. 7:00 Duplicate Bridge 7:30 Goren Bridge Club</p>	<p>21 8:30 Drivers License 9:00 Stitch & Knit 9:00 Art Class 9:00-4:00 Copper Enameling 9:30 Womens Chorus 1:00 Art Class 1:30 Lawn Bowling 2:30 Rhythm Ramblers 4:30 Methodist Choir 7:00 Mens Club Program 7:30 Camera Club</p>	<p>22 8:30 Drivers License 9:00 Ceramic Molding 10:00 Lawn Bowling Instructions 12:45 Ladies Duplicate Bridge 1:00 Art Class 1:00 Leathercraft 1:00 Puppet Club 1:30 Shuffleboard 7:30 Coin Club 7:30 Bridge Club</p>	<p>23 8:30 Drivers License 9:00 Mosaics 1:00 Ladies Bridge 1:30 Lapidary 1:30 Lawn Bowling 6:00 Dance Classes 7:00 Sun City Twirlers Square Dance-Beginners 7:00 Mens Club Bridge Tournament 8:30 Sun City Twirlers Square Dance-Intermediate</p>	<p>24 9:30 Gymnastics 11:00 Presbyterian Choir 1:00 Pinochle 8:30 Ballroom Dancing</p>
<p>25 ATTEND THE CHURCH OF YOUR CHOICE 6:00 LUTHERAN CHURCH POT LUCK</p>	<p>26 9:00 Ceramics 9:00-4:00 Copper Enameling 1:30 Lawn Bowling 2:00-4:00 Art Class 7:30 Movies</p>	<p>27 9:00 Sewing Class 9:00 Ceramic Molding 9:00-4:00 Copper Enameling 1:00 Art Work Shop 1:30 Shuffleboard 7:00 Duplicate Bridge 7:30 Goren Bridge Club 7:30 Sun City Players</p>	<p>28 8:30 Drivers License 9:00 Stitch & Knit 9:00 Art Class 9:00-4:00 Copper Enameling 9:30 Womens Chorus 1:00 Art Class 1:30 Lawn Bowling 2:30 Rhythm Ramblers 4:30 Methodist Choir 7:30 Camera Club 7:30 Sun City Players</p>	<p>29 8:30 Drivers License 9:00 Ceramic Molding 10:00 Lawn Bowling Instructions 12:45 Ladies Duplicate Bridge 1:00 Art Class 1:00 Leathercraft 1:00 Puppet Club 1:30 Shuffleboard 7:30 Bridge Club</p>	<p>30 8:30 Drivers License 9:00 Mosaics 1:00 Ladies Bridge 1:30 Lapidary 1:30 Lawn Bowling 6:00 Dance Classes 7:00 Mens Club Bridge Tournament 7:00 Sun City Twirlers Square Dance-Beginners 8:30 Sun City Twirlers Square Dance-Intermediate</p>	

all info

N.D.

TO: THE BOARD OF DIRECTORS AND THE GENERAL MEMBERSHIP
OF TOWN HALL CENTER, PAST, PRESENT AND FUTURE.

OFFICERS

PRESIDENT-LELAND CORNELL * TREASURER-MISS BERTHA ROBERTS
VICE-PRESIDENT-A. LAMBERT BERGMAN * SECRETARY-JOHN E. DAVIS

DIRECTORS

IDA M. ABRISCH
LANDON B. ATKINS
EDWARD C. AUSTIN

ARTHUR CHERRY
DAVIS H. GERIG
EARL M. HOLMES

TAYLOR SMITH

IT IS OUR VERY GREAT PLEASURE TO PRESENT THIS FOLIO CONTAINING THE OFFICIAL DOCUMENTS OF TITLE TRANSFER FOR THE REAL PROPERTY AND IMPROVEMENTS DESCRIBED THEREIN AND IDENTIFIED AS TOWN HALL COMMUNITY CENTER. THIS PARCEL, TOGETHER WITH THE SEVERAL SCORE OF RECREATIONAL FACILITIES ENCOMPASSED WITHIN ITS BOUNDARIES, IS CONVEYED AND ENTRUSTED TO YOUR PERPETUAL STEWARDSHIP. IT IS OUR SINCERE WISH AND PRAYER, THAT THESE FACILITIES WILL CONTINUE TO BE UTILIZED TO THEIR FULLEST EXTENT AS AN INSTRUMENT TO PROMOTE AND FURTHER HUMAN RELATIONS AMONGST FELLOW MEN WHO ARE PRIVILEGED TO SHARE THE REFINED PERIOD OF THEIR LIVES ON A COMMON LEVEL HERE AT SUN CITY.

IT IS INHERENT IN EACH OF US TO DESIRE AND SEEK HAPPINESS FOR OURSELVES AND OUR LOVED ONES. COMPLETE AND TRUE HAPPINESS MUST COME FROM WITHIN. THE SHORTEST ROUTE TO HAPPINESS IS THROUGH THE WARM FRIENDSHIP AND ASSOCIATIONS OF OTHERS TOWARD WHOSE HAPPINESS ONE HAD THE PLEASURE OF CONTRIBUTING PERSONALLY.

MAY GOD GRANT THAT, FROM THIS DAY FORWARD, HAPPINESS IN SUN CITY WILL FLOURISH AND THRIVE FOR ALL THOSE WHO COME AND PARTAKE OF ITS BOUNTY. FUTURE GENERATIONS WILL CARESS AND UPHOLD WITH PRIDE THE TRADITIONS OF TRUE HAPPINESS ESTABLISHED AND CEMENTED HERE BY THE PIONEERS OF THIS NEW WAY OF LIFE.

DEL E. WEBB DEVELOPMENT COMPANY

THE MANAGEMENT



T. P. KOHL
PROJECT MANAGER

STATE OF ARIZONA)
) ss.
COUNTY OF MARICOPA)

On this the _____ day of _____, 196____, before me,
the undersigned officer, personally appeared _____
and _____, who acknowledged themselves to be
the Vice President and _____, respectively, of
DEL E. WEBB DEVELOPMENT CO., an Arizona corporation, and that they,
as such officers being authorized so to do, executed the foregoing instrument
for the purposes therein contained by signing the name of the corporation by
themselves as such officers.

IN WITNESS WHEREOF, I hereunto set my hand and official seal.

Notary Public in and for said County and
State

My Commission Expires:

11. 1/2

A G R E E M E N T

This Agreement made and entered into at Sun City, Maricopa County, Arizona, this _____ day of _____ 1964, by and between DEL E. WEBB DEVELOPMENT CO., an Arizona corporation, hereafter referred to as "Grantor," and SUN CITY TOWN HALL CENTER, an Arizona non-profit corporation, hereafter referred to as "Grantee,"

W I T N E S S E T H

WHEREAS, the Grantor holds legal title to the real property described in the Warranty Deed attached hereto as Exhibit "A" and made a part hereof; and

WHEREAS, there are located on said real property certain improvements, equipment, facilities and appurtenances consisting of a community center, related activities and facilities, including but not limited to lawn bowl area, swimming pool and shuffleboard court, all of which are surrounded by a landscaped area; and

WHEREAS, the Grantor agrees to convey and transfer said property and facilities to the Grantee and the Grantee agrees to accept said property and facilities,

NOW, THEREFORE, in consideration of the mutual covenants and agreements herein contained, the parties agree as follows:

1. The Grantee accepts said property, improvements and facilities and agrees to operate and maintain thereon a community center and recreation facility, without pecuniary gain or profit, for the benefit of the property owners and residents in the area described in said Warranty Deed attached hereto as Exhibit "A."

2. The parties hereto agree that the said property and facilities shall be operated and maintained for the owners and residents of three thousand five hundred (3,500) residential units in Sun City Units two (2), Three (3), four (4), five (5) and six (6).

3. The Grantee agrees to permit the Grantor, its agents and employees to enter into and upon said property and facilities at all reasonable times for the purpose of exhibiting the same and acquainting prospective purchasers with the many advantages and worthwhile activities afforded residents of Sun City Town Hall Center.

4. Grantor agrees that it will provide a perpetual easement from the date hereof for parking facilities in the parking area south of Peoria Avenue and east of 107th Avenue for the parking of one hundred (100) cars or automobiles, approximately opposite the Town Hall, said parking not to be exclusive or separated from the general parking in the proposed shopping center area.

5. The Grantor will secure and furnish title insurance of Twenty-Five Thousand Dollars (\$25,000.00) on said property and facilities, each of the parties hereto to pay one-half of the cost of the said policy.

6. The Grantor agrees to remove the east walls of the men's and ladies' card rooms in the Town Hall, replace them with movable partitions or dividers and install a door for emergency exit in the south wall of Town Hall facing Peoria Avenue.

7. The Grantor agrees to build and construct a building thirty-two feet by seventy-six feet (32' / 76') on the vacant property to the east of the Lounge Building, in keeping with present architecture and construction in accordance with plans and specifications, attached hereto as Exhibit "B." Two (2) sets of movable partitions or dividers shall be installed to make three (3) rooms when in place. Construction on said building to begin within thirty (30) days following the signing of this agreement.

8. The parties agree that they will, concurrently herewith, enter into a letter agreement setting forth a list of things that Grantor agrees to do in order to recondition and properly equip said facilities.

9. The Grantor agrees to construct and place in operation a second swimming pool adjoining the present swimming pool, size, shape, layout and specifications to be in accordance with the plans attached hereto and marked Exhibit "C," said pool to be constructed following the acceptance of the three

thousand fifty-first (3,051st) residential unit by Grantee into its membership.

10. The Grantor will assign and transfer to the Grantee all rights and interest in and to all Community Facilities Agreements with purchasers of residential units made and entered into at the time of transfer of title to home purchasers and owners, both present and future, including resales under the control of the Grantor, pertaining to the area covered by the said Warranty Deed and this agreement. The assignment and transfer of the said Community Facilities Agreements in no way relieves the Grantor of his obligations under the terms of said Agreements.

11. The Grantor agrees to collect for the Grantee the first year's membership fees provided for under the terms of the said Community Facilities Agreements, upon the transfer of title to each purchaser of a residential unit after the date hereof in the area described in said Exhibit "A."

12. The Grantor will pay to the Grantee the unused portion of all Community Facilities Agreement membership fees, on the date the operation and maintenance of Sun City Town Hall property and facilities are turned over to the Grantee.

IN WITNESS WHEREOF, the parties hereto have signed and executed this Agreement the day and year first above written.

DEL E. WEBB DEVELOPMENT CO.,
an Arizona corporation

By _____
Vice President

GRANTOR

SUN CITY TOWN HALL CENTER,
an Arizona non-profit corporation

By _____
President

GRANTEE

WARRANTY DEED

For and in consideration of Ten Dollars (\$10.00), and other good and valuable considerations, DEL E. WEBB DEVELOPMENT CO., an Arizona corporation, herein known as "Grantor," does hereby convey to SUN CITY TOWN HALL CENTER, an Arizona non-profit corporation, herein known as "Grantee," the following described real property situate in Maricopa County, Arizona:

Tract 7 Sun City Unit 3 (Book 92 Page 44 MCR) except the East 107.00 ft. thereof; also that part of Tract E Sun City Unit 3 described as follows: from the Southwesterly corner of said Tract E run thence N 00° 11' E along the West line thereof 21.06 ft.; thence S 71° 30' 30" E parallel to and 20 ft. Northerly at right angles from the South line of said Tract E, 770.98 ft.; thence S 00° 38' 44" E 21.16 ft. to a point on the South line of said Tract E; thence N 71° 30' 30" W along the South line thereof 771.30 ft. to the point of beginning.

Subject to: existing taxes, assessments, liens, encumbrances, covenants, conditions, restrictions, rights-of-way and easements of record.

Further, subject to the following limitation, restriction and condition:

Said property shall be used only for the purposes presently set forth in the Articles of Incorporation of the Grantee herein, i. e., said property shall be used for the purpose of operating and maintaining a community center and recreational facilities, without pecuniary gain or profit, for the benefit of property owners in those retirement communities known as Unit Two (2), Unit Three (3), Unit Four (4), Unit Five (5) and Unit Six (6) of the Subdivision of Sun City, Maricopa County, Arizona.

Grantor warrants title to said property against all persons whomsoever.

Dated the _____ day of _____ 196__.

Attest:

DEL E. WEBB DEVELOPMENT CO.,
an Arizona corporation

By _____
Vice President

VF - RECREATION CENTERS - FAIRWAY (TOWN HALL)
CONSTITUTION

of

TOWN HALL RECREATION ACTIVITIES OF SUN CITY

(Revised October 8, 1962)

Preamble

The Town Hall Recreational Activities Center was de-
signed and built by Del E. Webb Development Co. for the
recreational functions of the residents of Units 2,
3, 4 and 5 of Sun City, Arizona. This center consists of the
Town Hall Building, Swimming Pool, Arts and Crafts, and
other associated areas. The purpose of this Constitution and
By-Laws is to provide administration and coordination of the
various units of activity involved.

ARTICLE 1

Section 1. The name of this organization shall be The
Town Hall Recreation Activities of Sun City, hereinafter
referred to as Town Hall Center.

ARTICLE 2

Section 1. Membership in Town Hall Center shall consist
of residents of Sun City Units 2, 3, 4 and 5.

ARTICLE 3

Section 1. The Town Hall Center shall be administered
and coordinated by an Activities Board.

Section 2. The Activities Board of Directors shall consist of
seven officers elected at large, and seven directors elected
in accordance with election procedures set forth in the By-laws,
and

Section 3. The recognized clubs are—

- | | |
|----------------------|-----------------------------|
| 1. Art | 8. Lawn Bowling |
| 2. Camera | 9. Mosaic |
| 3. Bridge (Thursday) | 10. Sewing (Stitch & Knit) |
| 4. Bridge (Friday) | 11. Senior League (Women's) |
| 5. Ceramics | 12. Shuffleboard |
| 6. Dancing | 13. Swimming |
| 7. Lapidary | 14. Woodworking |

Section 4. The forming of additional recognized Clubs
shall be governed as provided for in Article 7 of the By-Laws.

ARTICLE 4

Section 1. The officers of the Town Hall Center shall con-
sist of a chairman, a Vice-Chairman, a Secretary, and a
Treasurer.

Section 2. The officers of the Town Hall Center shall be
elected as provided for in Article 8 of the By-Laws.

Section 3. No Club Chairman shall be eligible for any of-
fices enumerated in Section 1 of this Article.

ARTICLE 5

Section 1. Changes and/or amendments to this Constitu-
tion and By-Laws shall be made only by a two-thirds vote
of the Town Hall Center members voting at a called meeting.
Such changes and/or amendments shall be accomplished as
provided for in Article 12 of the By-laws.

ARTICLE 6

Section 1. Any elected officer may be removed from
office for cause by a two-thirds vote of Town Hall Center
members voting at a called meeting. Such action shall be
accomplished as provided for in Article 11 of the By-laws.

BY-LAWS

ARTICLE 1

THE TOWN HALL ACTIVITIES BOARD

Section 1. The Town Hall Activities Board shall hold
regular meetings at least once a month.

Section 2. The duties of the Activities Board shall be to
administer and coordinate the activities of the various Clubs,
use all the facilities in the Town Hall area, and shall
administer the following—

1. Determination of policies governing the use of all facilities.

b. Control and management of financial assets of the Town
Hall Center.

c. Preservation and control of physical equipment.

d. Custody of Club funds turned over to the Board for safe
keeping.

e. Appointment and supervision of Committees.

f. Responsibility for safety provisions.

g. Scheduling and coordinating of all Activities.

h. Supervision of Club organizations.

i. Such other administrative and coordinating duties as may
be necessary.

ARTICLE 2

THE CHAIRMAN

Section 1. It shall be the duty of the Chairman to preside
at all meetings and to direct the activities of the Board.

Section 2. The Chairman shall call special meetings of
the Board when he deems it necessary, or upon request of at
least one-third of the members of the Activities Board.

Section 3. The Chairman shall be responsible for the
appointment of all committees, subject to the advice and
approval of the Activities Board.

ARTICLE 3

THE VICE-CHAIRMAN

Section 1. In the absence of the Chairman, the Vice-
Chairman shall have the powers, prerogatives and duties of
the Chairman.

ARTICLE 4

THE SECRETARY

Section 1. The Secretary shall keep minutes of all meet-
ings.

Section 2. The Secretary shall conduct all correspondence
relating to the Town Hall Center, maintain necessary files,
issue all notices of meetings, and keep a register of members
of the Town Hall Center.

Section 3. The Secretary shall post on the Bulletin Boards
the minutes of all meetings.

ARTICLE 5

THE TREASURER

Section 1. All monies payable to the Town Hall Center
shall be paid to the Treasurer of the Board.

Section 2. All disbursements by the Board shall be made
by checks signed by the Treasurer and countersigned by
the Chairman, or such other member as may be designated
by the Board.

Section 3. The Treasurer shall receive, keep an account
of, and be responsible for all Town Hall Center funds. The
Treasurer shall be bonded when deemed necessary by the
Activities Board.

Section 4. He shall disburse Town Hall Center funds only
on directive of the Activities Board.

Section 5. He shall deposit all Town Hall Center funds
to the account of the Town Hall Recreation Activities of Sun
City in a bank designated by the Board.

Section 6. He shall make a report of the Town Hall Center
financial standing at each meeting of the Board.

Section 7. He shall submit his records on July first and
January second of each year to the Board for audit.

Section 8. He shall post a statement of financial condi-
tions, after approval of the audit by the Board, on the Town
Hall Center bulletin boards.

Section 9. He may receive for deposit and disbursement
monies from the various Clubs as they may direct. Special
accounting shall be made of above funds.

ARTICLE 6 COMMITTEES

Section 1. All residents of Sun City Units 2, 3, 4 and 5 shall be eligible to serve on any committee.

Section 2. Standing Committees shall be appointed as follows, whose general duties shall be to make recommendations to the Activities Board as outlined below:

- a—Committee on Committees—To ascertain persons whose qualifications and availability are such as to recommend them for duty on certain committees.
- b—Finance Committee—All financial functions pertaining to Town Hall Center.
- c—Safety Committee—To provide rules and regulations regarding safety precautions and the elimination of hazards.
- d—Equipment and Hand Tools Committee—To review the use and care of Hand Tools and equipment, and to recommend the necessity for purchase of new equipment.
- e—Scheduling and Coordinating Committee—To schedule and coordinate all Activities in the Town Hall area.
- f—Entertainment Committee—To recommend special entertainment.
- g—Club Organization—To receive applications and to assist in the organization of recognized Clubs.
- h—Public Relations—To recommend means to create better relations between all residents of Sun City, and to provide information to new residents as to the facilities available.

Section 3. Special committees may be appointed as required.

ARTICLE 7 RECOGNIZED CLUBS

Section 1. In order for a Club to be recognized by the Activities Board, such Club shall comply with the following minimum requirements—

- a—It shall have at least ten members.
- b—It shall be organized with at least three officers, namely—Chairman, Vice-Chairman and Secretary-Treasurer.
- c—It shall hold regular meetings.
- d—Membership shall be open to all residents of Sun City Units 2, 3, 4 & 5.
- e—It shall not deny the use of its equipment and facilities to any resident of Sun City Units 2, 3, 4 and 5, provided such individual complies with the Rules and Regulations established by the Club.
- f—It shall be responsible for drawing up and enforcing Rules and Regulations for governing the use of tools, equipment and areas assigned to them for their activity.
- g—It shall inventory, accept and be responsible for tools and equipment turned over to them.

ARTICLE 8

NOMINATION AND ELECTION OF OFFICERS

Section 1. A nominating committee of five shall be selected by residents of Sun City Units 2, 3, 4 and 5 at a called meeting in October of each year. They shall elect their own chairman, and shall serve for a period of one year.

Section 2. They shall prepare a slate of not less than three persons for each office listed alphabetically.

Section 3. Within fifteen days after the October meeting, a copy of this slate shall be posted on the Town Hall Bulletin Board and published in the local newspaper.

Section 4. Within thirty days following the publication of the slate, a general meeting shall be held for the election of officers, at which time those having write-in candidates shall present them to the Nominating Committee at Town Hall.

Section 5. The slate as prepared by the Nominating Committee shall be listed on the blackboard, and all write-in candidates shall be listed alphabetically thereafter.

Section 6. Election of officers shall be by secret ballot,

and the one receiving the highest vote for each office shall be declared elected.

Section 7. Elected officers and newly elected Club Chairmen shall take office at a joint meeting with the retiring Activities Board members at the first meeting in January.

ARTICLE 9 NOMINATION AND ELECTION OF DIRECTORS

Section 1. The seven directors shall be elected by a majority vote of all club chairmen, from among the chairmen of the recognized clubs, and a meeting of the club chairmen shall be called by the chairman of the Activities Board during the first week in December for the purpose of electing the seven Directors.

Section 2. Newly elected Directors shall take office at a joint meeting the second Monday in January with the retiring Activities Board members.

ARTICLE 10 VACANCIES

Section 1. In case of vacancy in elected office, without sufficient reason acceptable by the Board, the Activities Board of Directors may appoint a member of the Town Hall Center in good standing to serve the unexpired term.

Section 2. In case of vacancy in the seven directors, exceeding two months, or by reason of a director becoming ineligible because of retiring from his office as club chairman, a replacement shall be elected by a majority vote of all club chairmen at a meeting called by the Chairman of the Activities Board.

ARTICLE 11

RECALL OF AN OFFICER

Section 1. Action on removal of any one of the four officers may be initiated by not less than fifty members of Town Hall Center, who shall submit their grievance in writing to the Chairman of the Activities Board. The Chairman of the Board shall publicize such request for a period of thirty days, within seven days after which a meeting shall be called of the Town Hall Center members for the purpose of voting on recall by secret ballot. In case the officer involved should be the Chairman of the Board, action shall be initiated by the Vice-Chairman. Two-thirds majority of members present and voting shall be necessary for recall.

Section 2. In event of recall, motion shall be taken in accordance with Article 10 of the By-laws.

ARTICLE 12 AMENDMENTS

Section 1. Action on changes and/or amendments to this Constitution and By-laws may be initiated in writing to the Activities Board by petition of at least fifty members of Town Hall Center. Such petition shall be publicized by the Activities Board for a period of thirty days.

Section 2. Within sixty days after publication of the proposed change and/or amendment, a general meeting shall be called for the purpose of voting by secret ballot on such change and/or amendment.

ARTICLE 13 QUORUM

Section 1. Two-thirds of the members of the Activities Board shall constitute a quorum at all Board meetings.

Section 2. A minimum of fifty members shall be required as a quorum for any membership meeting.

ARTICLE 14 MEETINGS

Section 1. Fifty members may file a request with the Secretary of the Board or the Chairman for a Town Hall Center membership meeting for any purpose. The Board shall call such a meeting within ten days after receiving such a request.

ARTICLE 15 PROCEDURE

Section 1. All meetings of the Activities Board shall be conducted in accordance with this Constitution and By-laws, and Roberts' Rules of Order as revised.

COMMUNITY FACILITIES AGREEMENT

Date _____

I realize and understand that the community recreation facilities located at the northeast corner of Peoria Avenue and 107th Avenue, Sun City, Arizona, are presently owned and controlled by the Del E. Webb Development Co., and are being maintained and operated by that company.

I further understand that at a time when the homes in that vicinity are substantially occupied by home owners such as myself, the Del E. Webb Development Co. will convey, at no cost to me, the entire community facilities to a non-profit corporation formed by the Del E. Webb Development Co. for the benefit of the home owners. I realize that while this transfer will be free to me as a home owner, subsequently the operation and maintenance of the community facilities will be an expense of the non-profit corporation whose members will be the home owners. I agree to pay the assessments deemed necessary by the Board of Directors of the non-profit corporation for the operation and maintenance of the community facilities when the same are transferred. It is understood, however, that the transfer to the non-profit corporation will not be made by the Del E. Webb Development Co. until such time as there are sufficient home owners so that not more than Twenty Dollars (\$20.00) of annual operating costs of the community facilities are attributed to each resident home owner, or if transferred before said time by Webb, Webb agrees to pay the actual operating costs over \$20.00 per resident home owner.

Until the transfer mentioned above has taken place, I agree to pay annually and in advance to the Del E. Webb Development Co., or the non-profit corporation mentioned above, the sum of One Dollar (\$1.00) per month for each resident in the home which I am purchasing until the property is transferred to the non-profit group and different arrangements are made by the governing body of that group. This annual payment shall be on a calendar year basis and the first payment shall cover the period commencing with the home owner's pro-ration date and shall be paid through escrow.

I further agree that in the event of any future sale of my home that the above understanding and agreement will be made a part of the Sales Contract and an obligation of the buyer.

I agree also that my purchase of a home in the Sun City community is subject to my acceptance as a member of the association which will maintain and own the community recreational facilities, such acceptance to be given by the entity in control of those facilities at the time of my purchase.

I agree that in any subsequent sale, assignment or lease of my home by me that, as a condition of such transfer, any purchaser, assignee or lessee of me shall be subject to the same requirement. Any sale, assignment or lease without such written acceptance by the entity controlling the community facilities being deposited in escrow shall be void and of no effect.

 Purchaser

 Purchaser

Copy

BUILDING LAYOUT UNDER ROOF OF NORTH TOWN HALL

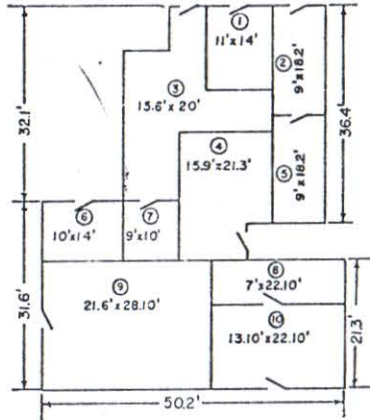

ARTS & CRAFTS BLDG(OLD)
2761 SQ FT

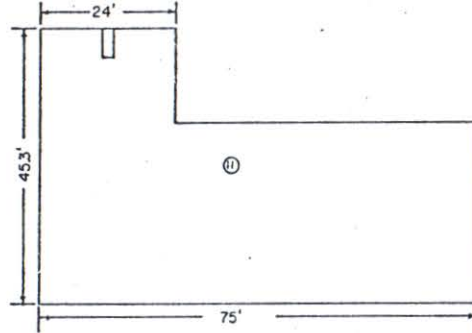

SWIMMING POOL
3400 SQ FT

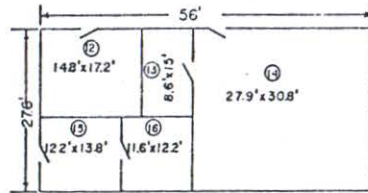

ARTS & CRAFTS BLDG(NEW)
1545 SQ FT

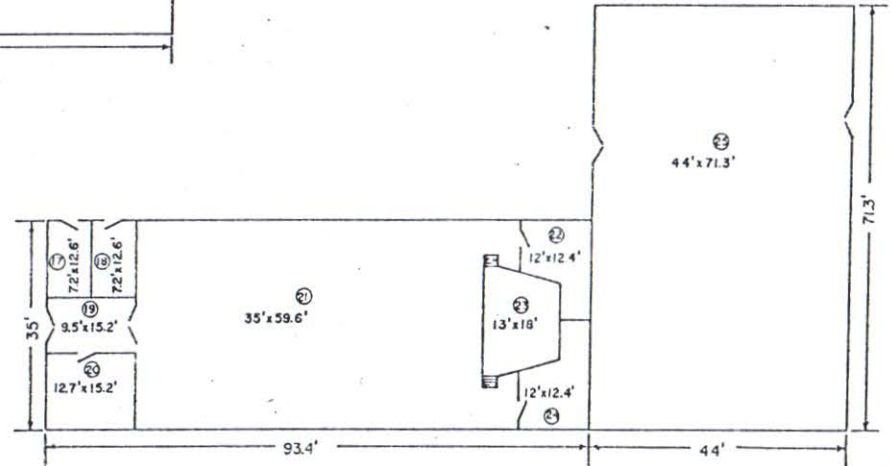

AUDITORIUM BLDG
3269 SQ FT

MENS CLUB BLDG
3137 SQ FT

1- EQUIPMENT STORAGE	154	SQ FT
2- POOL PUMP ROOM	164	
3- MAINTENANCE ROOM	312	
4- LADIES DRESSING ROOM (POOL)	339	
5- STORAGE ROOM	164	
6- LAWN BOWLING STORAGE	140	
7- MAINTENANCE STORAGE	90	
8- LAPIDARY STORAGE	155	
9- CERAMIC ROOM	607	
10- LAPIDARY ROOM	290	
11- SWIMMING POOL	3400	
12- MENS DRESSING ROOM (POOL)	255	
13- STORAGE ROOM	129	
14- ART ROOM	859	
15- RECEPTION ROOM	168	
16- MANAGERS OFFICE	142	
17- MENS TOILET	90	
18- LADIES TOILET	90	
19- VESTIBULE	144	
20- KITCHEN	193	
21- AUDITORIUM	2086	
22- STORAGE ROOM	149	
23- STAGE	234	
24- STORAGE ROOM	149	
25- MENS CLUB	3137	
TOTAL	13640	

SCALE $\frac{1}{8}$ " = 1 FT

BUILDING LAYOUT UNDER ROOF OF CENTER TOWN HALL

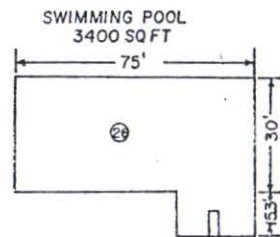
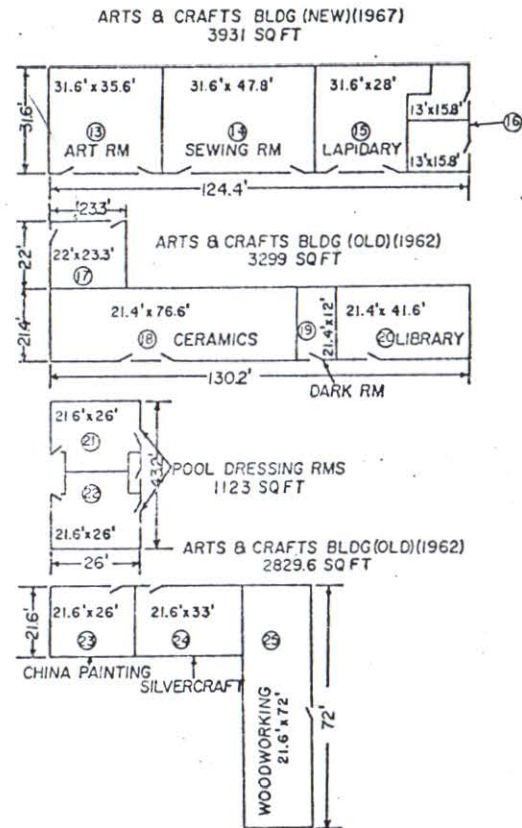
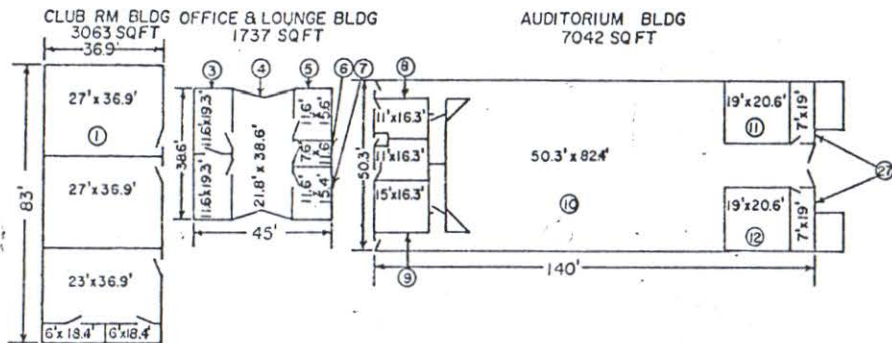

Room Number	Description	Area (SQ. FT.)
1-3	CLUB ROOMS, B-1-2-3	2,841
2	STORAGE AREA	220
3	BUSINESS OFFICE	447
4	LOUNGE	842
5	MANAGERS OFFICE	180
6	OFFICE MANAGERS OFFICE	88
7	ACCOUNTANT & BOOKKEEPER	180
8	PUBLIC TOILETS	358
9	KITCHEN	245
10	AUDITORIUM, A-1-2	4,145
11	AUDITORIUM, A-3	392
12	AUDITORIUM, A-4	392
13	ART ROOM	1,125
14	SEWING ROOM	1,510
15	LAPIDARY	885
16	STORAGE AREA	410
17	CONFERENCE ROOM	513
18	CERAMICS	1,639
19	DARK ROOM	257
20	LIBRARY	890
21	POOL DRESSING ROOM (MEN)	562
22	POOL DRESSING ROOM (WOMEN)	562
23	CHINA PAINTING	562
24	LEATHERCRAFT & SILVERCRAFT	713
25	WOODWORKING	1,555
26	SWIMMING POOL	3,400
27	STORAGE AREA	266
TOTAL		26,827

SCALE $\frac{1}{16}$ IN = 1 FT

BUILDINGS UNDER ROOF AT SOUTH TOWN HALL

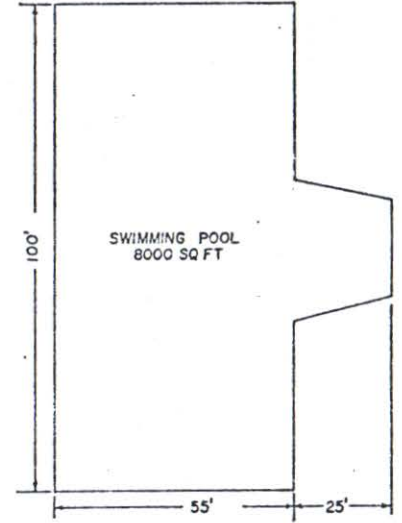
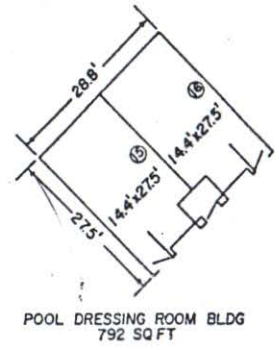
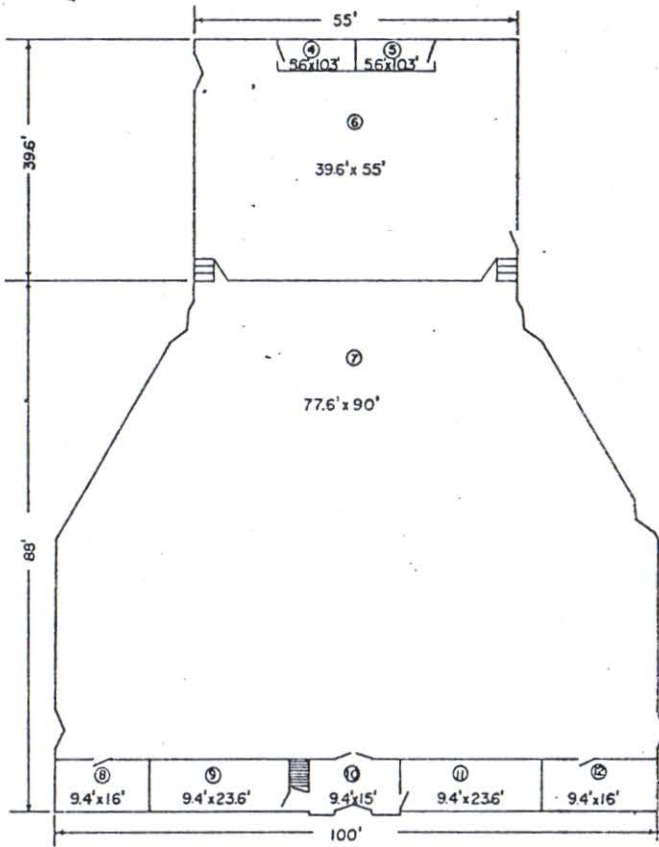
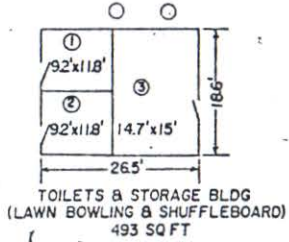

1- MENS TOILET	109	SQ FT
2- LADIES TOILET	109	" "
3- STORAGE ROOM	220	" "
4- LADIES TOILET	58	" "
5- MENS TOILET	58	" "
6- STAGE	2178	" "
7- AUDITORIUM	6983	" "
8- STORAGE ROOM	150	" "
9- MENS TOILET	222	" "
10- VESTIBULE	141	" "
11- LADIES TOILET	222	" "
12- STORAGE ROOM	150	" "
13- SNACK BAR	156	" "
14- KITCHEN	406	" "
15- MENS SHOWER & DRESSING RM	396	" "
16- LADIES SHOWER & DRESSING RM	396	" "
17- EXERCISE ROOM	1253	" "
18- LADIES SHOWER & DRESSING RM	327	" "
19- MENS SHOWER & DRESSING RM	327	" "
20- THERAPY POOL ROOM	799	" "
21- HALLWAY	151	" "
22- STORAGE ROOM	99	" "
23- STORAGE ROOM	82	" "
TOTAL	14,992	" "

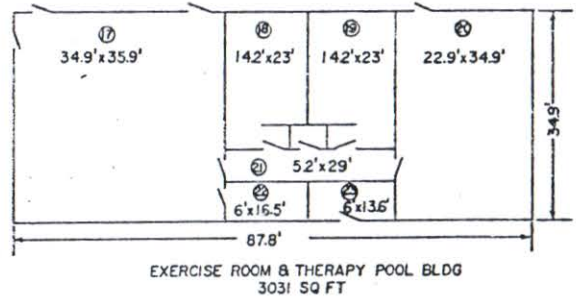
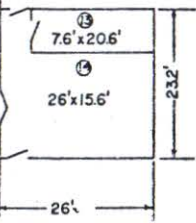

Leland D. Cornell
President

A. Lambert Bergman
Vice President



Bertha A. Roberts
Treasurer

John E. Davis
Secretary

Sun City

A R I Z O N A

Phone 933-5281

Zip Code 85351

Town Hall Center

10600 Peoria Ave.

Since January 1, 1965, Town Hall Center has become a private club, owned by its members and operated for their benefit. Membership consists of those Town Hall area home owners who signed the Facilities Agreement and have paid the 1965 membership dues. In other words, through their membership in the Town Hall Center, a non-profit corporation, they own the \$450,000 Town Hall Complex, which in itself adds much to the value of their home.

The estimated cost of operating the Town Hall Center for 1965, is \$80,000 which includes \$15,000 in case the Federal Government requires us to pay the 20% excise tax. You no doubt have noticed how nice the grounds and buildings appear, I am sure you will agree your House Committee has kept them in excellent condition since we took over on January 1. The grounds are maintained in fine condition by a reputable company on a contract basis.

Our total payroll expense is for two maintenance men, one janitorial service (mostly night work) and our office secretary (Mrs. Helen Foster). Our only source of income to operate the Town Hall Complex is annual membership dues, of \$20.00 per Town Hall resident. A very low membership fee for a private club, of the Country Club caliber, something we can be justly proud to show our friends and visitors.

The Town Hall members who received their keys after the 1st of February, 1964, only pay the dues for the period of 1965 remaining. For instance if you received your keys on April 1, 1964, your 1965 dues will be prorated for the nine months between April 1 and December 31, 1965. Thereafter your dues will be on an annual basis. Payable on or before January 1. In checking our records recently we note your 1965 dues are not paid, perhaps you have overlooked this. Your dues for the balance of 1965 are \$

We now have about 30 craft and social clubs and all the officers of these clubs contribute their time and efforts to provide activities that will be of interest to all the members. Your cooperation in maintaining your membership helps to carry on this work, and to expand it to new activities.

Won't you please visit the Town Hall office, 10600 Peoria Avenue and see our secretary about your 1965 dues. We deeply appreciate your help and cooperation.

Sincerely yours,

Leland D. Cornell, Pres.
Town Hall Center Board.

LDC:hcf

Dear Folks:

Did you forget that your 1965
Membership Cards for Town Hall Center are
ready?

You can pick them up or if you
send a check in amount of \$-----
we will be glad to mail your cards to
you.

Please let us hear from you.

SUN CITY TOWN HALL CENTER

10,600 Peoria

Phone: 933-5281

.....1965
Your Town Hall Activities Membership expires on
In order to make our records uniform, we are accepting fees from the
expiration date of your membership cards to the last of December
1965 prorated.

The amount due to bring your cards up to date for 1965 is \$.....,
payable at the office of the Secretary, located off the Lounge at Town
Hall. Make checks payable to: SUN CITY TOWN HALL CENTER.

TOWN HALL CENTER
10600 Peoria Avenue
SUN CITY, ARIZONA
Phone: 933-5281

COMMUNITY FACILITIES AGREEMENT

Date _____

I realize and understand that the community recreation facilities located at the northeast corner of Peoria Avenue and 107th Avenue, Sun City, Arizona, are presently owned and controlled by the Del E. Webb Development Co., and are being maintained and operated by that company.

I further understand that at a time when the homes in that vicinity are substantially occupied by home owners such as myself, the Del E. Webb Development Co. will convey, at no cost to me, the entire community facilities to a non-profit corporation formed by the Del E. Webb Development Co. for the benefit of the home owners. I realize that while this transfer will be free to me as a home owner, subsequently the operation and maintenance of the community facilities will be an expense of the non-profit corporation whose members will be the home owners. I agree to pay the assessments deemed necessary by the Board of Directors of the non-profit corporation for the operation and maintenance of the community facilities when the same are transferred. It is understood, however, that the transfer to the non-profit corporation will not be made by the Del E. Webb Development Co. until such time as there are sufficient home owners so that not more than Twenty Dollars (\$20.00) of annual operating costs of the community facilities are attributed to each resident home owner, or if transferred before said time by Webb, Webb agrees to pay the actual operating costs over \$20.00 per resident home owner.

Until the transfer mentioned above has taken place, I agree to pay annually and in advance to the Del E. Webb Development Co., or the non-profit corporation mentioned above, the sum of Twenty Dollars (\$20.00) per year for each resident in the home which I am purchasing until the property is transferred to the non-profit group and different arrangements are made by the governing body of that group. This annual payment shall be on a calendar year basis and the first payment shall cover the period commencing with the home owner's possession and shall be paid through escrow.

I further agree that in the event of any future sale of my home that the above understanding and agreement will be made a part of the Sales Contract and an obligation of the buyer.

I agree also that my purchase of a home in the Sun City community is subject to my acceptance as a member of the association which will maintain and own the community recreational facilities, such acceptance to be given by the entity in control of those facilities at the time of my purchase.

I agree that in any subsequent sale, assignment or lease of my home by me that, as a condition of such transfer, any purchaser, assignee or lessee of me shall be subject to the same requirement. Any sale, assignment or lease without such written acceptance by the entity controlling the community facilities being deposited in escrow shall be void and of no effect.

Purchaser

Purchaser

copy

1965

SUN CITY - YOUNGTOWN NEWS-SUN

Town Criers Organize to Aid Communications

In addition to Sun City's more than 100 clubs and organizations formed last week when a meeting was held in Town Hall to organize the Town Criers Club. The meeting was attended by about 50 persons with Lambert Forrester as temporary chairman and Forrest Fullerton as chairman.

The purposes of the club are (1) to improve communications between the Town Hall Center and its members, (2) act as information carriers in the various areas, (3) encourage new and old residents to get acquainted with the various clubs and their activities, (4) recommend to the Town Hall Committees the names of persons in their area who may be well qualified for advisory or appointive offices in the Town Hall complex, (5) recall changes of the status of persons in their area, and (6) act as a reception committee and hostesses at all Town Hall Center orientation meetings.

The club's first project is to contribute to all Town Hall members the Town Hall Club News, a catalog of all the clubs and their activities and a brief description of how Town Hall is operated.

A survey is also being made to determine the interests of all members for the purpose of planning as many activities as needed to meet the requirements of Town Hall members. The organization consists of captains who head districts. They are assisted by area mem-

Ave.; Helen Curtis, 11007 Elk Ave.

Virgil Williams, captain, 10046 Sun City Blvd.; Dewey Thomas, 10101 Sun City Blvd.; Ansel Brooks, 10229 Sun City Blvd.; F. Hugh Kelley, 11401 Coggins Dr.; Frank Springer, 10124 Palmer Dr.; E. T. Wells, 10109 Pebble Beach Dr.

Henry Jacobs, captain, 10028 Peoria Ave.; Verne Hamborg, 10007 Lakeview Circ.; P. E. Fader, 9941 Eldorado Dr.; Jerry Turner, 9935 La Jolla

Glenn Park, captain, 10430 Snead Dr.; C. M. Sagmoen, 10325 Monterosa Dr.; Scot Coulter, 10337 Snead Dr.; Gerald Carrier, 10613 Hope Dr.

Laird Fryer, captain, 11453 Balboa Dr.; Donald Scott, 11838 Mission Dr.

Quarter members are:

Forrest Fullerton, captain, 10301 Audrey Ave.; Nelson Corner, 10363 Audrey Ave.; Royal Handy, 10638 Camden Ave.; William Chapman, 10602 Cumberland Ave.

Earl Holmes, captain, 10135 Desert Hills Dr.; Leonard De Mars, 10020 Riviera Dr.; Les Behnke, 10026 Riviera Dr.; William Prinsloo, 10031 Desert Hills Dr.; Thomas Jennings, 10230 Desert Hills Dr.; Delbert Scruby, 9949 Alabama Ave.; Harold Rissler, 10219 Alabama Ave.; Art Evans, 11423 103rd Ave.

Earl Daniels, captain, 11226 109th Ave.; Grover Adams, 10815 100th Ave.; Charles Dawson, 10809 Madison Dr.; Helen De Jarnette, 11223 110th Dr.; Fred Feekin, 10728 Abbott Ave.

E. Jack Jackley, Captain, 10615 102nd Dr.; Joe Hartigan, 10150 Pinehurst Dr.; Earl Bob Robinson, 10247 No. Snead Circ.; Glenn Wilson, 10324 Willie Low; Harold Terhune, 10629 103rd Ave.

Edward Austin, captain, 10747 Hope Dr.; Floyd Baker, 10741 Hope Dr.; Wendell Noell, 10750 Crosby Dr.; Henry Painter, 10738 Crosby Dr.; Albert Kampschror, 10727 El Dorado Dr.; Earl Emmerman, 10802 El Dorado Dr.; Joe Favre, 10713 El Dorado Dr.; Margaret Cook, 11409 109th Ave.

Sarah Nelson, captain, 11032 Sun City Blvd.; Margaret Diggs, 10854 Canterbury Dr.; Dudley Diggs, 10854 Canterbury Dr.; Louis Snell, 11022 Connecticut Dr.; Emily Barr, 11050 Florida

MARCH, 1964

TOWN HAL

Sun.	Mon.	Tues.
1 9:30 Presbyterian Church 11:00 Episcopal Church	2 9:00-5:00 Ceramics 9:30 Gymnastics 10:00 Sewing - Charity 1:00 Lawn Bowling Meet. 1:00 Art Class 1:30 Friends of Library 1:45 Lawn Bowling 7:30 Movies	3 9:00 Ceramics Molding 9:00 Sewing Class 9:30 Shuffleboard Meet. 10:00 Agriculture Meet. 12:45 Ladies Dupl. Bridge 1:00 Art Class 1:00 Art Club Meet. 3:00 Highfield Chorus 7:00 Duplicate Bridge 7:30 Ceramics Instruc.
8 9:30 Presbyterian Church 11:00 Episcopal Church	9 9:00-5:00 Ceramics 9:30 Gymnastics 10:00 Sewing Charity 1:00 Art Class 1:45 Lawn Bowling 7:30 Movies	10 9:00 Ceramics Molding 9:00 Sewing Class 9:30 Shuffleboard 12:45 Ladies Dupl. Bridge 1:00 Art Class 3:00 Highfield Chorus 7:00 Duplicate Bridge 7:30 Ceramics Instruc.
15 9:30 Presbyterian Church 11:00 Episcopal Church	16 9:00-5:00 Ceramics 9:30 Gymnastics 1:00 Art Class 1:45 Lawn Bowling 5:00-6:30 Episcopal Church 7:30 Movies	17 9:00 Ceramics Molding 9:00 Sewing Class 9:30 Shuffleboard 12:45 Ladies Dupl. Bridge 1:00 Art Class 3:00 Highfield Chorus 5:00-6:30 Episcopal Church 7:00 Duplicate Bridge 7:30 Ceramics Instructions
22 9:30 Presbyterian Church 11:00 Episcopal Church	23 9:00-5:00 Ceramics 9:30 Gymnastics 10:00 Sewing-Charity 1:00 Art Class 1:45 Lawn Bowling 7:30 Movies	24 9:00 Ceramics Molding 9:00 Sewing Class 9:30 Shuffleboard 12:45 Ladies Dupl. Bridge 1:00 Art Class 3:00 Highfield Chorus 7:00 Duplicate Bridge 7:30 Ceramics Instruction
29 EASTER SUNDAY 9:30 Presbyterian Church 11:00 Episcopal Church	30 9:00-5:00 Ceramics 9:30 Gymnastics 1:00 Art Class 1:45 Lawn Bowling 7:30 Movies	31 9:00 Ceramics Molding 9:00 Sewing Class 9:30 Shuffleboard 12:45 Ladies Dupl. Bridge 12:00 Sr. Womens Golf Box Lunch 1:00 Art Class 3:00 Highfield Chorus 7:00 Duplicate Bridge 7:30 Ceramics Instruction

ACTIVITIES CALENDAR

Sun City, Arizona

Wed.	Thur.	Fri.	Sat.
<p>4</p> <p>8:30 Drivers Licenses 9:00 Stitch & Knit Club 9:30 Womens Chorus 9:30 Art Class 9:30 Bridge Lessons 1:00 Copper Enameling 1:45 Lawn Bowling 7:30 Bridge Lessons 7:30 Presbyterian-Lentin 7:30 Civil Defense</p>	<p>5</p> <p>8:30 Drivers Licenses 9:00 Ceramics Molding 9:30 Shuffleboard 10:00 Lawn Bowling Inst. 10:00 Presbyterian Choir 1:00 Leathercraft 1:00 Puppet Club-Sewing 1:00 Art Class 1:30 Swim Club Meeting 3:30 Episcopal Choir 7:30 Bridge & Canasta</p>	<p>6</p> <p>9:00 Mosaics 9:30 Trailer Club Meet 1:00 Ladies Bridge 1:00 Art Class 1:30 Lapidary Meeting 1:45 Lawn Bowling</p> <p>6:00 Dance Class</p>	<p>7</p> <p>9:30 Shuffleboard</p> <p>8:30 Ballroom Dancing</p>
<p>11</p> <p>8:30 Drivers Licenses 9:00 Stitch & Knit 9:30 Womens Chorus 9:30 Art Class 9:30 Bridge Lessons 1:00 Copper Enameling 1:45 Lawn Bowling 7:30 Bridge Lessons 7:00 Mens Club 7:30 Camera Club 7:30 Civil Defense Meet.</p>	<p>12</p> <p>8:30 Drivers License 9:00 Ceramic Molding 9:30 Shuffleboard 10:00 Lawn Bowling Inst. 10:00 Presbyterian Choir 1:00 Leathercraft 1:00 Puppet Club-Sewing 1:00 Art Class 3:30 Episcopal Choir 7:30 Bridge & Canasta</p>	<p>13</p> <p>9:00 Mosaics</p> <p>1:00 Ladies Bridge 1:00 Art Class 1:45 Lawn Bowling</p> <p>6:00 Dance Class</p>	<p>14</p> <p>9:30 Shuffleboard</p> <p>8:30 Ballroom Dancing</p>
<p>18</p> <p>8:30 Drivers License 9:00 Stitch & Knit 9:30 Womens Chorus 9:30 Art Class 9:30 Bridge Lessons 1:00 Copper Enameling 1:45 Lawn Bowling 5-6:00 Episcopal Church 7:30 Bridge Lessons 7:30 Presbyterian-Lentin 7:30 Camera Club 7:30 Civil Defense Meet.</p>	<p>19</p> <p>8:30 Drivers License 9:00 Ceramics Molding 9:30 Shuffleboard 10:00 Lawn Bowling Inst. 10:00 Sr. Womens League 1:00 Leathercraft 1:00 Puppet Club-Sewing 1:00 Art Class 3:30 Episcopal Choir 7:30 Bridge & Canasta</p>	<p>20</p> <p>9:00 Mosaics</p> <p>1:00 Ladies Bridge 1:00 Art Class 1:45 Lawn Bowling</p> <p>6:00 Dance Class</p>	<p>21</p> <p>9:30 Shuffleboard</p> <p>10:00 Woodworking Meet.</p> <p>8:30 Ballroom Dancing</p>
<p>25</p> <p>8:30 Drivers License 9:00 Stitch & Knit Club 9:30 Womens Chorus 9:30 Art Class 9:30 Bridge Lessons 1:00 Copper Enameling 1:45 Lawn Bowling</p> <p>7:30 Bridge Lessons 7:30 Lenten Service 7:30 Camera Club 7:30 Civil Defense Meet.</p>	<p>26</p> <p>8:30 Drivers License 9:00 Ceramics Molding 9:30 Shuffleboard 9:30 Home Owners Bd. Meet. 10:00 Lawn Bowl Inst. 10:00 Presbyterian Choir 1:00 Leathercraft 1:00 Puppet Club-Sewing 1:00 Art Class 3:30 Episcopal Choir 7:30 Bridge & Canasta</p>	<p>27 GOOD FRIDAY</p> <p>9:00 Mosaics</p> <p>1:00 Ladies Bridge 1:00 Art Class 1:45 Lawn Bowling</p> <p>6:00 Dance Class</p>	<p>28</p> <p>9:30 Shuffleboard</p> <p>8:30 Ballroom Dancing</p>

Library Hours
 Monday thru Friday
 10:00-12:00 Noon
 Friday-6:00-8:00

OTHER CHURCHES IN SUN CITY
 Catholic - 10625-111th Ave. 8:00-9:30-11:00
 Christian Science - Community Center-Friday 8:00P.M.
 Jewish Church - Community Center-Friday 8:00P.M.
 Latter Day Saints - Community Center 7:00 P.M. Sunday
 Lutheran Church - 11025-111th Avenue
 United Church-107th Ave. & Sun City Blvd. 9:30 & 11:00

Your Town Hall Activities Membership has expired.

Please stop by the Town Hall Lounge with your remittance - or

you may mail check payable to: TOWN HALL CENTER

10600 Peoria Avenue

Sun City, Arizona.

Phone: 933-

To1965

Your Town Hall Activities Membership expires on
In order to make our records uniform, we are accepting fees from the
expiration date of your membership cards to the last of December
1965 prorated.

The amount due to bring your cards up to date for 1965 is \$.....,
payable at the office of the Secretary, located off the Lounge at Town
Hall. Make checks payable to: SUN CITY TOWN HALL CENTER.

TOWN HALL CENTER
10600 Peoria Avenue
SUN CITY, ARIZONA
Phone: 933-5281

Your Town Hall Activities Membership has expired.

Please stop by the Town Hall Lounge with your remittance - or

you may mail check payable to: TOWN HALL CENTER

10600 Peoria Avenue

Sun City, Arizona.

VF - RECREATION CENTERS - FAIRWAY (TOWN HALL)



OWN HALL RECREATIONAL ACTIVITIES CENTER

POST OFFICE BOX 555

DEL WEBB'S
Sun City
A R I Z O N A

(SAMPLE LETTERHEAD)

COMMUNITY FACILITIES AGREEMENT

Date August 26, 1963

I realize and understand that the community recreation facilities located at the northeast corner of Peoria Avenue and 107th Avenue, Sun City, Arizona, are presently owned and controlled by the Del E. Webb Development Co., and are being maintained and operated by that company.

I further understand that at a time when the homes in that vicinity are substantially occupied by home owners such as myself, the Del E. Webb Development Co. will convey, at no cost to me, the entire community facilities to a non-profit corporation formed by the Del E. Webb Development Co. for the benefit of the home owners. I realize that while this transfer will be free to me as a home owner, subsequently the operation and maintenance of the community facilities will be an expense of the non-profit corporation whose members will be the home owners. I agree to pay the assessments deemed necessary by the Board of Directors of the non-profit corporation for the operation and maintenance of the community facilities when the same are transferred. It is understood, however, that the transfer to the non-profit corporation will not be made by the Del E. Webb Development Co. until such time as there are sufficient home owners so that not more than Twenty Dollars (\$20.00) of annual operating costs of the community facilities are attributed to each resident home owner, or if transferred before said time by Webb, Webb agrees to pay the actual operating costs over \$20.00 per resident home owner.

Until the transfer mentioned above has taken place, I agree to pay annually and in advance to the Del E. Webb Development Co., or the non-profit corporation mentioned above, the sum of Twenty Dollars (\$20.00) per year for each resident in the home which I am purchasing until the property is transferred to the non-profit group and different arrangements are made by the governing body of that group. This annual payment shall be on a calendar year basis and the first payment shall cover the period commencing with the home owner's possession and shall be paid through escrow.

I further agree that in the event of any future sale of my home that the above understanding and agreement will be made a part of the Sales Contract and an obligation of the buyer.

I agree also that my purchase of a home in the Sun City community is subject to my acceptance as a member of the association which will maintain and own the community recreational facilities, such acceptance to be given by the entity in control of those facilities at the time of my purchase.

I agree that in any subsequent sale, assignment or lease of my home by me that, as a condition of such transfer, any purchaser, assignee or lessee of me shall be subject to the same requirement. Any sale, assignment or lease without such written acceptance by the entity controlling the community facilities being deposited in escrow shall be void and of no effect.

Joe F. Rice
Purchaser

Lair M. Rice
Purchaser

TOWN HALL NEWS

Published In The Interest Of Town Hall Members SUN CITY, ARIZONA

March, 1966

Who Are The Owners Of Town Hall?

A little over a year ago the Del E. Webb Corporation turned the facilities of Town Hall over to the home owners of Units 2, 3, 4, 5 and 6 or subsequent beneficial and/or legal owners living within these units. This means that each and every one of us residing in the above mentioned area is a part owner of the Town Hall facilities, lock, stock and barrel; the land, the buildings, swim pool, and all fixtures and equipment.

In view of the fact that we are not a legally organized community or legal political sub-division, there can be no tax levied to defer the cost of operation and maintenance of the facilities for the enjoyment and use of the members, as well as for the enhancement of the value of our individual homes. It is necessary therefor, to levy a fee for that purpose. At present that fee is \$20.00 for each person living in the area. As the population of the area grows, this fee could be lowered. This is the fee that we agreed to pay at the time we signed the other contracts and agreements for the purchase of our homes.

Each year when we pay our dues to the organization, we receive a membership card which entitles us to the use of the facilities without

TOWN HALL BOARD OF DIRECTORS	
Elected December 7, 1965	
PRESIDENT	Burr O. Welch, 10828 Peoria Avenue ----- Phone 933-0319
VICE PRESIDENT	William Chapman, Jr., 10602 Cumberland Drive - Phone 933-5473
TREASURER	Bertha A. Roberts, 10748 Hope Drive ----- Phone 933-2200
SECRETARY	Louise F. Poehls, 10836 Hope Drive ----- Phone 933-2417
CHAIRMAN OF HOUSE COMMITTEE	Clyde P. Wells, 10148 Desert Hills Drive ----- Phone 933-2088
CHAIRMAN OF FINANCE COMMITTEE	Taylor Smith, 10932 Sun City Boulevard ----- Phone 933-3490
CHAIRMAN OF LEGAL COMMITTEE	T. Karl Dimmitt, 11419, 109th Avenue ----- Phone 933-2614
CHAIRMAN OF CLUB ORGANIZATION COMMITTEE	Earl M. Holmes, 10135 Desert Hills Drive ----- Phone 933-2990
CHAIRMAN OF SAFETY COMMITTEE	Leland T. Teal, 10740 El Dorado Drive ----- Phone 933-2708
CHAIRMAN PUBLIC RELATIONS COMMITTEE	Forrest H. Fullerton, 10301 Audrey Drive ----- Phone 933-4675
CO-CHAIRMAN PUBLIC RELATIONS COMMITTEE	Ruth S. Finch, 9915 Edward Drive ----- Phone 933-4979

any further cost. However, there are clubs and groups within the facilities you may join, which have nominal membership fees.

Each membership card holder is entitled to bring two house guests who may participate in any of the facilities, provided that the card holder is present at the time his or her guest is using the facilities. Also a card holder may purchase one guest card for a houseguest for

one dollar, which entitles the guest to the use of the facilities for a period of three months. A second guest card may be purchased by each card holder for \$1.67 per month, or \$5.00 for a three-month period.

The Town Hall area is the show place of our community. It is the reason most of us selected Sun City as a place of residence and we are justly proud of it.

TOWN HALL CLUBS

Agriculture Club

Jack Shafer
933-1606
First Tuesday, 10:00 a.m.

Amateur Radio Club

Sam Davenport
933-1549
3rd Tuesday, 7:30 p.m.

Art Club

Hall Abrisch
933-2980
2nd Tuesday, 12:30 p.m.

Bridge Clubs

DUPLICATE
Mrs. Maud Mary Fiedler
933-5471
Wednesday, 7:00 p.m.

DUPLICATE - LADIES

Mrs. Sidney Showers
933-3515
Thursday, 12:45 p.m.

GOREN BRIDGE

Miss Rachel Bell
933-3397
Tuesday, 7:30 p.m.

THURSDAY BRIDGE

Herbert S Pahren
933-4339
7:30 p.m.

BRIDGE - LADIES

Mrs. Glaphy Brown
933-3509
Friday, 1:00 p.m.

Camera Club

Warren A. Donaldson
933-3439
Wednesdays, 7:30 p.m.

Ceramic Club

Mrs. Velma Gibson
933-3493
First Monday, 9:00 a.m.

Chorus

SUN CITY MIXED
Lawrence A. Armstrong
933-1426
Tuesdays, 3:00 p.m.

MEN'S

Mark Cassells
933-0397
Saturdays, 9:00 a.m.

WOMEN'S

Mrs. Ethel Murphey
933-2672
Wednesdays, 9:30 a.m.

Coin Club

Joe M. Dempf
933-1413
2nd & 4th Thursdays, 7:30 p.m.

Copper Enameling

Mrs. Dolores Allen
933-4433
Mon., Tues., Wed., 9:00 a.m.

Dance Club

Bill Prinsloo
933-4910
Saturdays, 8:30 p.m.

Daughters Of The Nile

Mrs. Ercell Baker
933-4448
First Monday, 10:00 a.m.

Friend Of The Library

Mrs. Iva Zeigler
933-6587
1st Monday, 1:30 p.m.

Gymnastics - Ladies

Mrs. Grace Glenn
933-2655
Mondays, 9:15 a.m.

Lapidary Club

P. E. Fader
933-4488
Fridays, 1:30 p.m.

Lawn Bowling Club

Roy W. Wolfgang
933-1716
First Monday, 1:00 p.m.

Leathercraft

Mrs. Laudine Juriga
933-0373
Thursday, 1:00 p.m.

Men's Club

Mr. Myron Stevens
933-1070
2nd & 4th Wednesday, 7:30 p.m.

Mosaics Club

Mrs. Dot Reinville
933-5498
1st Friday, 9:00 a.m.

Pinochle Club

Mr. Les Behnke
933-4805
Saturdays, 1:00 p.m.

Puppet Club

Mrs. Margaret Nygren
933-2198
Thursdays, 9:00 a.m.

Rock Hound Club

Claude Cherry
933-2198
2nd Monday, 7:30 p.m.

Rose & Garden So.

Wm. J. McDonnal
933-3672
2nd Tuesday, 7:30 p.m.

Rhythm Ramblers

Orvil Esher
933-4169
Wednesdays, 2:00 p.m.

Sen Women's League

Mrs. Helen Frederickson
933-1858
3rd Thursday, 10:00 a.m.

Shuffleboard

Fred Feekin
933-4482
1st Tuesday, 1:00 p.m.

Stitch & Knit

Mrs. Evelyn Miner
933-5388
Wednesdays, 9:00 a.m.

Swim Club

Ralph H. Steinberg
933-5456
1st Thursday, 1:30 p.m.

Travel Trailer

Carl E. Jellum
933-3271
1st Friday, 9:30 a.m.

Twirl Sq. Dancers

Wendell Noell
933-2634
Fridays, 7:00 p.m.

Woodworking

Paul Wise
933-5479
3rd Monday, 10:00 a.m.

Singles Club

Margaret Gatzweiler
933-3875
United Church

Town Hall Movies

Mondays, 7:30 p.m.

TOWN CRIERS GROUP

The Town Criers are a group of eighty or more residents of the Town Hall area, who were organized under the public relations committee. They are members living in the various sections of Town Hall units, and are charged with the distribution of information concerning Town Hall. They are friends in your area who may be contacted for information on any questions you might have concerning the activities of the center.

There are many activities available at Town Hall Center and all are for the enjoyment or enlightenment of the residents of the area. We believe that most any interest you may have, is available or can be arranged in connection with the center. Listed here are some of the activities offered:

- Shuffleboard
- Lawn Bowling
- Bridge
- Pinochle
- 500 & Canasta
- Horse Shoe
- Swimming
- Little Theatre
- Art (Painting)
- Sewing
- Knitting
- Ceramics
- Leathercraft
- Mosaic
- Lapidary
- Ballroom Dancing
- Square Dancing
- Woodworking

Other club activities available: Coin Club, Camera Club, Rose and Garden Club, Ladies Gymnastics, Men's Club and Senior Women's League.

You should make it a point to become acquainted with these public spirited residents of the area.

STATEMENT OF PRINCIPLE FOR TOWN HALL CENTER

The Board of Directors of Town Hall Center in the regular monthly meeting of March 2, 1964, approved the "STATEMENT OF PRINCIPLE" as recommended by the House Committee which follows:

The facilities of Town Hall Center are for the use of all persons holding current Town Hall Center Membership cards and their house guests.

Members of Recognized Town Hall Clubs shall not have special advantages over non-club members in the use of Craft Facilities.

For the Safety and Protection of all Town Hall Center members, the Recognized Club shall formulate rules and safety regulations covering the use of tools and/or equipment utilized by Club Members and Non-Club Members. (Per By-Law of Sun City Town Hall Center, Article VII, Section 1, paragraph d). All such rules and regulations must be submitted to the CLUB ORGANIZATION COMMITTEE for their approval. Approved rules and regulations must be posted in the area used by the club.

The facilities in the Arts & Crafts Rooms are for hobbies and not for the manufacture of articles to be sold by individuals for private gain.

Recognized clubs may offer for sale, articles made in the Arts & Crafts rooms provided the profit is retained by the club.

Recognized clubs may employ instructors, entertainers, etc., for the benefit of and by the request of its members. Fees, if any, are to be collected by the club.

A RECOGNIZED CLUB is a group of 25 or more Town Hall residents who have formed a club for a specific purpose. Their by-laws are approved by the Club Organization Committee as being not restrictive to other members of Town Hall.

TOWN HALL CORPORATION MEETINGS
 (Open to all Town Hall Members)
 Meets the second Monday in
 January, May, September and
 November.

RULES OR ASSIGNING SPACE IN TOWN HALL CENTER

PRIORITY - ORGANIZATIONS & CLUBS.

First: Sun City Town Hall Center Corporation meetings and Board of Directors Meetings. Sun City Home Owners meetings.

Second: Sun City Town Hall Center recognized clubs and their committees. Also Sun City Town Hall Center Committees and Sub-Committees.

Third: Sun City Town Hall area non-recognized Clubs.

Fourth: Entertainment events open to all Sun City Town Hall Center members.

Fifth: Sun City Civic, Fraternal and Service Clubs.

These rules are necessary due to the demand for space and so that Town Hall recognized clubs will have priority.

VOTING PROCEDURE

Section 1. A voice or standing vote shall prevail on all matters of business except as follows:

- a. The election of all officers and directors.
- b. Amendments to the By-Laws.
- c. Recall of any officer and/or any member of the Board of Directors.
- d. When a majority of the Board of Directors request a secret ballot.
- e. When a secret ballot is requested by a majority vote of the eligible members of the corporation at a regular meeting.

CENTER LOCATED IN LOUNGE

The Town Hall Center Office is located in the lounge at 10600 Peoria Avenue, Telephone — 933-5281 with one paid office employee, Secy. Helen Foster.

Committees . . .

A section of the By-Laws of Town Hall Center dealing with Standing Committees.

Article VI - Committees

SECTION 1. Only residents of Sun City Units 2, 3, 4, 5 and 6 holding active membership cards shall be eligible to serve on any committee.

SECTION 2. Standing committees shall be appointed by the President with the advice and consent of the Board of Directors.

SECTION 3. The standing committees and their duties shall be as follows:

a. COMMITTEE ON COMMITTEES - To recommend qualified persons to the President for committee membership. It shall consist of not less than seven (7) active members.

b. FINANCE COMMITTEE - To have general control of the finances, subject to the approval of the Board of Directors, including ways and means for obtaining funds necessary to meet the authorized budget for carrying out the work of the corporation.

To present in writing, not later than December 15 of each year, an itemized estimate of the income and expenses for the ensuing year, which upon approval of the Board of Directors shall become the authorized budget for that year, and no obligation beyond the amount thus authorized shall be incurred by any committee or agent of the corporation unless specially authorized by the Board of Directors.

c. HOUSE COMMITTEE - to have general management, subject to the Board of Directors, of the use of the facilities and equipment of Sun City Town Hall Center and adjoining buildings and grounds, except that which is under direct supervision of recognized clubs.

To receive and consider requests from recognized clubs and/or other groups and organizations within and without Units 2, 3, 4, 5 and 6, who desire to use the facilities and equipment; issue permits according to the rules and regulations governing Sun City Town Hall Center; and make available such facilities

Sun City Town Hall Center Facilities Agreement

Excerpts from agreement signed by homeowners who purchased their Sun City property.

I understand that the operation and maintenance of the Town Hall facilities are obligations of Sun City Town Hall Center whose members are the home owners and for whose benefit the said facilities are operated and maintained.

I further understand that the said facilities enhance the value of my property, that they were an inducement to me and other home owners to purchase our homes and also added to the prestige of this retirement center in all parts of the United States and the Americas.

I agree to pay annually in advance to Sun City Town Hall Center the amount of the assessments deemed necessary and determined by the Board of Directors for the operation and maintenance of its Town Hall facilities. The first payment shall be for a period of one year beginning on the date the home owner closes, said payment to go into escrow to the escrow agent, and said escrow agent shall pay said amount to Sun City Town Hall Center upon closing of the escrow. At the end of the first year I agree to make payment of a prorated assessment to the calendar year and thereafter pay annually in advance for each calendar year.

I further agree that, in the event of sale by me of my home, this agreement shall be transferred and assigned to the purchaser and made a part of the transfer of title, obligating the purchaser to pay all further assessments to become due under the terms of this agreement.

and equipment as needed to cover the terms of the permit.

To determine all charges and fees for use of facilities and equipment, collecting same from any group subject to such fees.

To schedule and coordinate all activities and events in which buildings, facilities and equipment of the corporation is involved in and about Sun City Town Hall Center.

To determine, organize, promote and supervise all special entertainment other than that of recognized clubs which will be of interest and benefit to the members of the corporation.

To form such sub-committees as properties, scheduling and special entertainment, determining their duties and functions in order to accomplish the purposes and duties of the committee.

d. SAFETY COMMITTEE - To survey and recommend to the Board of Directors rules and regulations regarding safety precautions and elimination of hazards in the entire Sun City Town Hall Center.

e. CLUB ORGANIZATION COMMITTEE - To receive, review and recommend to the Board of Directors applications that conform to Article VII, sections 1 and 2, for new and/or recognized clubs and to assist in their organization and functions.

To review annually all recognized clubs and to report to the Board of Directors any changes in their program, operation and/or By-Laws.

f. PUBLIC RELATIONS COMMITTEE - To provide information to all residents of Units 2, 3, 4, 5 and 6 concerning the available facilities, activities and purposes of the corporation, through appropriate publicity.

To maintain good public relations between all residents of Sun City.

It shall consist of not less than five (5) active members plus the publicity chairman of each recognized club.

SECTION 4. Special committees may be appointed by the President with the advice and consent of the Board of Directors.

Town Hall Club News

Published In The Interest Of Town Hall Members SUN CITY, ARIZONA

March 1965

PURPOSE

The purpose of this newsletter is to better acquaint Town Hall residents with the available facilities.

The facilities of Town Hall Center are for the use of all persons holding current Town Hall membership cards. Beginners are welcome. Classes may be formed as needed.

CLUB NEWS

ART CLUB. The Art Club recognizes its responsibility to provide instructions for its members. Instructions are available for beginners and advanced students. Lectures or demonstrations are given at the regular business meeting the second Tuesday of the month. Members meet for workshop on the other Tuesdays of the month.

BRIDGE - MIXED. Meets every Thursday at 7:30 p.m. Dues \$1.00 per person per year. A potluck dinner is held in November for all members and their guests.

BRIDGE - LADIES. Meets every Friday at 1:00 p.m. Dues \$1.00 per person per year. Luncheon is held in November for all members.

CAMERA CLUB. Meets every Wednesday at 7:30 p.m. There are instruction programs on how to make better pictures. Members show their slides at some meetings. Field trips are planned frequently.

CERAMICS. A working class with instructions meets every Monday 9:00 a.m. to 3:00 p.m. Pouring classes on Tuesday and Thursday 9:00-12:00 a.m. Free form molding instructions on Wednesdays 9:00 to 12:00 a.m. There will be pouring of stoneware on Fridays beginning in March.

GOREN BRIDGE DEVELOPMENT CLUB. For those who have taken lessons and feel the need of playing experience. Tues. 7:30 p.m.

DANCE CLUB. A group interested in social dancing as a means of recreation, exercise and good fellowship meets on Saturdays at 8:30 p.m. Newcomers are invited to a get-acquainted dance the second Saturday each month.

LADIES GYMNASTICS. A Grand March at 9:30 a.m. on Saturday starts a morning of rhythmic dancing and gymnastics under the able guidance of instructors.

LAPIDARY. A hobby that can be enjoyed by both men and women. Business meeting the first Friday of each month in the Mosaic Room at 1:30 p.m. Lapidary Room is open daily from 8:30 a.m. to 5:00 p.m. Monday through Saturday. Special instruction each Friday at 1:30 p.m.

LAWN BOWLING. A member of the American Lawn Bowls Association. Tournaments are arranged between Town Hall and Community Center. Instructions for beginners is available on Thursdays at 10:00 a.m. on the practice green. Equipment for beginners is furnished by the club.

MEN'S CLUB. Regular monthly meetings on the second Wednesday at 7:00 p.m. Other events of interest such as bridge, golf tournament, outstanding speakers and cultural programs are planned.

ROSE & GARDEN SOCIETY. Meets the second Tuesday of the month at 7:30 p.m. The objective of club is to create more interest in growing flowers and plants to make homes more attractive and Sun City a more beautiful place in which to live. At each meeting some phase of horticulture is covered by an expert. Advice is given on soil preparation and selection of plants best suited to this area. Rose pruning demonstrations in local gardens are held each year. Members have volunteered to prune roses and do the necessary grooming at Town Hall Center.

MOSAIC CLUB. Meets every Friday at 9:00 a.m. This club offers an opportunity to be creative and to enjoy fellowship with people of like interests.

SQUARE DANCE CLUB. Known as the Sun City Twirlers. Meets every Friday. Class for beginners starts at 7:00 p.m. Advanced classes at 8:30 p.m. Members are all enthusiastic dancers and learn fast under the instructions of a capable and efficient caller.

SHUFFLEBOARD. Business meeting first Tuesday each month at 1:00 p.m. Tournament play on Tuesdays and Thursdays. Team match games are held with Community Center Club.

SWIM CLUB. A group who enjoy the pool and who are in charge of making and enforcing rules for the protection of pool users and the facilities. Volunteers from this group donate time to act as monitors. Social events are also planned.

SR. WOMAN'S LEAGUE. Meets the third Thursday each month at 10:00 a.m. A charitable, social and cultural organization.

WOODWORKING. Meets the third Saturday each month at 10:00 a.m. Workshop equipment is available. Those using these facilities are urged to handle equipment with care.

STITCH & KNIT CLUB. Craft classes with instructions in sewing and knitting on Wednesdays at 9:00 a.m. Business meeting first Wed of each month. Classes in Christmas decorating start in September.

* * *

**TOWN HALL FACILITIES AND
PROPERTY BELONG TO TOWN
HALL MEMBERS. EXTREME
CARE AND CAUTION SHOULD
BE PRACTICED IN USING
THESE FACILITIES**

* * *

MONDAY NIGHT AT THE MOVIES

Movies sponsored by the Board of Directors and under the management of Landon Atkins was organized in 1962. Many fine movies are shown. Every Monday night at 7:30 p.m. A minimum contribution of 50c per person is suggested.

* * *

**MEMBERS WHOSE CARDS
EXPIRE DURING 1965
(BLUE CARDS) MAY OBTAIN
THE NEW YELLOW
MEMBERSHIP CARDS
FROM HELEN FOSTER IN
THE SECRETARY'S OFFICE
IN THE LOUNGE**

Town Hall Club News

SUN CITY, ARIZONA

Editor Rill Abrisch

Associate Editor Pauline Box

Associate Editor Forrest Fullerton

RULES FOR ASSIGNING SPACE IN TOWN HALL CENTER

PRIORITY — ORGANIZATIONS & CLUBS

First: Sun City Town Hall Center Corporation meetings and Board of Directors Meetings. Sun City Home Owners meetings.

Second: Sun City Town Hall Center recognized clubs and their committees. Also Sun City Town Hall Center Committees and Sub-Committees.

Third: Sun City Town Hall area non-recognized Clubs.

Fourth: Entertainment events open to all Sun City Town Hall Center members.

Fifth: Sun City Civic, Fraternal and Service Clubs.

These rules are necessary due to the demand for space and so that Town Hall recognized clubs will have priority.

STATEMENT OF PRINCIPLE FOR TOWN HALL CENTER

The Board of Directors of Town Hall Center in the regular monthly meeting of March 2, 1964, approved the "STATEMENT OF PRINCIPLE" as recommended by the House Committee which follows:

The facilities of Town Hall Center are for the use of all persons holding current Town Hall Center Membership cards and their house guests.

Members of Recognized Town Hall Clubs shall not have special advantages over non-club members in the use of Craft Facilities.

For the Safety and Protection of all Town Hall Center members, the Recognized Club shall formulate rules and safety regulations covering the use of tools and/or equipment utiliz-

ed by Club Members and Non-Club Members. (Per By-Law of Sun City Town Hall Center, Article VII, Section 1, paragraph d). All such rules and regulations must be submitted to the CLUB ORGANIZATION COMMITTEE for their approval. Approved rules and regulations must be posted in the area used by the club.

The facilities in the Arts & Crafts Rooms are for hobbies and not for the manufacture of articles to be sold by individuals for private gain.

Recognized clubs may offer for sale, articles made in the Arts & Crafts rooms provided the profit is retained by the club.

Recognized clubs may employ instructors, entertainers, etc., for the benefit of and by the request of its members. Fees, if any, are to be collected by the club.

* A RECOGNIZED CLUB is a group of 25 or more Town Hall residents who have formed a club for a specific purpose. Their by-laws are approved by the Club Organization Committee as being not restrictive to other members of Town Hall.

FIRST YEAR OF OWNERSHIP

This will be our first year of ownership operation. The Board of Directors wants you to know how it will be run, and who will be responsible for the various operations necessary to maintain and operate a \$500,000.00 club.

Members of the Town Hall Center Board of Directors are assigned to be chairmen of the various major committees. HOUSE COMMITTEE has the responsibility to supervise the operating of the facilities. Lan Atkins is chairman. Vern Hamborg, vice-chairman. Supervising the Landscaping, greens, etc., Karl Dimmitt, an Agricultural Engineer. Housekeeping, such as janitor service, etc., responsibility is Edward Jackley's. Supervising building and equipment, repairs and replacement-chairman is James Woodin, former Kansas State Director of Industrial Arts. To set up proper accounting procedure William Gobeille is in charge. He is a former I.B.M. manager and an accounting

specialist. The work of scheduling space to the various clubs is in charge of Leo Yort.

FINANCE COMMITTEE. Taylor Smith, Chairman. Principle objective is to keep a close watch on Town Hall expenses so the property may be maintained at a minimum cost consistent with proper care of grounds and buildings.

CLUB ORGANIZATION COMMITTEE. Edward Austin, Chr. The work of this committee is to study by-laws and functions of all Town Hall Center clubs in order to provide smooth operation and unified privileges for Town Hall Center residents.

LEGAL COMMITTEE. David Gerig, chairman. Legal problems of the board are referred to this committee for guidance and direction.

COMMITTEE ON COMMITTEES. Harvey Spiegel, chairman. This committee investigates people with special talents and refers these names to the president who in turn sets up the committees. Submits names to the Board given to them by each recognized club and from this list the Board selects the nominating committee.

SAFETY COMMITTEE. Earl Holmes, Chairman. To survey and recommend to Board, rules and regulations regarding safety precautions and eliminating hazardous conditions at Town Hall Center.

PUBLIC RELATIONS COMMITTEE. Rill Abrisch, chairman. Through appropriate publicity, this committee provides information to all residents concerning facilities and activities of Town Hall Center. This is accomplished by working with the publicity chairman of each club. Newcomers are welcomed to Sun City by this committee.

* * *

Sun City is blessed with a great deal of talent and that talent is being utilized on every committee.

CENTER LOCATED IN LOUNGE

The Town Hall Center Office is located in the lounge at 10600 Peoria Avenue, Telephone — 933-5281 with one paid office employee, Secy. Helen Foster.

Town Hall Club News

SUN CITY, ARIZONA

Editor Rill Abrisch

Associate Editor Pauline Box

Associate Editor Forrest Fullerton

RULES FOR ASSIGNING SPACE IN TOWN HALL CENTER

PRIORITY — ORGANIZATIONS & CLUBS

First: Sun City Town Hall Center Corporation meetings and Board of Directors Meetings. Sun City Home Owners meetings.

Second: Sun City Town Hall Center recognized clubs and their committees. Also Sun City Town Hall Center Committees and Sub-Committees.

Third: Sun City Town Hall area non-recognized Clubs.

Fourth: Entertainment events open to all Sun City Town Hall Center members.

Fifth: Sun City Civic, Fraternal and Service Clubs.

These rules are necessary due to the demand for space and so that Town Hall recognized clubs will have priority.

STATEMENT OF PRINCIPLE FOR TOWN HALL CENTER

The Board of Directors of Town Hall Center in the regular monthly meeting of March 2, 1964, approved the "STATEMENT OF PRINCIPLE" as recommended by the House Committee which follows:

The facilities of Town Hall Center are for the use of all persons holding current Town Hall Center Membership cards and their house guests.

Members of Recognized Town Hall Clubs shall not have special advantages over non-club members in the use of Craft Facilities.

For the Safety and Protection of all Town Hall Center members, the Recognized Club shall formulate rules and safety regulations covering the use of tools and/or equipment utiliz-

ed by Club Members and Non-Club Members. (Per By-Law of Sun City Town Hall Center, Article VII, Section 1, paragraph d). All such rules and regulations must be submitted to the CLUB ORGANIZATION COMMITTEE for their approval. Approved rules and regulations must be posted in the area used by the club.

The facilities in the Arts & Crafts Rooms are for hobbies and not for the manufacture of articles to be sold by individuals for private gain.

Recognized clubs may offer for sale, articles made in the Arts & Crafts rooms provided the profit is retained by the club.

Recognized clubs may employ instructors, entertainers, etc., for the benefit of and by the request of its members. Fees, if any, are to be collected by the club.

* A RECOGNIZED CLUB is a group of 25 or more Town Hall residents who have formed a club for a specific purpose. Their by-laws are approved by the Club Organization Committee as being not restrictive to other members of Town Hall.

FIRST YEAR OF OWNERSHIP

This will be our first year of ownership operation. The Board of Directors wants you to know how it will be run, and who will be responsible for the various operations necessary to maintain and operate a \$500,000.00 club.

Members of the Town Hall Center Board of Directors are assigned to be chairmen of the various major committees. HOUSE COMMITTEE has the responsibility to supervise the operating of the facilities. Lan Atkins is chairman. Vern Hamborg, vice-chairman. Supervising the Landscaping, greens, etc., Karl Dimmitt, an Agricultural Engineer. Housekeeping, such as janitor service, etc., responsibility is Edward Jackley's. Supervising building and equipment, repairs and replacement-chairman is James Woodin, former Kansas State Director of Industrial Arts. To set up proper accounting procedure William Gobeille is in charge. He is a former I.B.M. manager and an accounting

specialist. The work of scheduling space to the various clubs is in charge of Leo Yort.

FINANCE COMMITTEE. Taylor Smith, Chairman. Principle objective is to keep a close watch on Town Hall expenses so the property may be maintained at a minimum cost consistent with proper care of grounds and buildings.

CLUB ORGANIZATION COMMITTEE. Edward Austin, Chr. The work of this committee is to study by-laws and functions of all Town Hall Center clubs in order to provide smooth operation and unified privileges for Town Hall Center residents.

LEGAL COMMITTEE. David Gerig, chairman. Legal problems of the board are referred to this committee for guidance and direction.

COMMITTEE ON COMMITTEES. Harvey Spiegel, chairman. This committee investigates people with special talents and refers these names to the president who in turn sets up the committees. Submits names to the Board given to them by each recognized club and from this list the Board selects the nominating committee.

SAFETY COMMITTEE. Earl Holmes, Chairman. To survey and recommend to Board, rules and regulations regarding safety precautions and eliminating hazardous conditions at Town Hall Center.

PUBLIC RELATIONS COMMITTEE. Rill Abrisch, chairman. Through appropriate publicity, this committee provides information to all residents concerning facilities and activities of Town Hall Center. This is accomplished by working with the publicity chairman of each club. Newcomers are welcomed to Sun City by this committee.

* * *

Sun City is blessed with a great deal of talent and that talent is being utilized on every committee.

CENTER LOCATED IN LOUNGE

The Town Hall Center Office is located in the lounge at 10600 Peoria Avenue, Telephone — 933-5281 with one paid office employee, Secy. Helen Foster.

OFFICERS OF TOWN HALL CENTER

Pres., Leland D. Cornell	933-0000
J. P., A. Lambert Bergman	2731
Treas., Bertha Roberts	2200
Secy., John E. Davis	2300

DIRECTORS

Ida (Rill) Abrisch	2980
Landon B. Atkins	3560
Edward C. Austin	2578
Arthur Cherry	1868
David H. Gerig	0085
Earl M. Holmes	2990
Taylor Smith	0131

MEMBERSHIP DUES

Now that Town Hall belongs to all the property owners of units in Town Hall area, the maintenance and operational costs of the \$500,000.00 asset to our property becomes yours and mine. Over 80 per cent of our folk have willingly accepted this financial responsibility. If you should be one of the **very few** who have not yet "paid your share" for 1965, won't you be cooperative enough to come to the Secretary's office with your check for \$20.00 per person indicating that you too are proud of our Center, which sets our "Sun City" far above the run-of-mill real estate developments.

LET'S ALL PAY OUR FAIR SHARE!

TOWN HALL NOW BELONGS TO ITS MEMBERS

TO: THE BOARD OF DIRECTORS AND THE GENERAL MEMBERSHIP OF TOWN HALL CENTER, PAST PRESENT AND FUTURE.

It is our very great pleasure to present this folio containing the Official Documents of Title Transfer for the Real Property and Improvements described therein and identified as Town Hall Community Center. This parcel, together with the several score of Recreational Facilities encompassed within its boundaries, is conveyed and entrusted to your perpetual stewardship. It is our sincere wish and prayer, that these facilities will continue to be utilized to their fullest extent as an instrument to promote and further human relations amongst fellow men who are privileged to share the re-

efined period of their lives on a common level here at Sun City.

It is inherent in each of us to desire and seek happiness for ourselves and our loved ones. Complete and true happiness must come from within. The shortest route to happiness is through the warm friendship and associations of others toward whose happiness one had the pleasure of contributing personally.

May God grant that, from this day forward, happiness in Sun City will

flourish and thrive for all those who come and partake of its bounty. Future generations will caress and uphold with pride the traditions of true happiness established and cemented here by the pioneers of this new way of life.

DEL E. WEBB
DEVELOPMENT COMPANY
THE MANAGEMENT

T. P. KOHL
PROJECT MANAGER

To help you get greater enjoyment living in Sun City the Town Hall clubs are interested in helping everyone who has an interest in social and craft activities. To help us organize beginners classes we ask you to please complete the survey below.

SURVEY

My interests are in:	Lady	Man
Shuffleboard
Lawn Bowling
Bridge
Pinochle
500 & Canasta
Horse Shoe
Swimming
Little Theatre
Other:
I am interested in learning:		
Art (Painting)
Sewing
Knitting
Ceramics
Leathercraft
Mosaic
Lapidary
Ballroom Dancing
Square Dancing
Woodworking
Bridge
Other:

Other club activities available: Coin Club, Camera Club, Rose and Garden Club, Ladies Gymnastics, Men's Club and Senior Women's League. Circle club of interest to you and you will be notified of next meeting.

When Kaffee Klatches for the various States of the U. S. are organized, I am interested in attending one for members from the state of.....

NAMES

ADDRESS

PHONE

PLEASE MAIL OR PRESENT TO:
Town Hall Survey
10600 Peoria Avenue
Sun City, Arizona 85351

CLUB DIRECTORY

CLUB	CHAIRMAN	PHONE
Art, Hall N. Abrisch		933-2980
Bridge (Goren), Ruth Olinger		
Bridge (Thurs.), Mr. and Mrs. Chas. O'Brien		4506
Bridge (Fri.), Luanna Behnke		4805
Camera, Walter E. Casey		4455
Ceramics, Teddi Caldwell		4820
Dance, Spencer Parker		3981
Ladies Gym, Mabel Corman		3388
Lapidary, P. E. Fader		4488
Lawn Bowl, George Milne		3814
Men's Club, Chris Nelson		0340
Mosaic, Paula Steinberg		5456
Rose & Garden, Wendell Noell		2634
Sr. Women's Dorothy Campbell		0322
Stitch & Knit, Bertha Cox		2660
Shuffleboard, J. Higginbotham		3864
Square Dance, James Priest		3250
Swim Club, Alex Tinker		4624
Woodworking, Earl Besecker		3714

For further information call above named chairmen.

MAY 10th YOUR
TOWN HALL CORPORATION
MEETING
1:30 p.m. at TOWN HALL
IMPORTANT YOU ATTEND

BE SURE TO COMPLETE
SURVEY. IF YOU HAVE
ANY QUESTIONS PLEASE
CONTACT A CLUB CHAIRMAN
OR CALL HELEN FOSTER
TOWN HALL SECRETARY,

933-5281

Sun City Town Hall Center Facilities Agreement

Excerpts from agreement signed by homeowners who purchased their property from the Del Webb Company in Sun City.

I understand that the operation and maintenance of the Town Hall facilities are obligations of Sun City Town Hall Center whose members are the home owners and for whose benefit the said facilities are operated and maintained.

I further understand that the said facilities enhance the value of my property, that they were an inducement to me and other home owners to purchase our homes and also added to the prestige of this retirement center in all parts of the United States and the Americas.

I agree to pay annually in advance to Sun City Town Hall Center the amount of the assessments deemed necessary and determined by the Board of Directors for the operation and maintenance of its Town Hall facilities. The first payment shall be for a period of one year beginning on the date the home owner closes, said payment to go into escrow to the escrow agent, and said escrow agent shall pay said amount to Sun City Town Hall Center upon closing of the escrow. At the end of the first year I agree to make payment of a prorated assessment to the end of the calendar year and thereafter pay annually in advance for each calendar year.

I further agree that, in the event of sale by me of my home, this agreement shall be transferred and assigned to the purchaser and made a part of the transfer of title, obligating the purchaser to pay all further assessments to become due under the terms of this agreement.

OPEN HOUSE

ALL RESIDENTS OF TOWN HALL CENTER
AREA ARE INVITED TO ATTEND AN OPEN
HOUSE AT THE NEW BUILDING AT THE CENTER
AFTER THE CORPORATION MEETING
ON:

MONDAY, MAY 10, 1965

HAWAIIAN LUAU

1965

TOWN HALL CENTER OCT. 18th

Three and one half hours of
FUN FOOD FROLIC

**CELEBRATING THE START OF THE
TOWN HALL CENTER SOCIAL SEASON
FOR 1965 - 66**



5:30 P.M. SOCIAL HOUR: Meeting New and Old Friends around the Hawaiian Punch Bowls and watching the KANE-WAHINE DANCERS PERFORMING UNDER THE PALM TREES.

6:30 P.M. DINING: Twenty Five Beautiful Wahines to serve you Delicious Food in Charming surroundings.

7:45 P.M. ENTERTAINMENT: The Minehune Troupe of Polynesian Dancers performing Island Dances to the tune of Hawaiian guitars. See the fascinating FIRE DANCE. Listen to the beautiful songs.

to

9:00 P.M.

TICKETS:

Admission is by ticket only. Due to limited space the tickets are restricted to only 600 active members of Town Hall Center and their House Guests. First Come -- First Served (Tickets).

CONTRIBUTION

\$2.00 per Person

Get your tickets from any Town Crier Club Member (see list) or from the Chairmen of all Town Hall Clubs.

**LETS MAKE A DATE FOR OCTOBER 18TH, HAWAIIAN LUAU
WEAR YOUR MUMU, LAVA LAVA, HAWAIIAN SHIRT
TOWN CRIERS CLUB MEMBERS**

FORREST FULLERTON, Capt.
10301 Audrey Ave.
NELSON CORNER
10363 Audrey Ave.
BOB RAMAGE
10613 Clair Dr.
GLENN WILSON
10419 Deanne Dr.
ROYAL HANDY
10638 Camden Ave.
WILLIAM CHAPMAN
10602 Cumberland Ave.
EARL DANIELS, Capt.
11226 109th Ave.
GROVER ADAMS
10815 110th Ave.
CHARLES DAWSON
10809 Madison Dr.
HELEN DeJARNETTE
11223 110th Dr.
FRED FEEKIN
10728 Abbott Ave.
LEO YORT
10911 Abbott Ave.
E. JACK JACKLEY, Capt.
10615 102nd Dr.
JOE HARTIGAN
10150 Pinehurst Dr.
EARL BOB ROBISON
10247 N. Snead Circle
HAROLD TERHUNE
10629 103rd Ave.

HENRY JACOBS, Capt.
10028 Peoria Ave.
VERNE HAMBORG
10007 Lakeview Circle
JERRY TURNER
9925 La Jolla Circle North
HAROLD LYONS
9940 Peoria Ave.
EARL HOLMES, Capt.
10135 Desert Hills Dr.
LEONARD DEMARS
10020 Riviera Dr.
LES BEHNKE
10026 Riviera Dr.
WILLIAM FRINSLOO
10031 Desert Hills Dr.
THOMAS JENNINGS
10230 Desert Hills Dr.
DELBERT SCRUBY
9949 Alabama Ave.
HAROLD RISSLER
10219 Alabama
ART EVANS
11423 103rd Ave.
R. C. RIDDELL
10113 Desert Hills Dr.
EDWARD AUSTIN, Capt.
10747 Hope Dr.
FLOYD BAKER
10741 Hope Dr.
GEO. & CHRISTINA MILNE
11202 105th Ave.

MILLARD BRICKER
10765 Hope Dr.
WENDELL NOELL
10750 Crosby Dr.
HENRY PAINTER
10738 Crosby Dr.
ALBERT KAMPSCHROER
10725 El Dorado Dr.
EARL EMMERSON
10802 El Dorado Dr.
JOE FAVRE
10713 El Dorado Dr.
MARGARET COOK
11409 109th Ave.
LEWIS BROWN
11418 109th Ave.
SARAH NELSON, Capt.
11032 Sun City Blvd.
MARGARET & DUDLEY DIGGS
10854 Canterbury Dr.
LOUIS SNELL & HELEN SNELL
11022 Connecticut Dr.
HELEN CURTIS
11007 Elk Ave.
CHARLES FRENCH
11033 Elk Ave.
GLENN PARK, Capt.
10430 Snead Dr.
HARVEY SPIEGEL
10436 Snead Dr.
C. M. SAGMOEN
10325 Monterosa Dr.

GERALD CARRIER
10613 Hope Dr.
SCOT COULTER
10337 Snead Dr.
ORVILLE ESHER
10608 Crosby Dr.
FLOYD GARROW
10531 La Jolla Dr.
VIRGIL WILLIAMS, Capt.
10046 Sun City Blvd.
DEWEY THOMAS
10101 Sun City Blvd.
ANSEL BROOKS
10229 Sun City Blvd.
F. HUGH KELLEY
11401 Coggins Dr.
FRANK SPRINGER
10124 Palmer Dr.
E. T. WELLS
10109 Pebble Beach Dr.
FRED SHELEDY, Capt.
10848 Fairway Court East
ARTHUR HECKLER, Capt.
10847 Fairway Court West
LAIRD FRYER, Capt.
11453 Balboa Dr.
DONALD SCOTT
11838 Mission Dr.
JOE FARQUHAR
11445 Balboa Dr.

PUBLIC RELATIONS COMMITTEE

RILL ABRISCH, Chairman
10213 Inwood Court
ART CHERRY, Co-chairman
10002 Palmer Dr.

MARGARET COOK, LUAU CHAIRMAN
11409 109th Ave. - Phone 933-3739

PAULINE BOX
10032 Desert Hills Dr.
HELEN MASSEY
10233 Pinehurst Dr.

ART MATHIS, TICKET CHAIRMAN
10151 Sun City Blvd. - Phone 933-3150

JAMES VANNEMAN
10702 El Dorado Dr.
FORREST FULLERTON
10301 Audrey Ave.

**Due to Popular Demand
A Repeat Performance to
be held Oct. 18th
Give your nearest Town
Crier Member the tickets
Oct. 18 show sold out in 3 days**